

ADDENDUM NO. 3

Date: February 12, 2025

Project Name: Apiculture Facility

Project No.: 132

SCO ID: 22-24494-01A Code: 42124 Item: 315

NCSU: 202220007

The following clarifications, amendments, additions, deletions, revisions, and modifications are hereby made a part of the Contract Documents and change the original documents only in the manner and to the extent stated below.

BIDDING QUESTIONS AND RESPONSES

1. **Question:** *“Could detail 11/L7.20 for the wood privacy fence, be verified as a part of the GC’s scope of work and to be included in the base bid?”*

Response: Yes, the fence is to be 6’ min. ht. wood opaque fence. Submit shop drawings for approval prior to installation.

2. **Question:** *“When does NC State plan to perform the landscaping scope of work? Overlap with the 240-day construction time would limit lay down space depending on when the landscaping scope would start.”*

Response: We do not expect landscaping work to begin until Spring 2026. However, should the Owner’s work overlap with the construction, NC State will coordinate with the GC to avoid lay-down space dedicated to the building.

3. **Question:** *“Could you verify that the 6 observation hive bases, that are being surrounded by PPM-2, are to be constructed from a CFMF structure? If so, please confirm that this would be more of a delegated design as there are no details pertaining to the structure shown on 4/A703?”*

Response: Correct, we expect these hive bases to be included in the delegated design package specified in 05 4000 “Cold-Formed Metal Framing.”

4. **Question:** *“Do we only have boxes and conduit rough in for security system?”*

Response: The EC shall only provide raceway, boxes, and cover plates for the security system. The Owner shall provide the security system devices and wiring.

5. **Question:** “Are we installing main data conduit feeds from the MDF room to outside building footprint and others continue conduits to Inwood road?”

Response: Contractor shall provide conduit in duct bank to a handhole at the Inwood road right-of-way. The Owner will provide extensions to the intersection of Inwood Road and Dairy Lane.

6. **Question:** “Are both docking stations (SB- 400 amp, LS- 100 amp) in the base bid or is the 400 amp docking station the only one in the base bid?”

Response: “The optional standby 400A docking station is included in the base bid. The life safety 100A docking station is included as part of the alternate.”

7. **Question:** “Also need to know parking lot light pole type and height. E101 note I just describes the pole light fixture. No info on pole or height.”

Response: Refer to Addendum No. 2. The pole basis of design and height was provided.

8. **Question:** “Plans say the water well is by the owner. Does that include the well pump, piping and wiring inside the well? If so, who provides wiring from well to the building? It looks like we connect at the top of the well?”

Response: NCSU has contracted separately for the construction of the well pump and piping. Contractor to connect to well stub out. Wiring from the well to the building to be by electrical contractor.

9. **Question:** “Has there been a permit issued by the Health Department for the new Septic System shown on the drawings? Will the Health Department permit be a requirement of our Septic System subcontractor?”

Response: The permit has been applied for, but the selected contractor will need to have the proposed building corners and property corners / property lines flagged or staked in the field. Once completed, the Contractor will need to notify the AHJ that the site is ready for evaluation.

10. **Question:** “I saw the response in Addendum #2 of keeping the 240 day schedule even with lead time and maybe adjusting that once a GC is awarded. However, our structural guys have suggested a design change that could definitely help with procurement to stay on that timeline. The driver are the joists and they have suggested ILO of the joist, erect beams instead (conservative W16x26) and we could save about a month of procurement time with cost staying relatively the same. Could this be a potential design alternate?”

Response: NC State wishes to execute this project within the duration of construction identified in the specs. However, we will work with the selected GC and the NTP can be adjusted to accommodate the procurement of long-lead time items. For bidding purposes, no modifications to the structural system will be considered.

11. **Question:** “Existing Septic Tank - can we use fill? Verify notes on drawings are correct and comply with Wake County?”

Response: Refer to revised Specification Sections 01 2100 “Allowances,” 01 2200 “Unit Prices,” and 01 2300 “Alternates.”

12. **Question:** *“The drawings only call for fill for the basement and the septic, should there be seed to stabilize the area?”*

Response: Temporary seed to be applied to disturbed areas to meet erosion control requirements.

13. **Question:** *“Could a basis of design or any product detail/spec section be supplied for the screen system with the aluminum frame shown on 2/A404 surrounding the "Education Hive" location?”*

Response: Refer to Revised Sheets A252, A253, and A404 and revised Specification Section 08 41 13 “Aluminum-Framed Entrances and Storefronts”

14. **Question:** *The door schedule indicates that 115.1 is an aluminum storefront door, but the head and jamb details show a HM frame.”*

Response: Refer to revised Sheet A251.

15. **Question:** *“The door schedule indicates that Door 106.2 is a hollow metal door with an aluminum frame. Is this correct?”*

Response: Refer to revised Sheet A251.

16. **Question:** *“The storefront elevations on sheet A252 indicate that interior frame SF-10 is to have insulated glass. Is this correct?”*

Response: Refer to revised Sheet A251.

17. **Question:** *“The aluminum framed screens would not be in the storefront supplier scope of work, correct?”*

Response: Refer to Revised Sheets A252, A253, and A404 and revised Specification Section 08 41 13 “Aluminum-Framed Entrances and Storefronts.” The screens and frames shall be provided by the storefront supplier.

18. **Question:** *“Is this project open to any GC I heard it was prequalified but wanted to check?”*

Response: This project is open to Pre-Qualified General Contractors only.

19. **Question:** *“Do the existing magnolias and crepe myrtles at the existing house need tree protection?”*

Response: Yes, tree protection at the house to be included in the Alternate No. 10 price.

20. **Question:** *“Will the beehives remain at the existing house if the alternate is accepted?”*

Response: No, the Owner will remove the hives if the Alternate is accepted.”

21. **Question:** *“Will the contractor be responsible for any damage to the existing road going to the demoed house?”*

Response: Yes.

22. **Question:** “Do we need to demolish the transformer on the pole at the house to be demoed?”

Response: Yes. Based on available information, no power is being supplied to the transformer. Contractor to verify.

23. **Question:** “Is water available at the demoed house?”

Response: Yes, the Owner can provide well water.

24. **Question:** “What about the gas tanks at the demoed house?”

Response: Bidders shall assume removal of the tanks. The Owner will drain them.

SUBSTITUTION REQUESTS

1. Section: 08 3513.13 – “Multipanel Folding Aluminum-Framed Glass Doors.”

Manufacturer: TILUTEX LLC, Exclusive Partnership with SUNFLEX-Wall-Systems LP

Disposition: Approved.

2. Section: 07 4113.16 – “Standing-Seam Metal Roof Panels”
07 4213.13 – “Formed Metal Wall Panels”
07 4293 – “Soffit Panels”

Manufacturer: Dimensional Metals, Inc.

Disposition: Approved.

SPECIFICATIONS (attached)

Form of Proposal
012100 – ALLOWANCES
012200 - UNIT PRICES
012300 - ALTERNATES
07 4113.16 – “STANDING-SEAM METAL ROOF PANELS”
07 4293 – “SOFFIT PANELS”
084113 - ALUMINUM-FRAMED ENTRANCES AND STOREFRONTS
230923 FL - DIRECT DIGITAL CONTROL (DDC) SYSTEM FOR HVAC

DRAWINGS (attached)

A101
A251
A252
A253
A404
A705

-- END OF ADDENDUM NO. 3 --

SECTION 012100 - ALLOWANCES

PART 1 - GENERAL

1.1 SUMMARY

- A. Section includes administrative and procedural requirements governing allowances.
- B. Types of allowances include the following:
 - 1. Quantity allowances.
- C. Related Requirements:
 - 1. Section 012200 "Unit Prices" for procedures for using unit prices, including adjustment of quantity allowances when applicable.

1.2 ACTION SUBMITTALS

- A. Submit proposals for purchase of products or systems included in allowances in the form specified for Change Orders.

1.3 INFORMATIONAL SUBMITTALS

- A. Submit invoices or delivery slips to show actual quantities of materials delivered to the site for use in fulfillment of each allowance.
- B. Submit time sheets and other documentation to show labor time and cost for installation of allowance items that include installation as part of the allowance.

1.4 QUANTITY ALLOWANCES

- A. Unless otherwise indicated, Contractor's costs for receiving and handling at Project site, labor, installation, overhead and profit, and similar costs related to products and materials ordered by Owner or selected by Architect under allowance shall be included as part of the Contract Sum and not part of the allowance.

1.5 ADJUSTMENT OF ALLOWANCES

- A. Allowance Adjustment: To adjust allowance amounts, prepare a Change Order proposal based on the difference between purchase amount and the allowance, multiplied by final measurement of work-in-place where applicable. If applicable, include reasonable allowances for cutting losses, tolerances, mixing wastes, normal product imperfections, and similar margins.

1. Include installation costs in purchase amount only where indicated as part of the allowance.
 2. If requested, prepare explanation and documentation to substantiate distribution of overhead costs and other markups.
 3. Submit substantiation of a change in scope of Work, if any, claimed in Change Orders related to unit-cost allowances.
 4. Owner reserves the right to establish the quantity of work-in-place by independent quantity survey, measure, or count.
- B. Submit claims for increased costs because of a change in scope or nature of the allowance described in the Contract Documents, whether for the purchase order amount or Contractor's handling, labor, installation, overhead, and profit.
1. Do not include Contractor's or subcontractor's indirect expense in the Change Order cost amount unless it is clearly shown that the nature or extent of Work has changed from what could have been foreseen from information in the Contract Documents.
 2. No change to Contractor's indirect expense is permitted for selection of higher- or lower-priced materials or systems of the same scope and nature as originally indicated.

PART 2 - PRODUCTS (Not Used)

PART 3 - EXECUTION

3.1 EXAMINATION

- A. Examine products covered by an allowance promptly on delivery for damage or defects. Return damaged or defective products to manufacturer for replacement.

3.2 PREPARATION

- A. Coordinate materials and their installation for each allowance with related materials and installations to ensure that each allowance item is completely integrated and interfaced with related work.

3.3 SCHEDULE OF ALLOWANCES

- A. Allowance No. 1: Quantity Allowance: Include 100 cu. yd. of unsatisfactory soil excavation and disposal off-site and replacement with satisfactory soil material from off-site, as specified in Section 312000 "Earth Moving."
1. Coordinate quantity allowance adjustment with unit-price requirements in Section 012200 "Unit Prices."

- B. *Allowance No. 2: Quantity Allowance: Include 9 tons of placement of #57 stone in the existing septic tank of the home to be demolished. This allowance shall be included in Alternate No. 10.**
- 1. Coordinate quantity allowance adjustment with unit-price requirements in Section 012200 "Unit Prices."**
- C. *Allowance No. 3: Quantity Allowance: Include 150 cubic yards of placement of fill soil to be used at the basement of the home to be demolished. This allowance shall be included in Alternate No. 10.**
- 1. Coordinate quantity allowance adjustment with unit-price requirements in Section 012200 "Unit Prices."**

END OF SECTION

SECTION 012200 - UNIT PRICES

PART 1 - GENERAL

1.1 SUMMARY

- A. Section includes administrative and procedural requirements for unit prices.
- B. Related Requirements:
 - 1. Section 012100 "Allowances" for procedures for using unit prices to adjust quantity allowances.

1.2 DEFINITIONS

- A. Unit price is an amount incorporated into the Agreement, applicable during the duration of the Work as a price per unit of measurement for materials, equipment, or services, or a portion of the Work, added to or deducted from the Contract Sum by appropriate modification, if the scope of Work or estimated quantities of Work required by the Contract Documents are increased or decreased.

1.3 PROCEDURES

- A. Unit prices include all necessary material, plus cost for delivery, installation, insurance, applicable taxes, overhead, and profit.
- B. Measurement and Payment: See individual Specification Sections for work that requires establishment of unit prices. Methods of measurement and payment for unit prices are specified in those Sections.
- C. Owner reserves the right to reject Contractor's measurement of work-in-place that involves use of established unit prices and to have this work measured, at Owner's expense, by an independent surveyor acceptable to Contractor.
- D. List of Unit Prices: A schedule of unit prices is included in Part 3. Specification Sections referenced in the schedule contain requirements for materials described under each unit price.

PART 2 - PRODUCTS (Not Used)

PART 3 - EXECUTION

3.1 SCHEDULE OF UNIT PRICES

- A. Unit Price No. 1: Removal of unsatisfactory soil and replacement with satisfactory soil material.
1. Description: Unsatisfactory soil excavation and disposal off-site and replacement with satisfactory fill material or engineered fill from off-site, as required, in accordance with Section 312000 "Earth Moving."
 2. Unit of Measurement: One cubic yard of soil excavated, based on in-place surveys of volume before and after removal.
 3. Quantity Allowance: Coordinate unit price with allowance adjustment requirements in Section 012100 "Allowances."
 - 4.
- B. ***Unit Price No. 2: Placement of #57 stone in the existing septic tank.**
1. **Description: Placement of #57 stone in the existing septic tank at the house to be demolished.**
 2. **Unit of Measurement: One ton of #57 stone placed.**
 3. **Quantity Allowance: Coordinate unit price with allowance adjustment requirements in Section 012100 "Allowances."**
- C. ***Unit Price No. 3: Placement of fill soil in the existing basement.**
1. **Description: Placement of fill soil in the existing basement at the house to be demolished.**
 2. **Unit of Measurement: One cubic yard of soil placed.**
 3. **Quantity Allowance: Coordinate unit price with allowance adjustment requirements in Section 012100 "Allowances."**

END OF SECTION

SECTION 012300 - ALTERNATES

PART 1 - GENERAL

1.1 SUMMARY

- A. Section includes administrative and procedural requirements for alternates.

1.2 DEFINITIONS

- A. Alternate: An amount proposed by bidders and stated on the Bid Form for certain work defined in the bidding requirements that may be added to or deducted from the base bid amount if the Owner decides to accept a corresponding change either in the amount of construction to be completed or in the products, materials, equipment, systems, or installation methods described in the Contract Documents.
 - 1. Alternates described in this Section are part of the Work only if enumerated in the Agreement.
 - 2. The cost or credit for each alternate is the net addition to or deduction from the Contract Sum to incorporate alternates into the Work. No other adjustments are made to the Contract Sum.

1.3 PROCEDURES

- A. Coordination: Revise or adjust affected adjacent work as necessary to completely integrate work of the alternate into Project.
 - 1. Include as part of each alternate, miscellaneous devices, accessory objects, and similar items incidental to or required for a complete installation whether or not indicated as part of alternate.
- B. Execute accepted alternates under the same conditions as other work of the Contract.
- C. Schedule: A schedule of alternates is included at the end of this Section. Specification Sections referenced in schedule contain requirements for materials necessary to achieve the work described under each alternate.

PART 2 - PRODUCTS (Not Used)

PART 3 - EXECUTION

3.1 SCHEDULE OF ALTERNATES

- A. Alternate No. 1A: Owner Preferred Door Hardware.

1. Base Bid: Provide door hardware by any of the manufacturers listed as specified in Section 08 7100 "Door Hardware."
 2. Alternate: Provide door hardware by the specific manufacturers listed in the "Door Hardware Schedule" as specified in Section 08 7100 "Door Hardware."
- B. Alternate No. 1B: Owner Preferred Brand Controller.
1. Base Bid: Provide controller by any of the manufacturers listed.
 2. Alternate: Provide 300TLF Controller by Digital Security Controls.
- C. Alternate No. 1C: Owner Preferred Controls.
1. Base Bid: Provide controls by any of the manufacturers listed.
 2. Alternate: Provide Controls by Johnson Controls, Inc.
- D. Alternate No. 1D: Owner Preferred Controls.
1. Base Bid: Provide controls by any of the manufacturers listed.
 2. Alternate: Provide Controls by Schneider Electric.
- E. Alternate No. 2: Barnquilt Custom Panels.
1. Base Bid: Omit barnquilt panels as indicated on the Drawings.
 2. Alternate: Provide barnquilt panels as indicated on the Drawings and as Specified in 10 1423 "Panel Signage."
- F. Alternate No. 3: Moveable Glass Wall.
1. Base Bid: Omit moveable glass wall as indicated on the Drawings. Provide metal framed gypsum wall and doors as indicated for base bid.
 2. Alternate: Provide moveable glass wall as indicated on the Drawings.
- G. Alternate No. 4: Ceramic Wall Tile.
1. Base Bid: Omit ceramic wall tile where indicated on the Drawings. Provide high-performance coatings as indicated for base bid.
 2. Alternate: Provide ceramic wall tile as indicated on the Drawings.
- H. Alternate No. 5: Toilet Room 107C.
1. Base Bid: Omit ceramic tile finishes and plumbing fixtures in Room 107C as indicated on the Drawings.
 2. Alternate: Provide fully complete Toilet Room 107C as indicated on the Drawings.
- I. Alternate No. 6: Emergency Generator.
1. Base Bid: Omit emergency generator and equipment as indicated on the Drawings. Generator docking station is base bid.
 2. Alternate: Provide emergency generator as indicated on the Drawings and as specified in Section 26 3214 "Engine Generators."

- J. Alternate No. 7: Polished Concrete.
1. Base Bid: Omit concrete polishing. Provide concrete finish as indicated on the Structural Drawings and as Specified in 03 3000 "Cast-In-Place Concrete."
 2. Alternate: Polish concrete as indicated on the Drawings and as specified in Section 03 3543 "Polished Concrete Finishing."
- K. Alternate No. 8: FRP and PVC Roll Flooring.
1. Base Bid: Omit FRP and PVC roll flooring where indicated on the Drawings as part of the Alternate.
 2. Alternate: Provide FRP and resinous flooring where indicated on the Drawings as being provided as part of the alternate.
- L. Alternate No. 9: AHU Screening.
1. Base Bid: Omit AHU Screening as indicated on the Drawings.
 2. Alternate: Provide AHU screening where indicated on the Drawings as being provided as part of the alternate.
- M. Alternate No. 10: Existing House and Septic Demolition
1. Base Bid: Omit demolition of the existing house, partial basement infill, and septic decommissioning.
 2. Alternate: Perform asbestos abatement per the report, demolish existing house, infill the partial basement, and decommission existing septic system, ***and remove existing transformer** as indicated on the Civil Drawings. ***Allowance Nos. 2 and 3 shall be included in this Alternate.**
- N. Alternate No. 11: Laboratory Casework.
1. Base Bid: Omit Laboratory Casework in Room 104. Utilities shall be capped at the nearest ceiling or wall for ease of future installation.
 2. Alternate: Provide laboratory casework and all utility connections as indicated on the Drawings and as specified in Section 12 3553.13 "Metal Laboratory Casework."

END OF SECTION

SECTION 074113.16 - STANDING-SEAM METAL ROOF PANELS

PART 1 - GENERAL

1.1 SUMMARY

A. Section Includes:

1. Standing-seam metal roof panels.

1.2 PREINSTALLATION MEETINGS

- A. Preinstallation Conference: Conduct conference at Project site.

1.3 ACTION SUBMITTALS

- A. Product Data: For each type of product.

B. Sustainable Design Submittals:

1. Product Data: For recycled content, indicating postconsumer and preconsumer recycled content and cost.

- C. Shop Drawings: Include fabrication and installation layouts of metal panels; details of edge conditions, joints, panel profiles, corners, anchorages, attachment system, trim, flashings, closures, and accessories; and special details.

- D. Samples: For each type of metal panel and each color indicated.

1.4 INFORMATIONAL SUBMITTALS

- A. Product test reports.

- B. Warranties: Sample of special warranties.

1.5 CLOSEOUT SUBMITTALS

- A. Maintenance data.

1.6 QUALITY ASSURANCE

- A. Installer Qualifications: An entity that employs installers and supervisors who are trained and approved by manufacturer.

- B. UL-Certified, Portable Roll-Forming Equipment: UL-certified, portable roll-forming equipment capable of producing metal panels warranted by manufacturer to be the same as factory-formed products. Maintain UL certification of portable roll-forming equipment for duration of work.

1.7 WARRANTY

- A. Special Warranty: Installer's standard form in which installer agrees to repair or replace components of metal panel systems that fail in workmanship within specified warranty period.
 - 1. Warranty Period: Five years from date of Final Completion.
- B. Special Warranty on Panel Finishes: Manufacturer's standard form in which manufacturer agrees to repair finish or replace metal panels that show evidence of deterioration of factory-applied finishes within specified warranty period.
 - 1. Finish Warranty Period: 20 years from date of Final Completion.
- C. Special Weathertightness Warranty: Manufacturer's standard form in which manufacturer agrees to repair or replace standing-seam metal roof panel assemblies that fail to remain weathertight, including leaks, within specified warranty period.
 - 1. Warranty Period: 20 years from date of Final Completion.

PART 2 - PRODUCTS

2.1 PERFORMANCE REQUIREMENTS

- A. Recycled Content: Postconsumer recycled content plus one-half of preconsumer recycled content not less than 25 percent.
- B. Structural Performance: Provide metal panel systems capable of withstanding the effects of the following loads, based on testing according to ASTM E1592:
 - 1. Wind Loads: As indicated on Drawings.
 - 2. Other Design Loads: As indicated on Drawings.
 - 3. Deflection Limits: For wind loads, no greater than 1/240 of the span.
- C. Air Infiltration: Air leakage of not more than 0.06 cfm/sq. ft. when tested according to ASTM E1680 at the following test-pressure difference:
 - 1. Test-Pressure Difference: 6.24 lbf/sq. ft..
- D. Water Penetration under Static Pressure: No water penetration when tested according to ASTM E1646 at the following test-pressure difference:
 - 1. Test-Pressure Difference: 6.24 lbf/sq. ft..

- E. Hydrostatic-Head Resistance: No water penetration when tested according to ASTM E2140.
- F. Wind-Uplift Resistance: Provide metal roof panel assemblies that comply with UL 580 for wind-uplift-resistance class indicated.
 - 1. Uplift Rating: UL 60.
- G. Thermal Movements: Allow for thermal movements from ambient and surface temperature changes by preventing buckling, opening of joints, overstressing of components, failure of joint sealants, failure of connections, and other detrimental effects. Base calculations on surface temperatures of materials due to both solar heat gain and nighttime-sky heat loss.
 - 1. Temperature Change (Range): 120 deg F, ambient; 180 deg F, material surfaces.

2.2 STANDING-SEAM METAL ROOF PANELS

- A. Provide factory-formed metal roof panels designed to be installed by lapping and interconnecting raised side edges of adjacent panels with joint type indicated and mechanically attaching panels to supports using concealed clips in side laps. Include clips, cleats, pressure plates, and accessories required for weathertight installation.
 - 1. Steel Panel Systems: Unless more stringent requirements are indicated, comply with ASTM E1514.
- B. Vertical-Rib, Seamed-Joint, Standing-Seam Metal Roof Panels : Formed with vertical ribs at panel edges and intermediate stiffening ribs symmetrically spaced between ribs; designed for sequential installation by mechanically attaching panels to supports using concealed clips located under one side of panels, engaging opposite edge of adjacent panels, and mechanically seaming panels together.
 - 1. Manufacturers: Subject to compliance with requirements, provide products by one of the following:
 - a. CENTRIA, a Nucor Brand.
 - b. ~~Firestone Building Products~~. Elevate
 - c. Metal Roofing Systems, Inc.
 - d. PAC-CLAD; Petersen Aluminum Corporation; a Carlisle company.
 - 2. Metallic-Coated Steel Sheet: Zinc-coated (galvanized) steel sheet complying with ASTM A653/A653M, G90 coating designation, or aluminum-zinc alloy-coated steel sheet complying with ASTM A792/A792M, Class AZ50 coating designation; structural quality. Prepainted by the coil-coating process to comply with ASTM A755/A755M.
 - a. Nominal Thickness: 24 gauge.
 - b. Exterior Finish: Two-coat fluoropolymer.
 - c. Color: As indicated by manufacturer's designations.

3. Clips: One-piece fixed to accommodate thermal movement.
4. Material:
 - a. 0.028-inch- nominal thickness, zinc-coated (galvanized) or aluminum-zinc alloy-coated steel sheet.
5. Joint Type: Double folded.
6. Panel Coverage: 18 inches.
7. Panel Height: 1.5 inches.

2.3 UNDERLAYMENT MATERIALS

- A. Self-Adhering, High-Temperature Underlayment: Provide self-adhering, cold-applied, sheet underlayment, a minimum of 30 mils thick, consisting of slip-resistant, polyethylene-film top surface laminated to a layer of butyl or SBS-modified asphalt adhesive, with release-paper backing. Provide primer when recommended by underlayment manufacturer.
 1. Thermal Stability: Stable after testing at 240 deg F; ASTM D1970.
 2. Low-Temperature Flexibility: Passes after testing at minus 20 deg F; ASTM D1970.
 3. Manufacturers: Subject to compliance with requirements, provide products by one of the following:
 - a. ATAS International, Inc.
 - b. Carlisle WIP Products; a brand of Carlisle Construction Materials.
 - c. GCP Applied Technologies Inc.
 - d. Henry Company.
 - e. Owens Corning.
- B. Slip Sheet: Manufacturer's recommended slip sheet, of type required for application.

2.4 MISCELLANEOUS MATERIALS

- A. Miscellaneous Metal Subframing and Furring: ASTM C645; cold-formed, metallic-coated steel sheet, ASTM A653/A653M, G90 hot-dip galvanized coating designation or ASTM A792/A792M, Class AZ50 coating designation unless otherwise indicated. Provide manufacturer's standard sections as required for support and alignment of metal panel system.
- B. Panel Accessories: Provide components required for a complete, weathertight panel system including trim, copings, fasciae, mullions, sills, corner units, clips, flashings, sealants, gaskets, fillers, closure strips, and similar items. Match material and finish of metal panels unless otherwise indicated.
 1. Closures: Provide closures at eaves and ridges, fabricated of same metal as metal panels.
 2. Backing Plates: Provide metal backing plates at panel end splices, fabricated from material recommended by manufacturer.

3. Closure Strips: Closed-cell, expanded, cellular, rubber or crosslinked, polyolefin-foam or closed-cell laminated polyethylene; minimum 1-inch- thick, flexible closure strips; cut or premolded to match metal panel profile. Provide closure strips where indicated or necessary to ensure weathertight construction.
- C. Flashing and Trim: Provide flashing and trim formed from same material as metal panels as required to seal against weather and to provide finished appearance. Locations include, but are not limited to, eaves, rakes, corners, bases, framed openings, ridges, fasciae, and fillers. Finish flashing and trim with same finish system as adjacent metal panels.
- D. Gutters and Downspouts: Formed from same material as roof panels according to SMACNA's "Architectural Sheet Metal Manual." Finish to match metal roof panels.
- E. Panel Fasteners: Self-tapping screws designed to withstand design loads.
- F. Panel Sealants: Provide sealant type recommended by manufacturer that are compatible with panel materials, are nonstaining, and do not damage panel finish.
 1. Butyl-Rubber-Based, Solvent-Release Sealant: ASTM C1311.

2.5 FABRICATION

- A. Fabricate and finish metal panels and accessories at the factory, by manufacturer's standard procedures and processes, as necessary to fulfill indicated performance requirements demonstrated by laboratory testing. Comply with indicated profiles and with dimensional and structural requirements.
- B. On-Site Fabrication: Subject to compliance with requirements of this Section, metal panels may be fabricated on-site using UL-certified, portable roll-forming equipment if panels are of same profile and warranted by manufacturer to be equal to factory-formed panels. Fabricate according to equipment manufacturer's written instructions and to comply with details shown.
- C. Provide panel profile, including major ribs and intermediate stiffening ribs, if any, for full length of panel.
- D. Fabricate metal panel joints with factory-installed captive gaskets or separator strips that provide a weathertight seal and prevent metal-to-metal contact, and that minimize noise from movements.
- E. Sheet Metal Flashing and Trim: Fabricate flashing and trim to comply with manufacturer's recommendations and recommendations in SMACNA's "Architectural Sheet Metal Manual" that apply to design, dimensions, metal, and other characteristics of item indicated.

2.6 FINISHES

- A. Panels and Accessories:

1. Two-Coat Fluoropolymer: AAMA 621. Fluoropolymer finish containing not less than 70 percent polyvinylidene fluoride (PVDF) resin by weight in color coat.
2. Concealed Finish: White or light-colored acrylic or polyester backer finish.

PART 3 - EXECUTION

3.1 PREPARATION

- A. Miscellaneous Supports: Install subframing, furring, and other miscellaneous panel support members and anchorages according to ASTM C754 and metal panel manufacturer's written recommendations.

3.2 INSTALLATION OF UNDERLAYMENT

- A. Self-Adhering Sheet Underlayment: Apply primer if required by manufacturer. Comply with temperature restrictions of underlayment manufacturer for installation. Apply at locations indicated on Drawings, wrinkle free, in shingle fashion to shed water, and with end laps of not less than 6 inches staggered 24 inches between courses. Overlap side edges not less than 3-1/2 inches. Roll laps with roller. Cover underlayment within 14 days.
 1. Apply over the entire roof surface.
- B. Flashings: Install flashings to cover underlayment to comply with requirements specified in Section 076200 "Sheet Metal Flashing and Trim."

3.3 INSTALLATION OF STANDING-SEAM METAL ROOF PANELS

- A. Standing-Seam Metal Roof Panel Installation: Fasten metal roof panels to supports with concealed clips at each standing-seam joint at location, spacing, and with fasteners recommended in writing by manufacturer.
 1. Install clips to supports with self-tapping fasteners.
 2. Install pressure plates at locations indicated in manufacturer's written installation instructions.
 3. Seamed Joint: Crimp standing seams with manufacturer-approved, motorized seamer tool so clip, metal roof panel, and factory-applied sealant are completely engaged.
 4. Watertight Installation:
 - a. Apply a continuous ribbon of sealant or tape to seal joints of metal panels, using sealant or tape as recommend in writing by manufacturer as needed to make panels watertight.
 - b. Provide sealant or tape between panels and protruding equipment, vents, and accessories.
 - c. At panel splices, nest panels with minimum 6-inch end lap, sealed with sealant and fastened together by interlocking clamping plates.

- B. Accessory Installation: Install accessories with positive anchorage to building and weathertight mounting, and provide for thermal expansion. Coordinate installation with flashings and other components.
- C. Flashing and Trim: Comply with performance requirements, manufacturer's written installation instructions, and SMACNA's "Architectural Sheet Metal Manual." Provide concealed fasteners where possible, and set units true to line and level as indicated. Install work with laps, joints, and seams that will be permanently watertight and weather resistant.

3.4 CLEANING AND PROTECTION

- A. Remove temporary protective coverings and strippable films, if any, as metal panels are installed, unless otherwise indicated in manufacturer's written installation instructions. On completion of metal panel installation, clean finished surfaces as recommended by metal panel manufacturer. Maintain in a clean condition during construction.

END OF SECTION

SECTION 074293 - SOFFIT PANELS

PART 1 - GENERAL

1.1 SUMMARY

A. Section Includes:

1. Metal soffit panels.

1.2 PREINSTALLATION MEETINGS

- A. Preinstallation Conference: Conduct conference at Project site.

1.3 ACTION SUBMITTALS

- A. Product Data: For each type of product.
- B. Shop Drawings: Include fabrication and installation layouts of metal panels; details of edge conditions, joints, panel profiles, corners, anchorages, attachment system, trim, flashings, closures, and accessories; and special details.
- C. Samples: For each type of metal panel indicated.

1.4 INFORMATIONAL SUBMITTALS

- A. Warranties: Samples of special warranties.

1.5 WARRANTY

- A. Special Warranty: Manufacturer's standard form in which manufacturer agrees to repair or replace components of metal panel systems that fail in materials or workmanship within specified warranty period.
 1. Warranty Period: Two years from date of Final Completion.
- B. Special Warranty on Panel Finishes: Manufacturer's standard form in which manufacturer agrees to repair finish or replace metal panels that show evidence of deterioration of factory-applied finishes within specified warranty period.
 1. Finish Warranty Period: 20 years from date of Final Completion.

PART 2 - PRODUCTS

2.1 PERFORMANCE REQUIREMENTS

- A. Recycled Content: Postconsumer recycled content plus one-half of preconsumer recycled content not less than 25 percent.
- B. Structural Performance: Provide metal panel systems capable of withstanding the effects of the following loads, based on testing according to ASTM E1592:
 - 1. Wind Loads: As indicated on Drawings.
 - 2. Other Design Loads: As indicated on Drawings.
 - 3. Deflection Limits: For wind loads, no greater than 1/240 of the span.
- C. Air Infiltration: Air leakage of not more than 0.06 cfm/sq. ft. when tested according to ASTM E283 at the following test-pressure difference:
 - 1. Test-Pressure Difference: 6.24 lbf/sq. ft..
- D. Water Penetration under Static Pressure: No water penetration when tested according to ASTM E331 at the following test-pressure difference:
 - 1. Test-Pressure Difference: 6.24 lbf/sq. ft..
- E. Thermal Movements: Allow for thermal movements from ambient and surface temperature changes by preventing buckling, opening of joints, overstressing of components, failure of joint sealants, failure of connections, and other detrimental effects. Base calculations on surface temperatures of materials due to both solar heat gain and nighttime-sky heat loss.
 - 1. Temperature Change (Range): 120 deg F, ambient; 180 deg F, material surfaces.

2.2 METAL SOFFIT PANELS

- A. Provide metal soffit panels designed to be installed by lapping and interconnecting side edges of adjacent panels and mechanically attaching through panel to supports using concealed fasteners in side laps. Include accessories required for weathertight installation.
- B. Metal Soffit Panels: Match profile and material of metal roof panels.
 - 1. Finish: Match finish and color of metal roof panels.
 - 2. Sealant: Factory applied within interlocking joint.
- C. Reveal-Joint-Profile Metal Soffit Panels : Solid panels formed with vertical panel edges and a flat pan between panel edges; with recessed reveal joint between panels.
 - 1. Manufacturers: Subject to compliance with requirements, provide products by one of the following:

- a. Firestone Building Products.
 - b. ~~*Firestone Metal Products.~~ **Elevate**
 - c. Metal Roofing Systems, Inc.
 - d. PAC-CLAD; Petersen Aluminum Corporation; a Carlisle company.
2. Material: Same material, finish, and color as metal roof panels.
 3. Panel Coverage: 12 inches.
 4. Panel Height: 0.75 inch.

2.3 MISCELLANEOUS MATERIALS

- A. Miscellaneous Metal Subframing and Furring: ASTM C645, cold-formed, metallic-coated steel sheet, ASTM A653/A653M, G90 hot-dip galvanized coating designation or ASTM A792/A792M, Class AZ50 aluminum-zinc-alloy coating designation unless otherwise indicated. Provide manufacturer's standard sections as required for support and alignment of metal panel system.
- B. Panel Accessories: Provide components required for a complete, weathertight panel system including trim, clips, flashings, sealants, gaskets, fillers, closure strips, and similar items. Match material and finish of metal panels unless otherwise indicated.
 1. Closure Strips: Closed-cell, expanded, cellular, rubber or crosslinked, polyolefin-foam or closed-cell laminated polyethylene; minimum 1-inch- thick, flexible closure strips; cut or premolded to match metal panel profile. Provide closure strips where indicated or necessary to ensure weathertight construction.
- C. Flashing and Trim: Provide flashing and trim formed from same material as metal panels as required to seal against weather and to provide finished appearance. Finish flashing and trim with same finish system as adjacent metal panels.
- D. Panel Fasteners: Self-tapping screws designed to withstand design loads. Provide exposed fasteners with heads matching color of metal panels by means of plastic caps or factory-applied coating. Provide EPDM or PVC sealing washers for exposed fasteners.
- E. Panel Sealants: Provide sealant types recommended by manufacturer that are compatible with panel materials, are nonstaining, and do not damage panel finish.
 1. Butyl-Rubber-Based, Solvent-Release Sealant: ASTM C1311.

2.4 FABRICATION

- A. Fabricate and finish metal panels and accessories at the factory, by manufacturer's standard procedures and processes, as necessary to fulfill indicated performance requirements demonstrated by laboratory testing. Comply with indicated profiles and with dimensional and structural requirements.

- B. Provide panel profile, including major ribs and intermediate stiffening ribs, if any, for full length of panel.
- C. Fabricate metal panel joints with factory-installed captive gaskets or separator strips that provide a weathertight seal and prevent metal-to-metal contact, and that minimize noise from movements.
- D. Sheet Metal Flashing and Trim: Fabricate flashing and trim to comply with manufacturer's recommendations and recommendations in SMACNA's "Architectural Sheet Metal Manual" that apply to design, dimensions, metal, and other characteristics of item indicated.

2.5 FINISHES

- A. Panels and Accessories:
 - 1. Two-Coat Fluoropolymer: AAMA 621. Fluoropolymer finish containing not less than 70 percent polyvinylidene fluoride (PVDF) resin by weight in color coat. Prepare, pretreat, and apply coating to exposed metal surfaces to comply with coating and resin manufacturers' written instructions.

PART 3 - EXECUTION

3.1 PREPARATION

- A. Miscellaneous Supports: Install subframing, furring, and other miscellaneous panel support members and anchorages according to ASTM C754 and metal panel manufacturer's written recommendations.
 - 1. Soffit Framing: Wire tie or clip furring channels to supports, as required to comply with requirements for assemblies indicated.

3.2 INSTALLATION

- A. Metal Soffit Panels: Fasten metal panels to supports with fasteners at each lapped joint at location and spacing recommended by manufacturer.
 - 1. Apply panels and associated items true to line for neat and weathertight enclosure.
 - 2. Provide metal-backed washers under heads of exposed fasteners bearing on weather side of metal panels.
 - 3. Locate and space exposed fasteners in uniform vertical and horizontal alignment. Use proper tools to obtain controlled uniform compression for positive seal without rupture of washer.
 - 4. Install screw fasteners with power tools having controlled torque adjusted to compress washer tightly without damage to washer, screw threads, or panels. Install screws in predrilled holes.

B. Watertight Installation:

1. Apply a continuous ribbon of sealant or tape to seal lapped joints of metal panels, using sealant or tape as recommend by manufacturer on side laps of nesting-type panels and elsewhere as needed to make panels watertight.
2. Provide sealant or tape between panels and protruding equipment, vents, and accessories.
3. At panel splices, nest panels with minimum 6-inch end lap, sealed with sealant and fastened together by interlocking clamping plates.

C. Accessory Installation: Install accessories with positive anchorage to building and weathertight mounting, and provide for thermal expansion. Coordinate installation with flashings and other components.

D. Flashing and Trim: Comply with performance requirements, manufacturer's written installation instructions, and SMACNA's "Architectural Sheet Metal Manual." Provide concealed fasteners where possible, and set units true to line and level as indicated. Install work with laps, joints, and seams that are permanently watertight.

3.3 CLEANING

- A. Remove temporary protective coverings and strippable films, if any, as metal panels are installed unless otherwise indicated in manufacturer's written installation instructions. On completion of metal panel installation, clean finished surfaces as recommended by metal panel manufacturer. Maintain in a clean condition during construction.

END OF SECTION

SECTION 084113 - ALUMINUM-FRAMED ENTRANCES AND STOREFRONTS

PART 1 - GENERAL

1.1 SUMMARY

A. Section Includes:

1. Aluminum-framed storefront systems.
2. Aluminum-framed entrance door systems.

1.2 ACTION SUBMITTALS

A. Product Data: For each type of product.

1. Include construction details, material descriptions, dimensions of individual components and profiles, and finishes.

B. Shop Drawings: For aluminum-framed entrances and storefronts. Include plans, elevations, sections, full-size details, and attachments to other work.

1. Show connection to and continuity with adjacent thermal, weather, air, and vapor barriers.
2. Include point-to-point wiring diagrams.

C. Samples: For each type of exposed finish required.

1.3 CLOSEOUT SUBMITTALS

A. Operation and maintenance data.

1.4 WARRANTY

A. Special Warranty: Manufacturer agrees to repair or replace components of aluminum-framed entrances and storefronts that do not comply with requirements or that fail in materials or workmanship within specified warranty period.

1. Warranty Period: Five years from date of Final Completion.

B. Special Finish Warranty, Anodized Finishes: Standard form in which manufacturer agrees to repair finishes or replace aluminum that shows evidence of deterioration of anodized finishes within specified warranty period.

1. Warranty Period: 10 years from date of Final Completion.

PART 2 - PRODUCTS

2.1 PERFORMANCE REQUIREMENTS

- A. General Performance: Comply with performance requirements specified, as determined by testing of aluminum-framed entrances and storefronts representing those indicated for this Project without failure due to defective manufacture, fabrication, installation, or other defects in construction.
1. Aluminum-framed entrances and storefronts shall withstand movements of supporting structure, including, but not limited to, twist, column shortening, long-term creep, and deflection from uniformly distributed and concentrated live loads.
 2. Failure also includes the following:
 - a. Thermal stresses transferring to building structure.
 - b. Glass breakage.
 - c. Noise or vibration created by wind and thermal and structural movements.
 - d. Loosening or weakening of fasteners, attachments, and other components.
 - e. Failure of operating units.
- B. Structural Loads:
1. Wind Loads: As indicated on Drawings.
 2. Other Design Loads: As indicated on Drawings.
- C. Deflection of Framing Members Supporting Glass: At design wind load, as follows:
1. Deflection Normal to Wall Plane: Limited to 1/175 of clear span for spans of up to 13 feet 6 inches and to 1/240 of clear span plus 1/4 inch for spans greater than 13 feet 6 inches.
 2. Deflection Parallel to Glazing Plane: Limited to amount not exceeding that which reduces glazing bite to less than 75 percent of design dimension and that which reduces edge clearance between framing members and glazing or other fixed components to less than 1/8 inch.
 - a. Operable Units: Provide a minimum 1/16-inch clearance between framing members and operable units.
 3. Cantilever Deflection: Limited to $2L/175$ at unsupported cantilevers.
- D. Structural: Test in accordance with ASTM E330/E330M as follows:
1. When tested at positive and negative wind-load design pressures, storefront assemblies, including entrance doors, do not evidence deflection exceeding specified limits.

2. When tested at 150 percent of positive and negative wind-load design pressures, storefront assemblies, including entrance doors and anchorage, do not evidence material failures, structural distress, or permanent deformation of main framing members exceeding 0.2 percent of span.
 3. Test Durations: As required by design wind velocity, but not less than 10 seconds.
- E. Water Penetration under Static Pressure: Test in accordance with ASTM E331 as follows:
1. No evidence of water penetration through fixed glazing and framing areas, including entrance doors, when tested in accordance with a minimum static-air-pressure differential of 20 percent of positive wind-load design pressure, but not less than 10 lbf/sq. ft..
- F. Energy Performance: Certified and labeled by manufacturer for energy performance as follows:
1. Thermal Transmittance (U-factor):
 - a. Fixed Glazing and Framing Areas: U-factor for the system of not more than 0.45 Btu/sq. ft. x h x deg F as determined in accordance with NFRC 100.
 - b. Entrance Doors: U-factor of not more than 0.83 Btu/sq. ft. x h x deg F as determined in accordance with NFRC 100.
 2. Solar Heat-Gain Coefficient (SHGC):
 - a. Fixed Glazing and Framing Areas: SHGC for the system of not more than 0.40 as determined in accordance with NFRC 200.
 - b. Entrance Doors: SHGC of not more than 0.40 as determined in accordance with NFRC 200.
 3. Air Leakage:
 - a. Fixed Glazing and Framing Areas: Air leakage for the system of not more than 0.06 cfm/sq. ft. at a static-air-pressure differential of 6.24 lbf/sq. ft. when tested in accordance with ASTM E283.
 - b. Entrance Doors: Air leakage of not more than 1.0 cfm/sq. ft. at a static-air-pressure differential of 1.57 lbf/sq. ft..
 4. Condensation Resistance Factor (CRF):
 - a. Fixed Glazing and Framing Areas: CRF for the system of not less than 55 as determined in accordance with AAMA 1503.
 - b. Entrance Doors: CRF of not less than 63 as determined in accordance with AAMA 1503.
- G. Thermal Movements: Allow for thermal movements resulting from ambient and surface temperature changes.

1. Temperature Change: 120 deg F, ambient; 180 deg F, material surfaces.

2.2 STOREFRONT SYSTEMS

- A. Manufacturers: Subject to compliance with requirements, provide products by one of the following:
 1. EFCO Corporation.
 2. Kawneer North America, an Arconic company.
 3. U.S. Aluminum; a brand of C.R. Laurence.
 4. YKK AP America Inc.
- B. Framing Members: Manufacturer's extruded- or formed-aluminum framing members of thickness required and reinforced as required to support imposed loads.
 1. Exterior Framing Construction: Thermally broken.
 2. Glazing System: Retained mechanically with gaskets on four sides.
 3. Finish: Clear anodic finish.
 4. Fabrication Method: Field-fabricated stick system.
 5. Aluminum: Alloy and temper recommended by manufacturer for type of use and finish indicated.
 6. Steel Reinforcement: As required by manufacturer.
- C. Backer Plates: Manufacturer's standard, continuous backer plates for framing members, if not integral, where framing abuts adjacent construction.
- D. Brackets and Reinforcements: Manufacturer's standard high-strength aluminum with nonstaining, nonferrous shims for aligning system components.

2.3 ENTRANCE DOOR SYSTEMS

- A. Manufacturers: Subject to compliance with requirements, provide products by one of the following:
 1. EFCO Corporation.
 2. Kawneer North America, an Arconic company.
 3. U.S. Aluminum; a brand of C.R. Laurence.
 4. YKK AP America Inc.
- B. Entrance Doors: Manufacturer's standard glazed entrance doors for manual-swing or automatic operation.
 1. Door Construction: 1-3/4-inch overall thickness, with minimum 0.125-inch-thick, extruded-aluminum tubular rail and stile members. Mechanically fasten corners with reinforcing brackets that are deeply penetrated and fillet welded or that incorporate concealed tie rods.
 2. Door Design: As indicated.

3. Glazing Stops and Gaskets: Square, snap-on, extruded-aluminum stops and preformed gaskets.
 - a. Provide nonremovable glazing stops on outside of door.

2.4 ENTRANCE DOOR HARDWARE

2.5 GLAZING

- A. Glazing: Comply with Section 088000 "Glazing."

2.6 *SCREENS

- A. **Screens: Basis of Design Product: EFCO Screen Frame #3108 with Gun Metal Screen Mesh Glazed into Storefronts**

2.7 MATERIALS

- A. Sheet and Plate: ASTM B209.
- B. Extruded Bars, Rods, Profiles, and Tubes: ASTM B221.
- C. Structural Profiles: ASTM B308/B308M.
- D. Steel Reinforcement:
 1. Structural Shapes, Plates, and Bars: ASTM A36/A36M.
 2. Cold-Rolled Sheet and Strip: ASTM A1008/A1008M.
 3. Hot-Rolled Sheet and Strip: ASTM A1011/A1011M.
- E. Steel Reinforcement Primer: Manufacturer's standard zinc-rich, corrosion-resistant primer complying with SSPC-PS Guide No. 12.00; applied immediately after surface preparation and pretreatment. Select surface preparation methods in accordance with recommendations in SSPC-SP COM, and prepare surfaces in accordance with applicable SSPC standard.
- F. Recycled Content of Steel Products: Postconsumer recycled content plus one-half of preconsumer recycled content not less than 25 percent.
- G. Recycled Content of Aluminum Components: Postconsumer recycled content plus one-half of preconsumer recycled content not less than 25 percent.

2.8 FABRICATION

- A. Form or extrude aluminum shapes before finishing.

- B. Weld in concealed locations to greatest extent possible to minimize distortion or discoloration of finish. Remove weld spatter and welding oxides from exposed surfaces by descaling or grinding.
- C. Fabricate components that, when assembled, have the following characteristics:
 - 1. Profiles that are sharp, straight, and free of defects or deformations.
 - 2. Accurately fitted joints with ends coped or mitered.
 - 3. Physical and thermal isolation of glazing from framing members.
 - 4. Accommodations for thermal and mechanical movements of glazing and framing to maintain required glazing edge clearances.
 - 5. Provisions for field replacement of glazing from interior.
 - 6. Fasteners, anchors, and connection devices that are concealed from view to greatest extent possible.
- D. Mechanically Glazed Framing Members: Fabricate for flush glazing without projecting stops.
- E. Entrance Door Frames: Reinforce as required to support loads imposed by door operation and for installing entrance door hardware.
- F. Entrance Doors: Reinforce doors as required for installing entrance door hardware.
- G. Entrance Door Hardware Installation: Factory install entrance door hardware to the greatest extent possible. Cut, drill, and tap for factory-installed entrance door hardware before applying finishes.
- H. After fabrication, clearly mark components to identify their locations in Project in accordance with Shop Drawings.

2.9 ALUMINUM FINISHES

- A. Clear Anodic Finish: AAMA 611, AA-M12C22A41, Class I, 0.018 mm or thicker.

PART 3 - EXECUTION

3.1 INSTALLATION, GENERAL

- A. Comply with manufacturer's written instructions.
- B. Do not install damaged components.
- C. Fit joints to produce hairline joints free of burrs and distortion.
- D. Rigidly secure nonmovement joints.
- E. Install anchors with separators and isolators to prevent metal corrosion and electrolytic deterioration and to prevent impeding movement of moving joints.

- F. Seal perimeter and other joints watertight unless otherwise indicated.
 - G. Metal Protection:
 - 1. Where aluminum is in contact with dissimilar metals, protect against galvanic action by painting contact surfaces with materials recommended by manufacturer for this purpose or by installing nonconductive spacers.
 - 2. Where aluminum is in contact with concrete or masonry, protect against corrosion by painting contact surfaces with bituminous paint.
 - H. Set continuous sill members and flashing in full sealant bed, as specified in Section 079200 "Joint Sealants," to produce weathertight installation.
 - I. Install joint filler behind sealant as recommended by sealant manufacturer.
 - J. Install components plumb and true in alignment with established lines and grades.
- 3.2 INSTALLATION OF GLAZING
- A. Install glazing as specified in Section 088000 "Glazing."
- 3.3 INSTALLATION OF ALUMINUM-FRAMED ENTRANCE DOORS
- A. Install entrance doors to produce smooth operation and tight fit at contact points.
 - 1. Exterior Doors: Install to produce weathertight enclosure and tight fit at weather stripping.
 - 2. Field-Installed Entrance Door Hardware: Install surface-mounted entrance door hardware in accordance with entrance door hardware manufacturers' written instructions using concealed fasteners to greatest extent possible.
- 3.4 FIELD QUALITY CONTROL
- A. Testing Agency: Owner will engage a qualified testing agency to perform tests and inspections.
 - B. Tests and Inspections: Perform the following test on representative areas of aluminum-framed entrances and storefronts.
 - 1. Water-Spray Test: Before installation of interior finishes has begun, areas designated by Architect shall be tested in accordance with AAMA 501.2 and shall not evidence water penetration.
 - a. Perform a minimum of two tests in areas as directed by Architect.
 - 2. Air Leakage: ASTM E783 at 1.5 times the rate specified for laboratory testing in "Performance Requirements" Article but not more than 0.09 cfm/sq. ft. at a static-air-pressure differential of 1.57 lbf/sq. ft..

- a. Perform a minimum of two tests in areas as directed by Architect.
3. Water Penetration: ASTM E1105 at a minimum uniform static-air-pressure differential of 0.67 times the static-air-pressure differential specified for laboratory testing in "Performance Requirements" Article, but not less than 6.24 lbf/sq. ft., and shall not evidence water penetration.
- C. Aluminum-framed entrances and storefronts will be considered defective if they do not pass tests and inspections.
 - D. Prepare test and inspection reports.

END OF SECTION

SECTION 230923 - DIRECT DIGITAL CONTROL (DDC) SYSTEM FOR HVAC

PART 1 - GENERAL

1.1 SUMMARY

- A. Section Includes: Direct digital control (DDC) system for HVAC.

1.2 DEFINITIONS

- A. Algorithm: A logical procedure for solving a recurrent mathematical problem. A prescribed set of well-defined rules or processes for solving a problem in a finite number of steps.
- B. Analog: A continuously varying signal value, such as current, flow, pressure, or temperature.
- C. BACnet Specific Definitions:
 - 1. BACnet: Building Automation Control Network Protocol, ASHRAE 135. A communications protocol allowing devices to communicate data and services over a network.
 - 2. BACnet Interoperability Building Blocks (BIBBs): BIBB defines a small portion of BACnet functionality that is needed to perform a particular task. BIBBs are combined to build the BACnet functional requirements for a device.
 - 3. BACnet/IP: Defines and allows using a reserved UDP socket to transmit BACnet messages over IP networks. A BACnet/IP network is a collection of one or more IP subnetworks that share the same BACnet network number.
 - 4. BACnet Testing Laboratories (BTL): Organization responsible for testing products for compliance with ASHRAE 135, operated under direction of BACnet International.
- D. Binary: Two-state signal where a high signal level represents "ON" or "OPEN" condition and a low signal level represents "OFF" or "CLOSED" condition. "Digital" is sometimes used interchangeably with "Binary" to indicate a two-state signal.
- E. Controller: Generic term for any standalone, microprocessor-based, digital controller residing on a network, used for local or global control. Three types of controllers are indicated: network controllers, programmable application controllers, and application-specific controllers.
- F. Control System Integrator: An entity that assists in expansion of existing enterprise system and support of additional operator interfaces to I/O being added to existing enterprise system.
- G. COV: Changes of value.
- H. DDC System Provider: Authorized representative of, and trained by, DDC system manufacturer and responsible for execution of DDC system Work indicated.

- I. Distributed Control: Processing of system data is decentralized and control decisions are made at subsystem level. System operational programs and information are provided to remote subsystems and status is reported back. On loss of communication, subsystems to be capable of operating in a standalone mode using the last best available data.
- J. Gateway: Bidirectional protocol translator that connects control systems that use different communication protocols.
- K. HLC: Heavy load conditions.
- L. I/O: System through which information is received and transmitted. I/O refers to analog input (AI), binary input (BI), analog output (AO) and binary output (BO). Analog signals are continuous and represent control influences such as flow, level, moisture, pressure, and temperature. Binary signals convert electronic signals to digital pulses (values) and generally represent two-position operating and alarm status. "Digital," (DI) and (DO), is sometimes used interchangeably with "Binary," (BI) and (BO), respectively.
- M. LAN: Local area network.
- N. LNS: LonWorks Network Services.
- O. LON Specific Definitions:
 - 1.FTT-10: Echelon Transmitter-Free Topology Transceiver.
 - 2.LonMark International: Association comprising suppliers and installers of LonTalk products. Association provides guidelines for implementing LonTalk protocol to ensure interoperability through a standard or consistent implementation.
 - 3.LonTalk: An open standard protocol developed by Echelon Corporation that uses a "Neuron Chip" for communication. LonTalk is a register trademark of Echelon.
 - 4.LonWorks: Network technology developed by Echelon.
 - 5.Node: Device that communicates using CTA-709.1-D protocol and that is connected to a CTA-709.1-D network.
 - 6.Node Address: The logical address of a node on the network, consisting of a Domain number, Subnet number, and Node number. "Node number" portion of an address is a number assigned to device during installation, is unique within a subnet, and is not a factory-set unique Node ID.
 - 7.Node ID: A unique 48-bit identifier assigned at factory to each CTA-709.1-D device. Sometimes called a "Neuron ID."
 - 8.Program ID: An identifier (number) stored in a device (usually, EEPROM) that identifies node manufacturer, functionality of device (application and sequence), transceiver used, and intended device usage.
 - 9.Standard Configuration Property Type (SCPT): Pronounced "skip-it." A standard format type maintained by LonMark for configuration properties.
 - 10. Standard Network Variable Type (SNVT): Pronounced "snivet." A standard format type maintained by LonMark used to define data information transmitted and received by individual nodes. "SNVT" is used in two ways. It is an acronym for "Standard Network Variable Type" and is often used to indicate a network variable itself (i.e., it can mean "a network variable of a standard network variable type").
 - 11. Subnet: Consists of a logical grouping of up to 127 nodes, where logical grouping is defined by node addressing. Each subnet is assigned a number, which is unique within a Domain. See "Node Address."

12. TP/FT-10: Free Topology Twisted Pair network defined by CTA-709.3 and is most common media type for a CTA-709.1-D control network.
 13. TP/XF-1250: High-speed, 1.25 Mbps, twisted-pair, doubly terminated bus network defined by "LonMark Interoperability Guidelines" and typically used only to connect multiple TP/FT-10 networks.
 14. User-Defined Configuration Property Type (UCPT): Pronounced "u-keep-it." A Configuration Property format type that is defined by device manufacturer.
 15. User-Defined Network Variable Type (UNVT): Network variable format defined by device manufacturer. UNVTs create non-standard communications that other vendors' devices may not correctly interpret and may negatively impact system operation. UNVTs are not allowed.
- P. Low Voltage: As defined in NFPA 70 for circuits and equipment operating at less than 50 V or for remote-control, signaling power-limited circuits.
- Q. Mobile Device: A data-enabled phone or tablet computer capable of connecting to a cellular data network and running a native control application or accessing a web interface.
- R. Modbus TCP/IP: An open protocol for exchange of process data.
- S. MS/TP: Master-slave/token-passing, ISO/IEC/IEEE 8802-3. Datalink protocol LAN option that uses twisted-pair wire for low-speed communication.
- T. MTBF: Mean time between failures.
- U. Network Controller: Digital controller, which supports a family of programmable application controllers and application-specific controllers, that communicates on peer-to-peer network for transmission of global data.
- V. Network Repeater: Device that receives data packet from one network and rebroadcasts it to another network. No routing information is added to protocol.
- W. Peer to Peer: Networking architecture that treats all network stations as equal partners.
- X. POT: Portable operator's terminal.
- Y. RAM: Random access memory.
- Z. RF: Radio frequency.
- AA. Router: Device connecting two or more networks at network layer.
- BB. Server: Computer used to maintain system configuration, historical and programming database.
- CC. TCP/IP: Transport control protocol/Internet protocol.
- DD. UPS: Uninterruptible power supply.
- EE. USB: Universal Serial Bus.

FF. User Datagram Protocol (UDP): This protocol assumes that the IP is used as the underlying protocol.

GG. VAV: Variable air volume.

HH. WLED: White light emitting diode.

1.3 ACTION SUBMITTALS

A. Multiple Submissions:

1. If multiple submissions are required to execute work within schedule, first submit a coordinated schedule clearly defining intent of multiple submissions. Include a proposed date of each submission with a detailed description of submittal content to be included in each submission.
2. Clearly identify each submittal requirement indicated and in which submission the information will be provided.
3. Include an updated schedule in each subsequent submission with changes highlighted to easily track the changes made to previous submitted schedule.

B. Product Data:

1. Construction details, material descriptions, dimensions of individual components and profiles, and finishes.
2. Operating characteristics, electrical characteristics, and furnished accessories indicating process operating range, accuracy over range, control signal over range, default control signal with loss of power, calibration data specific to each unique application, electrical power requirements, and limitations of ambient operating environment, including temperature and humidity.
3. Product description with complete technical data, performance curves, and product specification sheets.
4. Installation, operation, and maintenance instructions including factors effecting performance.
5. Bill of materials of indicating quantity, manufacturer, and extended model number for each unique product.
 - a. Servers.
 - b. Gateways.
 - c. Protocol analyzers.
 - d. DDC controllers.
 - e. Enclosures.
 - f. Electrical power devices.
 - g. UPS units.
 - h. Accessories.
 - i. Instruments.
 - j. Control dampers and actuators.
 - k. Control valves and actuators.
6. When manufacturer's product datasheets apply to a product series rather than a specific product model, clearly indicate and highlight only applicable information.

7. Each submitted piece of product literature to clearly cross reference specification and drawings that submittal is to cover.

C. Software Submittal:

1. Cross-referenced listing of software to be loaded on each operator workstation, server, gateway, and DDC controller.
2. Description and technical data of all software provided and cross-referenced to products in which software will be installed.
3. Operating system software, operator interface and programming software, color graphic software, DDC controller software, maintenance management software, and third-party software.
4. Include a flow diagram and an outline of each subroutine that indicates each program variable name and units of measure.
5. Listing and description of each engineering equation used with reference source.
6. Listing and description of each constant used in engineering equations and a reference source to prove origin of each constant.
7. Description of operator interface to alphanumeric and graphic programming.
8. Description of each network communication protocol.
9. Description of system database, including all data included in database, database capacity, and limitations to expand database.
10. Description of each application program and device drivers to be generated, including specific information on data acquisition and control strategies showing their relationship to system timing, speed, processing burden, and system throughout.
11. Controlled Systems: Instrumentation list with element name, type of device, manufacturer, model number, and product data. Include written description of sequence of operation including schematic diagram.

D. Shop Drawings:

1. General Requirements:

- a. Include cover drawing with Project name, location, Owner, Architect, Contractor, and issue date with each Shop Drawings submission.
 - b. Include a drawing index sheet listing each drawing number and title that matches information in each title block.
2. Include plans, elevations, sections, and mounting details where applicable.
 3. Include details of product assemblies. Indicate dimensions, weights, loads, required clearances, method of field assembly, components, and location and size of each field connection.
 4. Detail means of vibration isolation and show attachments to rotating equipment.
 5. Plan Drawings indicating the following:
 - a. Screened backgrounds of walls, structural grid lines, HVAC equipment, ductwork, and piping.
 - b. Room names and numbers with coordinated placement to avoid interference with control products indicated.
 - c. Exact placement of products in rooms, ducts, and piping to reflect proposed installed condition.
 - d. Network communication cable and raceway routing.

- e. Proposed routing of wiring, cabling, conduit, and tubing; coordinated with building services for review before installation.

6. Schematic drawings for each controlled HVAC system indicating the following:

- a. I/O points labeled with point names shown. Indicate instrument range, normal operating set points, and alarm set points. Indicate fail position of each damper and valve, if included in Project.
- b. I/O listed in table format showing point name, type of device, manufacturer, model number, and cross-reference to product data sheet number.
- c. A graphic showing location of control I/O in proper relationship to HVAC system.
- d. Wiring diagram with each I/O point having a unique identification and indicating labels for all wiring terminals.
- e. Unique identification of each I/O that to be consistently used between different drawings showing same point.
- f. Elementary wiring diagrams of controls for HVAC equipment motor circuits including interlocks, switches, relays, and interface to DDC controllers.
- g. Narrative sequence of operation.
- h. Graphic sequence of operation, showing all inputs and output logical blocks.

7. Control panel drawings indicating the following:

- a. Panel dimensions, materials, size, and location of field cable, raceways, and tubing connections.
- b. Interior subpanel layout, drawn to scale and showing all internal components, cabling and wiring raceways, nameplates, and allocated spare space.
- c. Front, rear, and side elevations and nameplate legend.
- d. Unique drawing for each panel.

8. DDC system network riser diagram indicating the following:

- a. Each device connected to network with unique identification for each.
- b. Interconnection of each different network in DDC system.
- c. For each network, indicate communication protocol, speed, and physical means of interconnecting network devices, such as copper cable type, or optical fiber cable type. Indicate raceway type and size for each.
- d. Each network port for connection of an operator workstation or other type of operator interface with unique identification for each.

9. DDC system electrical power riser diagram indicating the following:

- a. Each point of connection to field power with requirements (volts/phase/hertz/amperes/connection type) listed for each.
- b. Each control power supply including, as applicable, transformers, power-line conditioners, transient voltage suppression and high filter noise units, DC power supplies, and UPS units with unique identification for each.
- c. Each product requiring power with requirements (volts/phase/hertz/amperes/connection type) listed for each.
- d. Power wiring type and size, race type, and size for each.

10. Monitoring and control signal diagrams indicating the following:

- a. Control signal cable and wiring between controllers and I/O.
 - b. Point-to-point schematic wiring diagrams for each product.
 - c. Control signal tubing to sensors, switches, and transmitters.
 - d. Process signal tubing to sensors, switches, and transmitters.
11. Color graphics indicating the following:
- a. Itemized list of color graphic displays to be provided.
 - b. For each display screen to be provided, a true color copy showing layout of pictures, graphics, and data displayed.
 - c. Intended operator access between related hierarchical display screens.
- E. System Description:
1. Full description of DDC system architecture, network configuration, operator interfaces and peripherals, servers, controller types and applications, gateways, routers and other network devices, and power supplies.
 2. Complete listing and description of each report, log and trend for format and timing, and events that initiate generation.
 3. System and product operation under each potential failure condition including, but not limited to, the following:
 - a. Loss of power.
 - b. Loss of network communication signal.
 - c. Loss of controller signals to inputs and outpoints.
 - d. Operator workstation failure.
 - e. Server failure.
 - f. Gateway failure.
 - g. Network failure.
 - h. Controller failure.
 - i. Instrument failure.
 - j. Control damper and valve actuator failure.
 4. Complete bibliography of documentation and media to be delivered to Owner.
 5. Description of testing plans and procedures.
 6. Description of Owner training.
- F. Delegated Design Submittals: For DDC system products and installation indicated as being delegated.
1. Supporting documentation showing DDC system design complies with performance requirements indicated, including calculations and other documentation necessary to prove compliance.
 2. Schedule and design calculations for control dampers and actuators.
 - a. Flow at Project design and minimum flow conditions.
 - b. Face velocity at Project design and minimum airflow conditions.
 - c. Pressure drop across damper at Project design and minimum airflow conditions.
 - d. AMCA 500-D damper installation arrangement used to calculate and schedule pressure drop, as applicable to installation.
 - e. Maximum close-off pressure.

- f. Leakage airflow at maximum system pressure differential (fan close-off pressure).
- g. Torque required at worst case condition for sizing actuator.
- h. Actuator selection indicating torque provided.
- i. Actuator signal to control damper (on, close, or modulate).
- j. Actuator position on loss of power.
- k. Actuator position on loss of control signal.

3. Schedule and design calculations for control valves and actuators.

- a. Flow at Project design and minimum flow conditions.
- b. Pressure-differential drop across valve at Project design flow condition.
- c. Maximum system pressure-differential drop (pump close-off pressure) across valve at Project minimum flow condition.
- d. Design and minimum control valve coefficient with corresponding valve position.
- e. Maximum close-off pressure.
- f. Leakage flow at maximum system pressure differential.
- g. Torque required at worst case condition for sizing actuator.
- h. Actuator selection indicating torque provided.
- i. Actuator signal to control damper (on, close or modulate).
- j. Actuator position on loss of power.
- k. Actuator position on loss of control signal.

4. Schedule and design calculations for selecting flow instruments.

- a. Instrument flow range.
- b. Project design and minimum flow conditions with corresponding accuracy, control signal to transmitter, and output signal for remote control.
- c. Extreme points of extended flow range with corresponding accuracy, control signal to transmitter, and output signal for remote control.
- d. Pressure-differential loss across instrument at Project design flow conditions.
- e. Where flow sensors are mated with pressure transmitters, provide information for each instrument separately and as an operating pair.

G. Sustainable Design Submittals:

1.4 INFORMATIONAL SUBMITTALS

A. Coordination Drawings:

- 1. Plan drawings, reflected ceiling plans, or Building Information Model (BIM), and corresponding product installation details, drawn to scale, showing the items described in this Section and coordinated with all building trades.

B. Qualification Statements:

1. Systems Provider's Qualification Data:

- a. Resume of project manager assigned to Project.
- b. Resumes of application engineering staff assigned to Project.
- c. Resumes of installation and programming technicians assigned to Project.

- d. Resumes of service technicians assigned to Project.
- e. Brief description of past project including physical address, floor area, number of floors, building system cooling and heating capacity, and building's primary function.
- f. Description of past project DDC system, noting similarities to Project scope and complexity indicated.
- g. Names of staff assigned to past project that will also be assigned to execute work of this Project.
- h. Owner contact information for past project including name, phone number, and email address.
- i. Contractor contact information for past project including name, phone number, and email address.
- j. Architect and Engineer contact information for past project including name, phone number, and email address.

2. Manufacturer's qualification data.

3. Testing agency's qualification data.

C. Welding certificates.

D. Product Certificates:

1. Data Communications Protocol Certificates:

- a. Certifying that each proposed DDC system component complies with ASHRAE 135.

E. Test and Evaluation Reports:

1. Product Test Reports: For DDC system equipment and components, for tests performed by manufacturer and witnessed by a qualified testing agency.
2. Preconstruction Test Reports: For each separate test performed.

F. Source Quality-Control Reports: For DDC system equipment and components.

G. Field Quality-Control Reports: For DDC system equipment and components.

H. Sample warranty.

1.5 CLOSEOUT SUBMITTALS

A. Operation and Maintenance Data: For DDC system.

1. In addition to items specified in Section 017823 "Operation and Maintenance Data," include the following:

- a. Project Record Drawings of as-built versions of submittal Shop Drawings provided in electronic PDF format.
- b. Testing and commissioning reports and checklists of completed final versions of reports, checklists, and trend logs.
- c. As-built versions of submittal Product Data.

- d. Names, addresses, email addresses, and 24-hour telephone numbers of Installer and service representatives for DDC system and products.
- e. Operator's manual with procedures for operating control systems including logging on and off, handling alarms, producing point reports, trending data, overriding computer control, and changing set points and variables.
- f. Programming manuals with description of programming language and syntax, of statements for algorithms and calculations used, of point database creation and modification, of program creation and modification, and of editor use.
- g. Engineering, installation, and maintenance manuals that explain how to do the following:
 - 1) Design and install new points, panels, and other hardware.
 - 2) Perform preventive maintenance and calibration.
 - 3) Debug hardware problems.
 - 4) Repair or replace hardware.
- h. Documentation of all programs created using custom programming language including set points, tuning parameters, and object database.
- i. Backup copy of graphic files, programs, and databases on electronic media.
- j. List of recommended spare parts with part numbers and suppliers.
- k. Complete original-issue documentation, installation, and maintenance information for furnished third-party hardware including computer equipment and sensors.
- l. Complete original-issue copies of furnished software, including operating systems, custom programming language, operator workstation software, and graphics software.
- m. Licenses, guarantees, and warranty documents.
- n. Recommended preventive maintenance procedures for system components, including schedule of tasks such as inspection, cleaning, and calibration; time between tasks; and task descriptions.
- o. Owner training materials.

1.6 MAINTENANCE MATERIAL SUBMITTALS

- A. Extra Stock Material: Furnish extra materials and parts to Owner that match products installed and that are packaged with protective covering for storage and identified with labels describing contents.
- B. Include product manufacturers' recommended parts lists for proper product operation over four-year period following warranty period. Parts list to be indicated for each year.
- C. Furnish parts, as indicated by manufacturer's recommended parts list, for product operation during one-year period following warranty period.
- D. Furnish quantity indicated of matching product(s) in Project inventory for each unique size and type of following:
 - 1. Network Controller: One.
 - 2. Programmable Application Controller: One.
 - 3. Application-Specific Controller: One.
 - 4. General-Purpose Relay: One.

5. Multifunction Time-Delay Relay: One.
6. Latching Relay: One.
7. Current-Sensing Relay: One.
8. Combination On-Off Status Sensor and On-Off Relay: One.
9. Transformer: One.
10. DC Power Supply: One.

1.7 QUALITY ASSURANCE

A. DDC System Manufacturer Qualifications:

1. Nationally recognized manufacturer of DDC systems and products.
2. DDC systems with similar requirements to those indicated for a continuous period of five years within time of bid.
3. DDC systems and products that have been successfully tested and in use on at least five past projects.
4. Having complete published catalog literature, installation, operation, and maintenance manuals for all products intended for use.
5. Having full-time in-house employees for the following:
 - a. Product research and development.
 - b. Product and application engineering.
 - c. Product manufacturing, testing, and quality control.
 - d. Technical support for DDC system installation training, commissioning, and troubleshooting of installations.
 - e. Owner operator training.

B. DDC System Provider Qualifications:

1. Authorized representative of, and trained by, DDC system manufacturer.
2. Demonstrate past experience with installation of DDC system products being installed for period within five consecutive years before time of bid.
3. Demonstrate past experience on five projects of similar complexity, scope, and value.
4. Demonstrate past experience of each person assigned to Project.
5. Staffing resources of competent and experienced full-time employees that are assigned to execute work according to schedule.
6. Service and maintenance staff assigned to support Project during warranty period.
7. Product parts inventory to support ongoing DDC system operation for a period of not less than five years after Final Acceptance.
8. DDC system manufacturer's backing to take over execution of the Work if necessary to comply with requirements indicated. Include Project-specific written letter, signed by manufacturer's corporate officer, if requested.

C. Testing Agency Qualifications: Member company of NETA.

1. Testing Agency's Field Supervisor: Certified by NETA to supervise on-site testing.

D. Welding Qualifications: Qualify procedures and personnel in accordance with the following welding codes:

- 1.AWS D1.1/D1.1M.
- 2.AWS D1.2/D1.2M.
- 3.AWS D1.3/D1.3M.
- 4.AWS D1.4/D1.4M.

1.8 WARRANTY

- A. Special Warranty: Manufacturer and Installer agree to repair or replace products that fail in materials or workmanship within specified warranty period.
- 1.Adjust, repair, or replace failures at no additional cost or reduction in service to Owner.
 - 2.Include updates or upgrades to software and firmware if necessary to resolve deficiencies.
 - a. Install updates only after receiving Owner's written authorization.
 - 3.Perform warranty service during normal business hours and commence within 16 hours of Owner's warranty service request.
 - 4.Warranty Period: Two year(s) from date of Final Acceptance.
 - a. For Gateway: Two-year parts and labor warranty for each.

PART 2 - PRODUCTS

2.1 DIRECT DIGITAL CONTROL (DDC) SYSTEM FOR HVAC

- A. Manufacturers: Subject to compliance with requirements, provide products by one of the following:
- 1.Distech Controls.
 - 2.Johnson Controls, Inc. (Preferred)
 - 3.Schneider Electric USA, Inc. (Preferred)

2.2 DDC SYSTEM DESCRIPTION

- A. Microprocessor-based monitoring and control including analog/digital conversion and program logic. A control loop or subsystem in which digital and analog information is received and processed by a microprocessor, and digital control signals are generated based on control algorithms and transmitted to field devices to achieve a set of predefined conditions.
- 1.DDC system consisting of high-speed, peer-to-peer network of distributed DDC controllers, other network devices, operator interfaces, and software.
- B. Electrical Components, Devices, and Accessories: Listed and labeled as defined in NFPA 70, by a qualified testing agency, and marked for intended location and application.

2.3 WEB ACCESS

- A. DDC system to be web based or web compatible.

1. Web-Based Access to DDC System:

- a. DDC system software based on server thin-client architecture, designed around open standards of web technology. DDC system server accessed using a web browser over DDC system network, using Owner's LAN, and remotely over Internet.
- b. Intent of thin-client architecture is to provide operators complete access to DDC system via a web browser. No special software other than a web browser is required to access graphics, point displays, and trends; to configure trends, points, and controllers; and to edit programming.
- c. Password-protected web access.

2. Web-Compatible Access to DDC System:

- a. Workstation and or server to perform overall system supervision and configuration, graphical user interface, management report generation, and alarm annunciation.
- b. DDC system to support web browser access to building data. Operator using a standard web browser is able to access control graphics and change adjustable set points.
- c. Password-protected web access.

2.4 PERFORMANCE REQUIREMENTS

- A. Delivery of Selected Control Devices: Deliver to equipment and systems manufacturers for factory installation and to HVAC systems installers for field installation.
- B. Delegated Design, Qualified Professional Engineer: Engage a qualified professional engineer, as defined in Section 014000 "Quality Requirements," to design DDC system to satisfy requirements indicated.
- C. Delegated Design, Qualified Professional: Engage a qualified professional to design DDC system to satisfy requirements indicated.

1. System Performance Objectives:

- a. DDC system manages HVAC systems.
 - b. DDC system operates HVAC systems to achieve optimum operating costs while using least possible energy and maintaining specified performance.
 - c. DDC system responds to power failures, HVAC equipment failures, and adverse and emergency conditions encountered through connected I/O points.
 - d. DDC system operates while unattended by an operator and through operator interaction.
 - e. DDC system records trends and transactions of events and produces report information such as performance, energy, occupancies, and equipment operation.
- D. Surface-Burning Characteristics: Products installed in ducts, equipment, and return-air paths complying with ASTM E84; testing by a qualified testing agency. Identify products with appropriate markings of applicable testing agency.

1. Flame-Spread Index: 25 or less.

2. Smoke-Developed Index: 50 or less.

E. DDC System Speed:

1. Response Time of Connected I/O:

- a. Update AI point values connected to DDC system at least every two seconds for use by DDC controllers. Points used globally to also comply with this requirement.
- b. Update BI point values connected to DDC system at least every two seconds for use by DDC controllers. Points used globally to also comply with this requirement.
- c. AO points connected to DDC system to begin to respond to controller output commands within two second(s). Global commands to also comply with this requirement.
- d. BO point values connected to DDC system to respond to controller output commands within two second(s). Global commands to also comply with this requirement.

2. Display of Connected I/O:

- a. Update and display analog point COV connected to DDC system at least every five seconds for use by operator.
- b. Update and display binary point COV connected to DDC system at least every five seconds for use by operator.
- c. Update and display alarms of analog and digital points connected to DDC system within 30 seconds of activation or change of state.
- d. Update graphic display refresh within eight seconds.
- e. Point change of values and alarms displayed from workstation to workstation when multiple operators are viewing from multiple workstations to not exceed graphic refresh rate indicated.

F. Network Bandwidth: Design each network of DDC system to include spare bandwidth with DDC system operating under normal and heavy load conditions indicated. Calculate bandwidth usage, and apply a safety factor to ensure that requirement is satisfied when subjected to testing under worst case conditions. Minimum spare bandwidth as follows:

1. Level 1 Networks: 20.
2. Level 2 Networks: 20.
3. Level 3 Networks: 20.

G. DDC System Data Storage:

1. Include capability to archive not less than 36 consecutive months of historical data for all I/O points connected to system, including alarms, event histories, transaction logs, trends, and other information indicated.
2. Local Storage:
 - a. Provide server with data storage indicated. Server(s) to use IT industry standard database platforms and be capable of functions described in "DDC Data Access" Paragraph.
3. Cloud Storage:

- a. Provide web browser interfaces to configure, upload, download, and manage data and to service plan with storage adequate to store all data for term indicated. Cloud storage uses IT industry standard database platforms and is capable of functions described in "DDC Data Access" Paragraph.

H. DDC Data Access:

1. When logged into the system, operator able to also interact with any DDC controllers connected to DDC system as required for functional operation of DDC system.
2. Use for application configuration; for archiving, reporting, and trending of data; for operator transaction archiving and reporting; for network information management; for alarm announcement; and for operator interface tasks and controls application management.

I. Future Expandability:

1. DDC system size is expandable to an ultimate capacity of at least 1.5 times total I/O points indicated.
2. Design and install system networks to achieve ultimate capacity with only addition of DDC controllers, I/O, and associated wiring and cable. Design and install initial network infrastructure to support ultimate capacity without having to remove and replace portions of network installation.
3. Operator interfaces installed initially do not require hardware and software additions and revisions for system when operating at ultimate capacity.

J. Input Point Values Displayed Accuracy: Meet following end-to-end overall system accuracy, including errors associated with meter, sensor, transmitter, lead wire or cable, and analog to digital conversion.

1. Energy:

- a. Thermal: Within 3 percent of reading.
- b. Electric Power: Within 1 percent of reading.
- c. Requirements indicated on Drawings for meters not supplied by utility.

2. Flow:

- a. Air: Within 2 percent of design flow rate.
- b. Air (Terminal Units): Within 10 percent of design flow rate.

3. Gas:

- a. Carbon Dioxide: Within 50 ppm.
- b. Carbon Monoxide: Within 5 percent of reading.
- c. Oxygen: Within 5 percent of reading.
- d. Refrigerant: Within 5 percent of reading.
- e. VOCs: Within 5 percent of reading.

4. Moisture (Relative Humidity):

- a. Air: Within 2 percent RH.
- b. Space: Within 2 percent RH.

- c. Outdoor: Within 2 percent RH.
- 5.Level: Within 5 percent of reading.
- 6.Pressure:
- a. Air, Ducts and Equipment: 0.5 percent of instrument range.
- 7.Speed: Within 5 percent of reading.
- 8.Temperature, Dew Point:
- a. Air: Within 0.5 deg F.
 - b. Space: Within 0.5 deg F.
 - c. Outdoor: Within 2 deg F.
- 9.Temperature, Dry Bulb:
- a. Air: Within 0.5 deg F.
 - b. Space: Within 0.5 deg F.
 - c. Outdoor: Within 1 deg F.
 - d. Temperature Difference: Within 0.25 deg F.
 - e. Other Temperatures Not Indicated: Within 0.5 deg F.
10. Temperature, Wet Bulb:
- a. Air: Within 0.5 deg F.
 - b. Space: Within 0.5 deg F.
 - c. Outdoor: Within 1 deg F.
11. Vibration: Within 5 percent of reading.
- K. Precision of I/O Reported Values: Values reported in database and displayed to have following precision:
- 1.Current:
- a. Milliampere: Nearest 1/100th of a milliampere.
 - b. Amperes: Nearest 1/10th of an ampere up to 100 A; nearest ampere for 100 A and more.
- 2.Energy:
- a. Electric Power:
 - 1) Rate (Watts): Nearest 1/10th of a watt through 1000 W.
 - 2) Rate (Kilowatts): Nearest 1/10th of a kilowatt through 1000 kW; nearest kilowatt above 1000 kW.
 - 3) Usage (Kilowatt-Hours): Nearest kilowatt through 10,000 kW; nearest 10 kW between 10,000 and 100,000 kW; nearest 100 kW for above 100,000 kW.
 - b. Thermal, Rate:

- 1) Heating: For British thermal units per hour, nearest British thermal unit per hour up to 1000 Btu/h; nearest 10 Btu/h between 1000 and 10,000 Btu/h; nearest 100 Btu/h for above 10,000 Btu/h. For MBh, round to nearest MBh up to 1000 MBh; nearest 10 MBh between 1000 and 10,000 MBh; nearest 100 MBh above 10,000 MBh.
- 2) Cooling: For tons, nearest ton up to 1000 tons; nearest 10 tons between 1000 and 10,000 tons; nearest 100 tons above 10,000 tons.

c. Thermal, Usage:

- 1) Heating: For British thermal unit, nearest British thermal unit up to 1000 Btu; nearest 10 Btu between 1000 and 10,000 Btu; nearest 100 Btu for above 10,000 Btu. For MBtu, round to nearest MBtu up to 1000 MBtu; nearest 10 MBtu between 1000 and 10,000 MBtu; nearest 100 MBtu above 10,000 MBtu.
- 2) Cooling: For ton-hours, nearest ton-hours up to 1000 ton-hours; nearest 10 ton-hours between 1000 and 10,000 ton-hours; nearest 100 tons above 10,000 tons.

3. Flow:

- a. Air: Nearest 1/10th of a cubic feet per minute through 100 cfm; nearest cubic feet per minute between 100 and 1000 cfm; nearest 10 cfm between 1000 and 10,000 cfm; nearest 100 cfm above 10,000 cfm.
- b. Water: Nearest 1/10th of a gallon per minute through 100 gpm; nearest gallon per minute between 100 and 1000 gpm; nearest 10 gpm between 1000 and 10,000 gpm; nearest 100 gpm above 10,000 gpm.

4. Moisture (Relative Humidity):

- a. Relative Humidity (Percentage): Nearest 1 percent.

5. Level: Nearest 1/100th of an inch through 10 inches; nearest 1/10 of an inch between 10 and 100 inches; nearest inch above 100 inches.

6. Speed:

- a. Rotation (rpm): Nearest 1 rpm.
- b. Velocity: Nearest 1/10th of feet per minute through 100 fpm; nearest feet per minute between 100 and 1000 fpm; nearest 10 fpm above 1000 fpm.

7. Position, Dampers and Valves (Percentage Open): Nearest 1 percent.

8. Pressure:

- a. Air, Ducts and Equipment: Nearest 1/10th of an inch water closet.
- b. Space: Nearest 1/100th of an inch water closet.
- c. Water: Nearest 1/10 of a pound per square inch gauge through 100 psig; nearest pound per square inch gauge above 100 psig.

9. Temperature:

- a. Air, Ducts and Equipment: Nearest 1/10th of a degree.

- b. Outdoor: Nearest degree.
 - c. Space: Nearest 1/10th of a degree.
- 10. Vibration: Nearest 1/10th of an inch per second.
 - 11. Voltage: Nearest 1/10 V up to 100 V; nearest volt above 100 V.
- L. Control Stability: Control variables indicated within the following limits:
- 1.Flow:
 - a. Air, Ducts and Equipment, except Terminal Units: Within 5 percent of design flow rate.
 - b. Air, Terminal Units: Within 10 percent of design flow rate.
 - c. Water: Within 5 percent of design flow rate.
 - 2.Gas:
 - a. Carbon Monoxide: Within 5 percent of reading.
 - 3.Moisture (Relative Humidity):
 - a. Air: Within 2 percent RH.
 - b. Space: Within 2 percent RH.
 - c. Outdoor: Within 2 percent RH.
 - 4.Level: Within 2 percent of reading.
 - 5.Pressure:
 - a. Air, Ducts and Equipment: 0.5 percent of instrument range.
 - b. Space: Within 0.5 percent of instrument range.
 - c. Water: Within 0.5 percent of instrument range.
 - 6.Temperature, Dew Point:
 - a. Air: Within 0.5 deg F.
 - b. Space: Within 0.5 deg F.
 - 7.Temperature, Dry Bulb:
 - a. Air: Within 0.5 deg F.
 - b. Space: Within 0.5 deg F.
 - 8.Temperature, Wet Bulb:
 - a. Air: Within 0.5 deg F.
 - b. Space: Within 0.5 deg F.
- M. Environmental Conditions for Controllers, Gateways, and Routers:
- 1.Products to operate without performance degradation under ambient environmental temperature, pressure, and humidity conditions encountered for installed location.

- a. If product alone cannot comply with requirement, install product in a protective enclosure that is isolated and protected from conditions impacting performance. Enclosure to be internally insulated, electrically heated, cooled, and ventilated as required by product and application.

N. Environmental Conditions for Instruments and Actuators:

1. Instruments and actuators to operate without performance degradation under the ambient environmental temperature, pressure, humidity, and vibration conditions specified and encountered for installed location.

- a. If instruments and actuators alone cannot comply with requirement, install instruments and actuators in protective enclosures that are isolated and protected from conditions impacting performance. Enclosure is internally insulated, electrically heated, cooled, and ventilated as required by instrument and application.

O. DDC System Reliability:

1. Design, install, and configure DDC controllers, gateways, routers, and to yield a MTBF of at least 40,000 hours, based on a confidence level of at least 90 percent. MTBF value includes any failure for any reason to any part of products indicated.
2. If required to comply with MTBF indicated, include DDC system and product redundancy to maintain DCC system, and associated systems and equipment being controlled, operational, and under automatic control.
3. See Drawings for critical systems and equipment that require a higher degree of DDC system redundancy than MTBF indicated.

P. Electric Power Quality:

1. Power-Line Surges:

- a. Protect susceptible DDC system products connected to ac power circuits from power-line surges to comply with requirements of IEEE C62.41.1 and IEEE C62.41.2.
- b. Do not use fuses for surge protection.
- c. Test protection in the normal mode and in the common mode, using the following two waveforms:
 - 1) 10-by-1000-microsecond waveform with a peak voltage of 1500 V and a peak current of 60 A.
 - 2) 8-by-20-microsecond waveform with a peak voltage of 1000 V and a peak current of 500 A.

2. Power Conditioning:

- a. Protect DDC system products connected to ac power circuits from irregularities and noise rejection. Characteristics of power-line conditioner are as follows:
 - 1) At 85 percent load, output voltage to not deviate by more than plus or minus 1 percent of nominal when input voltage fluctuates between minus 20 percent to plus 10 percent of nominal.

- 2) During load changes from zero to full load, output voltage to not deviate by more than 2 percent of nominal.
- 3) Accomplish full correction of load switching disturbances within five cycles, and 95 percent correction within two cycles of onset of disturbance.
- 4) Total harmonic distortion to not exceed 2 percent at full load.

3. Ground Fault: Protect products from ground fault by providing suitable grounding. Products to not fail due to ground fault condition.

Q. Backup Power Source:

1. Serve DDC system products that control HVAC systems and equipment served by a backup power source also from a backup power source.

R. UPS:

1. DDC system products powered by UPS units are to include the following:

- a. Servers.
- b. Gateways.
- c. DDC controllers, except application-specific controllers.
- d. Desktop workstations.

2. DDC system instruments and actuators powered by UPS units are to include the following:

- a. Instruments: Where indicated on Drawings; where associated with the following systems controlled by DDC system:
- b. Damper Actuators: Where indicated on Drawings; where associated with the following systems controlled by DDC system:
- c. Valve Actuators: Where indicated on Drawings; where associated with the following systems controlled by DDC system:

S. Continuity of Operation after Electric Power Interruption:

1. Equipment and associated factory-installed controls, field-installed controls, electrical equipment, and power supply connected to building normal and backup power systems are to automatically return equipment and associated controls to operating state occurring immediately before loss of normal power, without need for manual intervention by operator when power is restored either through backup power source or through normal power if restored before backup power is brought online.

2.5 PANEL-MOUNTED, MANUAL OVERRIDE SWITCHES

A. Manual Override of Control Dampers:

1. Include panel-mounted, two-position, selector switch for each automatic control damper being controlled by DDC controller.
2. Label each switch with damper designation served by switch.

3. Label switch positions to indicate either "Manual" or "Auto" control signal to damper.
4. With switch in "Auto" position, control signal to damper actuator with control loop output signal from DDC controller.
5. With switch in "Manual" position, control signal to damper actuator at panel with either an integral or a separate switch to include local control.
 - a. For Binary Control Dampers: Manual two-position switch with "Close" and "Open" switch positions indicated. With switch in "Close" position, close damper. With switch in "Open" position, open damper.
 - b. For Analog Control Dampers: A gradual switch with "Close" and "Open" switch limits indicated. Operator switches knob to adjust damper to any position from close to open.
6. DDC controller to monitor and report position of each manual override selector switch. With switch placed in "manual" position, DDC controller to signal an override condition to alert operator that damper is under manual, not automatic, control.
7. Configure manual override switches to allow operator to manually operate damper while at panel without DDC controller installed and operational.
8. Terminal equipment including VAV units, fan-coil units, and unit heaters do not require manual override unless otherwise indicated by sequence of operation.

B. Manual Override of Control Valves:

1. Include panel-mounted, two-position, selector switch for each automatic control valve being controlled by DDC controller.
2. Label each switch with valve designation served by switch.
3. Label switch positions to indicate either "Manual" or "Auto" control signal to valve.
4. With switch in "Auto" position, control signal to valve actuator with a control loop output signal from DDC controller.
5. With switch in "Manual" position, control signal to valve actuator at panel with either an integral or a separate switch to include local control.
 - a. For Binary Control Valves: Manual two-position switch with "Close" and "Open" switch positions indicated. With switch in "Close" position, close valve. With switch in "Open" position, open valve.
 - b. For Analog Control Valves: A gradual switch with "Open" and "Close" switch limits indicated. Operator rotates switch knob to adjust valve to any position from close to open.
6. DDC controller to monitor and report position of each manual override selector switch. With switch placed in "manual" position, DDC controller to signal an override condition to alert operator that valve is under manual, not automatic, control.
7. Configure manual override switches to allow operator to manually operate valve while at panel without DDC controller installed and operational.
8. Terminal equipment including VAV units, fan-coil units, and unit heaters do not require manual override unless otherwise indicated by sequence of operation.

2.6 SYSTEM ARCHITECTURE

- A. System architecture consisting of no more than two or three levels of LANs.

1. Level 2 LAN: Connect network controllers and operator workstations.
 2. Level 1 or Level 2 LAN: Connect Level 1 or Level 2 programmable application controllers to other programmable application controllers and to network controllers.
 3. Level 2 or Level 3 LAN: Connect Level 2 or Level 3 application-specific controllers to programmable application controllers and to network controllers.
- B. Minimum Data Transfer and Communication Speed:
1. LAN Connecting Operator Workstations and Network Controllers: 100 Mbps.
 2. LAN Connecting Programmable Application Controllers: 1000 kbps.
 3. LAN Connecting Application-Specific Controllers: 115,000 bps.
- C. Provide dedicated and separated DDC system LANs that are not shared with other building systems and tenant data and communication networks.
- D. Provide modular system architecture with inherent ability to expand to not less than 1.5 times system size indicated with no impact to performance indicated.
- E. Configure architecture to eliminate or minimize need to remove and replace existing network equipment for system expansion.
- F. Make number of LANs and associated communication transparent to operator. Configure all I/O points residing on any LAN to be capable of global sharing between all system LANs.
- G. Design system to eliminate dependence on any single device for system alarm reporting and control execution. Design each controller to operate independently by performing own control, alarm management, and historical data collection.
- H. Special Network Architecture Requirements:
1. Air-Handling Systems: For control applications of an air-handling system that consists of air-handling unit(s) and VAV terminal units, include a dedicated LAN of application-specific controllers serving VAV terminal units connected directly to controller that is controlling air-handling-system air-handling unit(s). Basically, create DDC system LAN that aligns with air-handling system being controlled.

2.7 DDC SYSTEM OPERATOR INTERFACES

- A. Operator Means of System Access: Operator able to access entire DDC system through any of multiple means including, but not limited to, the following:
1. Desktop and portable workstation with hardwired connection through LAN port.
 2. Portable operator terminal with hardwired connection through LAN port.
 3. Remote connection through web access.
- B. Make access to system, regardless of operator means used, transparent to operator.
- C. Network Ports: For hardwired connection of desktop or portable workstation. Network port easily accessible, properly protected, clearly labeled, and installed at the following locations:

1. Each mechanical equipment room.
2. Each outdoor on-grade yard and elevated platform with equipment connected to DDC system.
3. Each different roof level with roof-mounted equipment connected to DDC system.
4. Security system command center.
5. Fire-alarm system command center.

D. Critical Alarm Reporting:

1. Send operator-selected critical alarms to notify operator of critical alarms that require immediate attention.
2. Send alarm notification to multiple recipients that are assigned for each alarm.
3. Notify recipients by any or all means, including email, text message, and prerecorded phone message to mobile and landline phone numbers.

E. Simultaneous Operator Use: Capable of accommodating up to 10 simultaneous operators that are accessing DDC system through any of operator interfaces indicated.

2.8 NETWORKS

A. Acceptable networks for connecting workstations, mobile devices, and network controllers include the following:

1. ATA 878.1, ARCNET.
2. CTA-709.1-D.
3. IP.
4. ISO/IEC/IEEE 8802-3, Ethernet.

B. Acceptable networks for connecting programmable application controllers include the following:

1. ATA 878.1, ARCNET.
2. CTA-709.1-D.
3. IP.
4. ISO/IEC/IEEE 8802-3, Ethernet.

C. Acceptable networks for connecting application-specific controllers include the following:

1. ATA 878.1, ARCNET.
2. CTA-709.1-D.
3. TIA 485-A.
4. IP.
5. ISO/IEC/IEEE 8802-3, Ethernet.

2.9 NETWORK COMMUNICATION PROTOCOL

A. Use network communication protocol(s) that are open to Owner and available to other companies for use in making future modifications to DDC system.

B. ASHRAE 135 Protocol:

1. Use ASHRAE 135 communication protocol as sole and native protocol used throughout entire DDC system.
2. DDC system to not require use of gateways except to integrate HVAC equipment and other building systems and equipment; not required to use ASHRAE 135 communication protocol.
3. If used, gateways to connect to DDC system using ASHRAE 135 communication protocol and Project object properties and read/write services indicated by interoperability schedule.
4. Use operator workstations, controllers, and other network devices that are tested and listed by BTL.

C. Industry Standard Protocols:

1. Use any one or a combination of the following industry standard protocols for network communication while complying with other DDC system requirements indicated:
 - a. ASHRAE 135.
 - b. Modbus Application Protocol Specification V1.1b3.
2. Operator workstations and network controllers are to communicate through ASHRAE 135 protocol.
3. Provide portions of DDC system networks using ASHRAE 135 communication protocol as an open implementation of network devices complying with ASHRAE 135. Use network devices that are tested and listed by BTL.
4. Provide portions of DDC system networks using CTA-709.1-D communication protocol as an open implementation of LonWorks technology using CTA-709.1-D communication protocol and using LonMark SNVTs as defined in LonMark SNVT list exclusively for DDC system.
5. Provide portions of DDC system networks using Modbus Application Protocol Specification V1.1b3 communication protocol as an open implementation of network devices and technology complying with Modbus Application Protocol Specification V1.1b3.
6. Use gateways to connect networks and network devices with different protocols.

2.10 SERVERS

- A. Manufacturers: Subject to compliance with requirements, provide products by one of the following:
 1. Dell Technologies Inc.
 2. HP Inc.
 3. Lenovo Holding Co., Inc.; Lenovo Group Ltd.
- B. Description: x86-based permanently installed computer used for client-server computing.
- C. Power: Single power supply, minimum 300 W.
- D. Servers are to include the following:
 1. Full-feature backup server (server and backup minimum requirement).
 2. Software licenses.

3. Cable installation between server(s) and network.

E. Web Server:

1. If required to be separate, include web server hardware and software to match, except backup server is not required.
2. Firewalls between server web and networks.
3. Password protection for access to server from web server.
4. Cable installation between the server(s) and building Ethernet network.

F. Power each server through a UPS unit.

2.11 SYSTEM SOFTWARE

A. System Software Minimum Requirements:

1. Real-time multitasking and multiuser 32- or 64-bit operating system that allows concurrent multiple operator workstations operating and concurrent execution of multiple real-time programs and custom program development.
2. Operating system capable of operating DOS and Microsoft Windows applications.
3. Database management software to manage all data on an integrated and non-redundant basis. Additions and deletions to database are to be without detriment to existing data. Include cross linkages so no data required by a program can be deleted by an operator until that data have been deleted from respective programs.
4. Network communications software to manage and control multiple network communications to provide exchange of global information and execution of global programs.
5. Operator interface software to include day-to-day operator transaction processing, alarm and report handling, operator privilege level and data segregation control, custom programming, and online data modification capability.
6. Scheduling software to schedule centrally based time and event, temporary, and exception day programs.

B. Operator Interface Software:

1. Minimize operator training through use of English language prorating and English language point identification.
2. Minimize use of a typewriter-style keyboard through use of a pointing device similar to a mouse.
3. Make operator sign-off a manual operation or, if no keyboard or mouse activity takes place, an automatic sign-off.
4. Make automatic sign-off period programmable from one to 60 minutes in one-minute increments on a per operator basis.
5. Record operator sign-on and sign-off activity and send to printer.
6. Security Access:
 - a. Use password control for operator access to DDC system.
 - b. Assign an alphanumeric password (field assignable) to each operator.
 - c. Grant operators access to DDC system by entry of proper password.
 - d. Use same operator password regardless of which computer or other operator interface means are used.

- e. Automatically update additions or changes made to passwords.
- f. Assign each operator an access level to restrict access to data and functions the operator is capable of performing.
- g. Provide software with at least five access levels.
- h. Assign each menu item an access level so that a one-for-one correspondence between operator assigned access level(s) and menu item access level(s) is required to gain access to menu item.
- i. Display menu items to operator with those capable of access highlighted. Make menu and operator access level assignments online programmable and under password control.

7.Data Segregation:

- a. Include data segregation for control of specific data routed to a workstation, to an operator or to a specific output device, such as a printer.
- b. Include at least 32 segregation groups.
- c. Make segregation groups selectable such as "fire points," "fire points on second floor," "space temperature points," "HVAC points," and so on.
- d. Make points assignable to multiple segregation groups. Display and output of data to printer or monitor is to occur where there is a match of operator or peripheral segregation group assignment and point segregations.
- e. Make alarms displayed and printed at each peripheral to which segregation allows, but only those operators assigned to peripheral and having proper authorization level will be allowed to acknowledge alarms.
- f. Assign operators and peripherals to multiple segregation groups and make all assignments online programmable and under password control.

8.Operators able to perform commands including, but not limited to, the following:

- a. Start or stop selected equipment.
- b. Adjust set points.
- c. Add, modify, and delete time programming.
- d. Enable and disable process execution.
- e. Lock and unlock alarm reporting for each point.
- f. Enable and disable totalization for each point.
- g. Enable and disable trending for each point.
- h. Override control loop set points.
- i. Enter temporary override schedules.
- j. Define holiday schedules.
- k. Change time and date.
- l. Enter and modify analog alarm limits.
- m. Enter and modify analog warning limits.
- n. View limits.
- o. Enable and disable demand limiting.
- p. Enable and disable duty cycle.
- q. Display logic programming for each control sequence.

9.Reporting:

- a. Generated automatically and manually.
- b. Sent to displays, printers and disc files.

c. Types of Reporting:

- 1) General listing of points.
 - 2) List points currently in alarm.
 - 3) List of off-line points.
 - 4) List points currently in override status.
 - 5) List of disabled points.
 - 6) List points currently locked out.
 - 7) List of items defined in a "Follow-Up" file.
 - 8) List weekly schedules.
 - 9) List holiday programming.
 - 10) List of limits and deadbands.
10. Summaries: For specific points, for a logical point group, for an operator selected group(s), or for entire system without restriction due to hardware configuration.

C. Graphic Interface Software:

1. Include a full interactive graphical selection means of accessing and displaying system data to operator. Include at least five levels with the penetration path operator assignable (for example, site, building, floor, air-handling unit, and supply temperature loop). Native language descriptors assigned to menu items are to be operator defined and modifiable under password control.
2. Include a hierarchical-linked dynamic graphic operator interface for accessing and displaying system data and commanding and modifying equipment operation. Interface is to use a pointing device with pull-down or penetrating menus, color, and animation to facilitate operator understanding of system.
3. Include at least 10 levels of graphic penetration with the hierarchy operator assignable.
4. Make descriptors for graphics, points, alarms, and such modifiable through operator's workstation under password control.
5. Make graphic displays online user definable and modifiable using the hardware and software provided.
6. Make data displayed within a graphic assignable regardless of physical hardware address, communication, or point type.
7. Make graphics online programmable and under password control.
8. Make points assignable to multiple graphics where necessary to facilitate operator understanding of system operation.
9. Graphics to also contain software points.
10. Penetration within a graphic hierarchy is to display each graphic name as graphics are selected to facilitate operator understanding.
11. Provide a back-trace feature to permit operator to move upward in the hierarchy using a pointing device. Back trace to show all previous penetration levels. Include operator with option of showing each graphic full-screen size with back trace as horizontal header or by showing a "stack" of graphics, each with a back trace.
12. Display operator accessed data on the monitor.
13. Provide operator with ability to select further penetration using pointing device to click on a site, building, floor, area, equipment, and so on. Display defined and linked graphic below that selection.
14. Include operator with means to directly access graphics without going through penetration path.
15. Make dynamic data assignable to graphics.

16. Display points (physical and software) with dynamic data provided by DDC system with appropriate text descriptors, status or value, and engineering unit.
17. Use color, rotation, or other highly visible means, to denote status and alarm states. Make colors variable for each class of points, as chosen by operator.
18. Provide dynamic points with operator adjustable update rates on a per point basis from one second to over a minute.
19. For operators with appropriate privilege, command points directly from display using pointing device.
 - a. For an analog command point such as set point, display current conditions and limits so operator can position new set point using pointing device.
 - b. For a digital command point such as valve position, show valve in current state such as open or closed so operator could select alternative position using pointing device.
 - c. Include a keyboard equivalent for those operators with that preference.
20. Give operator ability to split or resize viewing screen into quadrants to show one graphic on one quadrant of screen and other graphics or spreadsheet, bar chart, word processing, curve plot, and other information on other quadrants on screen. This feature allows real-time monitoring of one part of system while displaying other parts of system or data to better facilitate overall system operation.
21. Help Features:
 - a. Online context-sensitive help utility to facilitate operator training and understanding.
 - b. Bridge to further explanation of selected keywords and contain text and graphics to clarify system operation.
 - 1) If help feature does not have ability to bridge on keywords for more information, provide a complete set of user manuals in an indexed word-processing program, which runs concurrently with operating system software.
 - c. Available for Every Menu Item:
 - 1) Index items for each system menu item.
22. Provide graphic generation software to allow operator ability to add, modify, or delete system graphic displays.
 - a. Include libraries of symbols depicting HVAC symbols such as fans, coils, filters, dampers, valves pumps, and electrical symbols similar to those indicated.
 - b. Use a pointing device in conjunction with a drawing program to allow operator to perform the following:
 - 1) Define background screens.
 - 2) Define connecting lines and curves.
 - 3) Locate, orient, and size descriptive text.
 - 4) Define and display colors for all elements.
 - 5) Establish correlation between symbols or text and associated system points or other displays.

D. Project-Specific Graphics: Graphics documentation including, but not limited to, the following:

1. Site plan showing each building, and additional site elements, which are being controlled or monitored by DDC system.
2. Plan for each building floor, including interstitial floors, and each roof level of each building, showing the following:
 - a. Room layouts with room identification and name.
 - b. Locations and identification of all monitored and controlled HVAC equipment and other equipment being monitored and controlled by DDC system.
 - c. Location and identification of each hardware point being controlled or monitored by DDC system.
3. Control schematic for each of following, including a graphic system schematic representation, similar to that indicated on Drawings, with point identification, set point and dynamic value indication, sequence of operation and control logic diagram.
4. Graphic display for each piece of equipment connected to DDC system through a data communications link. Include dynamic indication of all points associated with equipment.
5. DDC system network riser diagram that shows schematic layout for entire system including all networks and all controllers, gateways and other network devices.

E. Customizing Software:

1. Software to modify and tailor DDC system to specific and unique requirements of equipment installed, to programs implemented and to staffing and operational practices planned.
2. Online modification of DDC system configuration, program parameters, and database using menu selection and keyboard entry of data into preformatted display templates.
3. At a minimum, include the following modification capability:
 - a. Operator Assignment: Designation of operator passwords, access levels, point segregation, and auto sign-off.
 - b. Peripheral Assignment: Assignment of segregation groups and operators to consoles and printers, designation of backup workstations and printers, designation of workstation header points, and enabling and disabling of printout of operator changes.
 - c. System Configuration and Diagnostics: Communications and peripheral port assignments, DDC controller assignments to network, DDC controller enable and disable, assignment of command trace to points, and application programs and initiation of diagnostics.
 - d. System Text Addition and Change: English or native language descriptors for points, segregation groups and access levels and action messages for alarms, run time, and trouble condition.
 - e. Time and Schedule Change: Time and date set, time and occupancy schedules, exception and holiday schedules, and daylight-savings time schedules.
 - f. Point related change capability is to include the following:
 - 1) System and point enable and disable.
 - 2) Run-time enable and disable.
 - 3) Assignment of points to segregation groups, calibration tables, lockout, and run time and to a fixed I/O value.
 - 4) Assignment of alarm and warning limits.

g. Application program change capability is to include the following:

- 1) Enable and disable of software programs.
- 2) Programming changes.
- 3) Assignment of comfort limits, global points, time and event initiators, time and event schedules and enable and disable time and event programs.

4. Provide software to allow operator ability to add points, or groups of points, to DDC system and to link them to energy optimization and management programs. Make additions and modifications online programmable using operator workstations, downloaded to other network devices and entered into their databases. After verification of point additions and associated program operation, upload and record database on hard drive and disc for archived record.

5. Include high-level language programming software capability for implementation of custom DDC programs. Include a compiler, linker, and up- and down-load capability.

6. Include a library of DDC algorithms, intrinsic control operators, arithmetic, logic, and relational operators for implementation of control sequences. Also include, at a minimum, the following:

- a. Proportional control (P).
- b. Proportional plus integral (PI).
- c. Proportional plus integral plus derivative (PID).
- d. Adaptive and intelligent self-learning control.

- 1) Algorithm monitors loop response to output corrections and adjust loop response characteristics in accordance with time constant changes imposed.
- 2) Algorithm operates in a continuous self-learning manner and retains in memory a stored record of system dynamics so that on system shut down and restart, learning process starts from where it left off.

7. Fully implemented intrinsic control operators including sequence, reversing, ratio, time delay, time of day, highest select AO, lowest select AO, analog controlled digital output, analog control AO, and digitally controlled AO.

8. Logic operators such as "And," "Or," "Not," and others that are part of a standard set available with a high-level language.

9. Arithmetic operators such as "Add," "Subtract," "Multiply," "Divide," and others that are part of a standard set available with a high-level language.

10. Relational operators such as "Equal to," "Not Equal to," "Less Than," "Greater Than," and others that are part of a standard set available with a high-level language.

F. Alarm Handling Software:

1. Include alarm handling software to report all alarm conditions monitored and transmitted through DDC controllers, gateways and other network devices.

2. Include first in, first out handling of alarms in accordance with alarm priority ranking, with most critical alarms first, and with buffer storage in case of simultaneous and multiple alarms.

3. Make alarm handling active at all times to ensure that alarms are processed even if an operator is not currently signed on to DDC system.

4. Alarms display is to include the following:

- a. Indication of alarm condition such as "Abnormal Off," "Hi Alarm," and "Low Alarm."
 - b. "Analog Value" or "Status" group and point identification with native language point descriptor such as "Space Temperature, Building 110, 2nd Floor, Room 212."
 - c. Discrete per point alarm action message, such as "Call Maintenance Dept. Ext-5561."
 - d. Include extended message capability to allow assignment and printing of extended action messages. Capability is to be operator programmable and assignable on a per point basis.
5. Direct alarms to appropriate operator workstations, printers, and individual operators by privilege level and segregation assignments.
6. Send email alarm messages to designated operators.
7. Send email, page, text, and voice messages to designated operators for critical alarms.
8. Categorize and process alarms by class.
- a. Class 1:
 - 1) Associated with fire, security, and other extremely critical equipment monitoring functions; have alarm, trouble, return to normal, and acknowledge conditions printed and displayed.
 - 2) Unacknowledged alarms to be placed in unacknowledged alarm buffer.
 - 3) All conditions make an audible alarm sound and require individual acknowledgment to silence audible sound.
 - b. Class 2:
 - 1) Critical, but not life-safety related, and processed same as Class 1 alarms, except do not require individual acknowledgment.
 - 2) Acknowledgement may be through a multiple alarm acknowledgment.
 - c. Class 3:
 - 1) General alarms; printed, displayed, and placed in unacknowledged alarm buffer queues.
 - 2) Configure so each new alarm received makes an audible alarm sound that are silenced by "acknowledging" alarm or by pressing a "silence" key.
 - 3) Make acknowledgement of queued alarms either on an individual basis or through a multiple alarm acknowledgement.
 - 4) Print alarms returning to normal condition without an audible alarm sound or require acknowledgment.
 - d. Class 4:
 - 1) Routine maintenance or other types of warning alarms.
 - 2) Alarms to be printed only, with no display, no audible sound and no acknowledgment required.
9. Include an unacknowledged alarm indicator on display to alert operator that there are unacknowledged alarms in system. Operator able to acknowledge alarms on an individual basis or through a multiple alarm acknowledge key, depending on alarm class.

10. To ensure that no alarm records are lost, make it possible to assign a backup printer to accept alarms in case of failure of primary printer.
- G. Reports and Logs:
1. Include reporting software package that allows operator to select, modify, or create reports using DDC system I/O point data available.
 2. Setup each report so data content, format, interval, and date are operator definable.
 3. Sample and store report data on DDC controller, within storage limits of DDC controller, and then uploaded to archive on workstation for historical reporting.
 4. Make it possible for operators to obtain real-time logs of all I/O points by type or status, such as alarm, point lockout, or normal.
 5. Store reports and logs on workstations and servers hard drives in a format that is readily accessible by other standard software applications, including spreadsheets and word processing.
 6. Make reports and logs readily printable and set to be print either on operator command or at a specific time each day.
- H. Standard Reports: Provide standard DDC system reports with operator ability to customize reports later.
1. All I/O: With current status and values.
 2. Alarm: All current alarms, except those in alarm lockout.
 3. Disabled I/O: All I/O points that are disabled.
 4. Alarm Lockout I/O: All I/O points in alarm lockout, whether manual or automatic.
 5. Alarm Lockout I/O in Alarm: All I/O in alarm lockout that are currently in alarm.
 6. Logs:
 - a. Alarm history.
 - b. System messages.
 - c. System events.
 - d. Trends.
 - e. <Insert requirement>.
- I. Custom Reports: Operator able to easily define and prepare any system data into a daily, weekly, monthly, annual, or other historical report. Reports to include a title with time and date stamp.
- J. Tenant Override Reports: Prepare Project-specific reports.
1. Daily report showing total time in hours that each tenant has requested after-hours HVAC.
 2. Weekly report showing daily total time in hours that each tenant has requested after-hours HVAC.
 3. Monthly report showing daily total time in hours that each tenant has requested after-hours HVAC.
 4. Annual summary report that shows after-hours HVAC usage on a monthly basis.
- K. Utility Reports: Prepare Project-specific reports.
1. Electric Report:

- a. Include weekly report showing daily electrical consumption and peak electrical demand with time and date stamp for each meter.
- b. Include monthly report showing the daily electrical consumption and peak electrical demand with time and date stamp for each meter.
- c. Include annual report showing monthly electrical consumption and peak electrical demand with time and date stamp for each meter.
- d. For each weekly, monthly, and annual report, include sum total of submeters combined by load type, such as lighting, receptacles, and HVAC equipment showing daily electrical consumption and peak electrical demand.
- e. For each weekly, monthly, and annual report, include sum total of all submeters in building showing electrical consumption and peak electrical demand.

2. Service Water Report:

- a. Include weekly, monthly, and annual report showing daily service water consumption and peak service water demand with time and date stamp for each meter.
- b. For each weekly, monthly, and annual report, include sum total of submeters combined by load type, such as cooling tower makeup and irrigation showing daily service water consumption and peak service water demand.
- c. For each weekly, monthly, and annual report, include sum total of all submeters in building showing service water consumption and peak service water demand.

L. Energy Reports: Prepare Project-specific daily, weekly, monthly, and annual, annual and since-installed energy reports.

1. Prepare report for each purchased energy utility, indicating the following:

- a. Time being reported with beginning and end date, and time indicated.
- b. Consumption in units of measure commonly used to report specific utility consumption over time.
- c. Gross area served by utility.
- d. Consumption per unit area served using utility-specific unit of measure.
- e. Cost per utility unit.
- f. Utility cost per unit area.
- g. Convert all utilities to a common energy consumption unit of measure and report for each utility.
- h. Consumption per unit area using common unit of measure.

2. Prepare report for each renewable energy source, indicating the following:

- a. Time being reported with beginning and end date, and time indicated.
- b. Harvested energy in units of measure commonly used to report specific harvested energy consumption over time.
- c. Gross area served by renewable energy source.
- d. Harvested energy per unit area served using specific unit of measure.
- e. Cost per purchased utility unit displaced by renewable energy.
- f. Cost savings attributed to harvested energy source.
- g. Cost savings per unit area attributed to harvested energy.
- h. Convert all renewable energy sources to a common energy consumption unit of measure and report for each.
- i. Harvested energy per unit area using common unit of measure.

3. Prepare purchased energy utility report for each submetered area that indicates the following:

- a. Time being reported with beginning and end date, and time indicated.
- b. Gross area served.
- c. Energy consumption by energy utility type.
- d. Energy consumption per unit area by energy utility type.
- e. Total energy consumption of all utilities in common units of measure.
- f. Total energy consumption of all utilities in common units of measure per unit area.
- g. Unit energy cost by energy utility type.
- h. Energy cost by energy utility type.
- i. Energy cost per unit area by energy utility type.
- j. Total cost of all energy utilities.
- k. Total cost of all energy utilities per unit area.

4. Prepare Project total purchased energy utility report that combines all purchased energy utilities and all areas served. Project total energy report is to indicate the following:

- a. Time being reported with beginning and end date, and time indicated.
- b. Gross area served.
- c. Energy consumption by energy utility type.
- d. Energy consumption per unit area by energy utility type.
- e. Total energy consumption of all utilities in common units of measure.
- f. Total energy consumption of all utilities in common units of measure per unit area.
- g. Unit energy cost by energy utility type.
- h. Energy cost by energy utility type.
- i. Energy cost per unit area by energy utility type.
- j. Total cost of all energy utilities.
- k. Total cost of all energy utilities per unit area.

M. Weather Reports:

1. Include daily report showing the following:

- a. Daily minimum, maximum, and average outdoor dry-bulb temperature.
- b. Daily minimum, maximum, and average outdoor wet-bulb temperature.
- c. Daily minimum, maximum, and average outdoor dew point temperature.
- d. Number of heating degree-days for each day calculated from a base temperature of 55 deg F.
- e. Number of cooling degree-days for each day calculated from a base temperature of 65 deg F.
- f. Daily minimum, maximum, and average outdoor carbon dioxide level.
- g. Daily minimum, maximum, and average relative humidity.
- h. Daily minimum, maximum, and average barometric pressure.
- i. Daily minimum, maximum, and average wind speed and direction.

2. Include weekly report showing the following:

- a. Daily minimum, maximum, and average outdoor dry-bulb temperature.
- b. Daily minimum, maximum, and average outdoor wet-bulb temperature.
- c. Daily minimum, maximum, and average outdoor dew point temperature.

- d. Number of heating degree-days for each day calculated from a base temperature of 55 deg F.
- e. Number of cooling degree-days for each day calculated from a base temperature of 65 deg F.
- f. Weekly minimum, maximum, and average outdoor carbon dioxide level.
- g. Daily minimum, maximum, and average relative humidity.
- h. Daily minimum, maximum, and average barometric pressure.
- i. Daily minimum, maximum, and average wind speed and direction.

3. Include monthly report showing the following:

- a. Daily minimum, maximum, and average outdoor dry-bulb temperature.
- b. Daily minimum, maximum, and average outdoor wet-bulb temperature.
- c. Daily minimum, maximum, and average outdoor dew point temperature.
- d. Number of heating degree-days for each day calculated from a base temperature of 55 deg F.
- e. Number of cooling degree-days for each day calculated from a base temperature of 65 deg F.
- f. Monthly minimum, maximum, and average outdoor carbon dioxide level.
- g. Daily minimum, maximum, and average relative humidity.
- h. Daily minimum, maximum, and average barometric pressure.
- i. Daily minimum, maximum, and average wind speed and direction.

4. Include annual (12-month) report showing the following:

- a. Monthly minimum, maximum, and average outdoor dry-bulb temperature.
- b. Monthly minimum, maximum, and average outdoor wet-bulb temperature.
- c. Monthly minimum, maximum, and average outdoor dew point temperature.
- d. Number of heating degree-days for each month calculated from a base temperature of 55 deg F.
- e. Number of cooling degree-days for each month calculated from a base temperature of 65 deg F.
- f. Annual minimum, maximum, and average outdoor carbon dioxide level.
- g. Monthly minimum, maximum, and average relative humidity.
- h. Daily minimum, maximum, and average barometric pressure.
- i. Daily minimum, maximum, and average wind speed and direction.

N. Standard Trends:

1. Trend all I/O point present values, set points, and other parameters indicated for trending.
2. Associate trends into groups, and setup a trend report for each group.
3. Store trends within DDC controller and uploaded to hard drives automatically on reaching 75 percent of DDC controller buffer limit, or by operator request, or by archiving time schedule.
4. Preset trend intervals for each I/O point after review with Owner.
5. Make trend intervals operator selectable from 10 seconds up to 60 minutes. Make minimum number of consecutive trend values stored at one time 100 per variable.
6. When drive storage memory is full, overwrite oldest data with most recent data.
7. Make archived and real-time trend data available for viewing numerically and graphically by operators.

- O. Custom Trends: Operator-definable custom trend log for any I/O point in DDC system.
1. Include each trend with interval, start time, and stop time.
 2. Sample and store data on DDC controller, within reaching 75 percent storage limits of DDC controller, and then uploaded to archive on server hard drives.
 3. Make data retrievable for use in spreadsheets and standard database programs.
- P. Programming Software:
1. Include programming software to execute sequences of operation indicated.
 2. Include programming routines in simple and easy to follow logic with detailed text comments describing what the logic does and how it corresponds to sequence of operation.
 3. Programming Software: As follows:
 - a. Graphic Based: Use a library of function blocks made from preprogrammed code designed for DDC control systems.
 - 1) Assemble function blocks with interconnection lines that represent to control sequence in a flowchart.
 - 2) Make programming tools viewable in real time to show present values and logical results of each function block.
 - b. Menu Based: Done by entering parameters, definitions, conditions, requirements, and constraints.
 - c. Line by Line and Text Based: Programming is to declare variable types such as local, global, real, integer, and so on, at the beginning of the program. Use descriptive comments frequently to describe programming code.
 4. Include means for detecting programming errors and testing software control strategies with a simulation tool before implementing in actual control. Simulation tool may be inherent with programming software or as a separate product.
- Q. Database Management Software:
1. Where a separate SQL database is used for information storage, include database management software that separates database monitoring and managing functions by supporting multiple separate windows.
 2. Secure database access using standard SQL authentication including ability to access data for use outside of DDC system applications.
 3. Include database management function summarizing information on trend, alarm, event, and audit for the following database management actions:
 - a. Backup.
 - b. Purge.
 - c. Restore.
 4. Database management software supporting the following:
 - a. Statistics: Display database server information and trend, alarm, event, and audit information on database.

- b. Maintenance: Include method of purging records from trend, alarm, event, and audit databases by supporting separate screens for creating a backup before purging, selecting database, and allowing for retention of a selected number of day's data.
- c. Backup: Include means to create a database backup file and select a storage location.
- d. Restore: Include a restricted means of restoring a database by requiring operator to have proper security level.

5. Information of current database activity, including the following:

- a. Ready.
- b. Purging record from a database.
- c. Action failed.
- d. Refreshing statistics.
- e. Restoring database.
- f. Shrinking a database.
- g. Backing up a database.
- h. Resetting Internet information services.
- i. Starting network device manager.
- j. Shutting down the network device manager.
- k. Action successful.

6. Database management software monitoring functions is to continuously read database information once operator has logged on.

7. Include operator notification through on-screen pop-up display and email message when database value has exceeded a warning or alarm limit.

8. Monitoring settings window with the following Sections:

- a. Allow operator to set and review scan intervals and start times.
- b. Email: Allow operator to create and review email and phone text messages to be delivered when a warning or an alarm is generated.
- c. Warning: Allow operator to define warning limit parameters, set reminder frequency, and link email message.
- d. Alarm: Allow operator to define alarm limit parameters, set reminder frequency, and link email message.
- e. Database Login: Protect system from unauthorized database manipulation by creating a read access and a write access for each of trend, alarm, event, and audit databases as well as operator proper security access to restore a database.

9. Monitoring settings taskbar with following informational icons:

- a. Normal: Indicates by color and size, or other easily identifiable means, that all databases are within their limits.
- b. Warning: Indicates by color and size, or other easily identifiable means, that one or more databases have exceeded their warning limit.
- c. Alarm: Indicates by color and size, or other easily identifiable means, that one or more databases have exceeded their alarm limit.

2.12 ANALYTICS SOFTWARE

- A. Scope: Incorporate analytics software into DDC System:

- 1.Licensing, without Recurring Cost: No re-occurring cost for licensing and subscriptions.
- 2.Licensing: With or without re-occurring cost for licensing and subscriptions.
 - a. For products with re-occurring costs, provide incremental costs broken down over a 10-year operating period that begins at Final Acceptance.
 - b. Setup service agreements direct to Owner.
- 3.Purpose: Analyze energy and operational data to identify faults and opportunities for improved performance and reduced energy use.
- 4.Verification: Verify that HVAC systems and associated sequence of operations are executing as specified or as described on Drawings, through the analysis of energy and operational data, identification of faults showing where control sequences are not functioning as prescribed, and identification of opportunities for improved performance in the operation of systems.

B. Use during Project Life:

- 1.During Construction: Use for verification of performance during startup, commissioning, and final acceptance of DDC system.
- 2.During Warranty Period: Use for continuous operational tuning of DDC system and verification of operation and designed to identify warranty issues preemptively, thus reducing failures and potential down time.
- 3.After Warranty Period: Use to diagnose ongoing operational degradation and for Owner to perform continuous monitoring-based commissioning.

C. Minimum Features and Capabilities:

- 1.Operating Systems: Current version of Windows-based operating systems.
- 2.Time Series Database: Database technology, designed for efficient storage and analysis of large volumes of time series data, using tagging to model and describe data; supports an open-source tagging standard.
- 3.Data Import: Ability to accept and normalize data from a variety of sources including SQL compatible databases, CSV format files, XML format files or web services, and other EDI techniques. Once imported, software is to provide a unified data format to enable analytics algorithms to identify patterns across different data sets.
- 4.Open Interfaces: Open, REST-based APIs to enable integration with third-party software applications. Open APIs are to enable data to be entered/imported into database, exported from database, posting of analytic queries, and output of analytic results. APIs are to be fully documented and available as part of standard product.
- 5.Host: Local deployed on DDC system network.
- 6.Weather Data Service: Built-in worldwide weather service providing weather data including, but not limited to, the following:
 - a. Current temperature.
 - b. High temperature for the day.
 - c. Low temperature for the day.
 - d. Sunrise and sunset times.
 - e. Relative humidity.
 - f. Degree days (heating and cooling with adjustable balance point value).
 - g. Seven-day forecast.
 - h. Historical weather data extending back at least one year.

7. Email Notification: Automatic notification of detected issues via email including, but not limited to, the following:

- a. Immediate notification of detected issues.
- b. Daily digest or summary of detected issues.
- c. Ability to delineate which notifications are sent to which recipients down to the level of specifying individual issues sent to individual recipients.

D. Hardware Requirements:

1. Host on a server in a virtual environment complying with Owner's security requirements.
2. Comply with standard software and hardware profiles required by Owner.

E. Analytic Rules:

1. Custom Rule Development: Develop customized rules and algorithms tailored to operational needs and characteristics of individual facilities and needs of monitoring and verification project and fault-detection requirements of Project without depending on manufacturer for rule development. Provide tools for user development and full documentation.
2. Standard Analytic Functions: Library of standard analytic functions is to use these standard analytic functions as elements to build custom analytic rules for specific needs of individual facilities.
3. Existing library of not less than 200 standard analytic rules written for applications similar to those required for this Project.

F. Reporting:

1. Standard Views of Analytic Results: Standard views to present analytic results, automatically generated when issues are found by analytic rules including, but not limited to, the following:
 - a. Rules violations across a portfolio of sites, rules violations per site, including time, date, and duration of all violations.
 - b. Ability to assign cost relationships to rule logic to provide cost per violation.
 - c. Standard filters to enable operator to easily look at rule violations by site, data, and violation type for any selected date or date range.
 - d. Automatic calculation and presentation of Key Performance Indicators (KPIs) and to define custom KPIs as needed.

2. Custom Views of Analytic Results:

- a. Any standard system view is to be able to be saved as a custom report including its configuration criteria, e.g., time range, sites, rule violations, or other configuration options as applicable to standard system view.
- b. Created by making queries against the database and saving the query as a saved report executed by single mouse click.
- c. Export: Support report views export into CSV, Excel, XML, and HTML format, accomplished in a couple of mouse clicks.

G. Energy-Specific Reporting and Information Presentation Tools:

- 1.Greenhouse Gas Analysis: Energy/carbon dioxide relationships; easily changed and added without involvement of software manufacturer.
- 2.Energy Baseline: Quantify and define energy consumption and demand baselines (including weather normalization metrics) and compare actual and forecasted energy demand and consumption against those baselines.
- 3.Benchmarking: Multisite benchmarking to compare energy consumption and demand profiles and baselines across all buildings within Owner's portfolio.
- 4.Forecasting: Forecast near-future loads by using historic trends and forecasted weather data.
- 5.Financial Analysis: Calculate costs based on energy consumption and demand and energy costs and associate costs with any faults discovered by any analytic function and perform model- or tariff-based calculations to determine costs.
- 6.Tracking of Key Performance Indicators: Definition and tracking of user-defined key performance indicators/operational metrics. Examples include energy demand and consumption normalized for area and weather, peak demand, and consumption shown with minimum and maximum ranges across any user-selectable period.
- 7.Correlation of Energy Use with Equipment Operation: Automatically present views showing correlation between energy demand and consumption and operation of loads associated with that usage. Include the following:
 - a. All submeters and virtual meters.
 - b. Weather data as a selectable item.

H. Implementation:

- 1.Apply analytic rules to all HVAC systems and equipment monitored and controlled by DDC system. To extent available, use a subset of rules in existing rules library.
- 2.Implement rules to aid in determining proper operation of any HVAC system with a programmed sequence of operation.
- 3.Generate reports to aid in verification of proper operation during initial system startup and commissioning to supplement (not replace) commissioning agent reports.
- 4.Prepare quarterly reports summarizing faults detected and KPIs, including recommended corrective action.

I. Training:

- 1.Train Owner sufficiently to use software without need for external support.

2.13 MAINTENANCE MANAGEMENT SOFTWARE

A. Scope:

- 1.Include complete and functional software-driven maintenance management system to perform scheduling of preventive maintenance and generation of work orders, for mechanical and electrical equipment and systems, and other equipment and systems indicated.
- 2.Automatically generate work orders from alarm conditions, run time, and calendar time. For each work order generated, list parts, tools, and craftspeople and define task to be performed.
- 3.Use work orders generated to schedule a repair or preventive maintenance routine.
- 4.Use work orders to track completion of work, parts used, and total cost of repair.

5. Include a database inventory tracking system to automatically update inventory database to show quantity of tools, repair parts, and expendables used for a work order.
6. Print work orders and preventive maintenance schedules on a printer assigned solely to maintenance management function.

B. Additional Hardware Requirements:

1. Maintenance management software is to not require additional hardware, except for an additional printer that is dedicated to maintenance management.

C. Integration: Integrate maintenance management software into DDC system.

D. System Features and Architecture

1. The controls system shall be web based, capable of integrating multiple building functions including equipment supervision and control, alarm management, energy management and historical data collection.
2. HVAC controls system contractor shall provide a fully integrated system, UL listed, incorporating direct digital control for energy management, equipment monitoring and control.
3. Building systems which require an emergency generator shall have a control system with UPS for all affected control panels.
4. The installer shall have at least 10 years of experience and be approved by the manufacturer for both installation and maintenance of building systems and equipment.
5. There shall be only one Ethernet connection per Network Engine to the university wide area network. The Ethernet connection shall not be located in NC State telecommunication rooms.
6. The sequence of operations for the building shall be available on the graphical webpage for the building systems, either through a link to a HTML page or a PDF.
7. In buildings and spaces requiring strict individual room humidity and/or air quality control, a multiple point air quality monitoring system shall be provided.

E. Software Requirements:

1. From main menu of maintenance management system, use selection of icons to penetrate to individual functions described below.
2. Work Orders:
 - a. Automatically generate work orders initiated from alarm conditions, accumulated run time, or calendar time. Work orders generated are to specify a particular task to be accomplished including labor, material, and tools needed to accomplish work.
 - b. Include at least two of the following types of work orders:
 - 1) Corrective and Emergency Maintenance: Generate for a specific job or repair for emergency, breakdown, or scheduled work.
 - 2) Preventive Maintenance: Use on a periodic basis to generate preventive maintenance work orders.

c. Include the following functions:

- 1) Work Order Tracking: Perform every function related to processing work orders including creating, approving and initiating work orders, checking their status history, and closing or reworking them when appropriate.
- 2) Work Requests: Report any problems that require corrective maintenance activity generated by dispatchers and those people designated to request work orders.
- 3) Quick Reporting: Report work done on an open work order or a small job.
- 4) Work Manager: Specify type of labor to be applied to a specific work order at specific times. Include capability to dispatch one or more laborers to top-priority jobs on as-needed basis and to interrupt work in progress to reassign labor to higher priority tasks.

d. Reports:

- 1) Daily Maintenance Schedule by Supervisor: List a schedule of open work orders for a specified date by supervisor.
- 2) Equipment Cost Roll-up Report: Include a roll-up of equipment costs incurred since the date the report was last run.
- 3) Delinquent Work Order Report: List open work orders whose target completion date is earlier than the date the report is run.
- 4) Employee Job Assignments: List labor codes that have job assignments for specified date.
- 5) Daily Work Order Assignment: List work orders that have labor assignments for specified date.
- 6) Estimated versus Actual Work Order Costs: List a cost summary of outstanding work orders.
- 7) Open Work Orders Report: List open work orders for locations and equipment.

3.Inventory:

- a. Include an inventory tracking system to keep track of stocked, non-stocked, and special-order items.
- b. Link inventory tracking to database and when items are consumed, as noted on a work order issued by system, and automatically update inventory of stocked items.
- c. Include the following functions:
 - 1) Inventory Control: Enter, display, and update information on each inventory item. Allow viewing of master inventory records that are independent of storeroom locations or item/location records. Include a screen that lists inventory transactions that move items in or out of inventory or from one storeroom location to another. Minimum information tracked is to include the following:
 - a) Vendors supply items.
 - b) Item balances, including the bin and lot level for each storeroom location.
 - c) Alternative items.

- 2) Issues and Transfers: Issue stock directly from inventory, with or without a work order. When transfer of stock from one location to another location occurs, provide appropriate adjustments in stock balance record. Include a trace record of stock transfers from one storeroom to another.
- 3) Item Assembly Structures: Include modeling of equipment with inventory items and building of equipment and location hierarchies.
- 4) Metered Material Usage:
 - a) Track usage by a piece of equipment.
 - b) Record against a standing work order for a selected piece of equipment.
 - c) Include a material usage transaction for each item of material used and provide as an input to calculation for per unit material consumption report for a piece of equipment.

d. Reports:

- 1) Inventory Analysis Report: List for a given storeroom location, inventory items analysis information that allows quick identification of which inventory items represent greatest monetary investment for dollar value and rate of turnover.
- 2) Inventory Cycle Count Report: List for a specified storeroom, inventory items that are due to be cycle-counted, based on cycle-count frequency and last count date.
- 3) Economic Order Quantity Report: For a given storeroom location, display optimum economic ordering quantity for items in selected results set.
- 4) Inventory Pick Report: A pick list, by work order for items needed to be pulled from a designated storeroom's inventory for work orders having a target start date of specified date.
- 5) Suggested Order Report: List inventory items in selected results set that are due to be recorded, for a specified storeroom location, based on the following calculation: Suggest a reorder if current balance minus reserve quantity plus on-order quantity is less than reorder point.
- 6) Reorder Point Report: List selected set of items and optimum minimum level to have in stock based on demand, lead delivery time, and a reserve safety stock.
- 7) Inventory Valuation Report: Gives an accounting of cost of current inventory, for inventory records in a designated storeroom location.
- 8) Item Order Status: Lists items on order.
- 9) List of Expired Items: Lists expired lot items in a storeroom. Report is to include item number, description, expiration date, bin number, lot number, manufacturer lot number, and quantity of expired items in that lot and bin.
- 10) Item Availability at All Locations: Lists alternative storeroom locations for selected items.
- 11) Where Used Report: List equipment on which item is recorded as being used.

4. Equipment:

- a. Include equipment and location records; establish relationships between equipment, between locations, and between equipment and locations; track maintenance costs; and enter and review meter readings.
- b. Include the following functions:

- 1) Equipment: Store equipment numbers and corresponding information including equipment class, location, vendor, up/down status, and maintenance costs for each piece of equipment. Include building of equipment assemblies. Provide equipment assemblies hierarchical ordering for arrangement of buildings, departments, equipment, and sub-assemblies.
- 2) Operating Locations: Facilitate creation of records for operating locations of equipment, and track equipment that is used in multiple locations. In addition, allow hierarchical organization of equipment operating in facility by means of grouping equipment locations into areas of responsibility.
- 3) Failure Codes: Develop and display failure hierarchies to acquire an accurate history of types of failures that affect equipment and operating locations.
- 4) Condition Monitoring: Display time-related or limit measurements recorded for a piece of equipment. Generate work orders from this screen and to take immediate action on problem conditions.

c. Reports:

- 1) Availability Statistic by Location: List equipment availability by location over a user-specified period.
- 2) Equipment Failure Summary: List total number of failures by problem code for a piece of equipment for specified period.
- 3) Detailed Equipment Failure Report by Equipment: List of failure reports for the current piece of equipment for specified period.
- 4) Equipment Hierarchy Report: List of equipment.
- 5) Equipment History Graphs: Include a graphical report in histogram format that displays equipment breakdown history over a specified period.
- 6) Equipment Measurement Report: Tabular listing and description of each measurement point for a piece of equipment and history of measurements taken for that point.
- 7) Maintenance Cost by Equipment: List of transactions costs for elected equipment in the specified date range.
- 8) Failure Count by Equipment: Graphically report number of failures for each piece of equipment showing number of failures for each piece of equipment over a specified period, occurrence of each problem code within set of failures, and failures by problem code.
- 9) Failure Analysis Graphs: Graphically report number of failures for each piece of equipment over a specified period, number of occurrences of each problem code within set of failures, and failures by problem code.
- 10) Failure Code Hierarchy Report: List of failure codes in each level of failure hierarchy.
- 11) Location Failure Summary: A summary for each selected location of failures reported and any hierarchy level locations for specified period.
- 12) Failure Summary by Location: A summary of failures for selected location and their subordinate locations that are part of hierarchical system.
- 13) Detailed Failure Report by Location: List all failures for selected location and its subordinate locations that are part of hierarchical system.
- 14) Maintenance Cost by System: List of total costs reported in a given date range for locations in selected hierarchical system.
- 15) Location Hierarchy Report: Lists member locations of hierarchical system displayed in hierarchical fashion.

5. Purchasing:

- a. Include preparation and generation of purchase requisitions and purchase orders; to report receipt of both items and services, match invoices with purchase orders and receipts and define and convert foreign currencies.
- b. Include the following functions:
 - 1) Purchase Requisition: Create and process purchase requisitions for items and services.
 - 2) Purchase Orders: Create and process purchase orders for items and services from scratch or from purchase requisitions. Record receipts of items and services.
 - 3) Invoices: Include functionality to match purchase orders with invoices and receipts. It is also possible to match a service receipt to an invoice. Project for entering of an invoice for bills that do not require purchase orders or receipts.
 - 4) Currency Management: Define currencies and specify exchange rates. Include preparation of purchase requisitions and purchase orders in currency of vendor while tracking costs in systems base currency.
- c. Reports:
 - 1) Invoice Approval Report: Include an approval form for entered invoices.
 - 2) Inventory Receipts Register: List purchase orders and inventory received for user-specified time frame.
 - 3) Direct Purchase Back-Order Report: List of items ordered as a direct purchase not received by required delivery date.
 - 4) Standard Purchase Order: A printing of primary purchase order with vendors shipping information, and items purchased.
 - 5) Purchase Order Status Report: List of purchase orders whose status has changed during a certain period.
 - 6) Standard Purchase Requisition: A printing of primary purchase requisition, including vendor name and shipping information.

6. Job Plans:

- a. Include creation of a detailed description of work to be performed by work order. Job plan is to contain operations, procedures and list of estimated material, labor, and tools required for work.

7. Labor:

- a. Store information on employees, contractors, and crafts and include the following functions:
 - 1) Labor: Create, modify, and view employee records. Employee records are to contain pay rate, overtime worked, overtime refused, special skills, and certifications.
 - 2) Crafts: Create, modify, and view craftspeople records.
 - 3) Labor Reporting: Report labor usage by employee or craft externally from work orders module.

b. Reports:

- 1) Employee Attendance Analysis: List of planned attendance, actual attendance, and vacation and sick time in hours as a percentage of planned attendance for selected employees for specified period.
- 2) Labor Productivity Analysis: List of actual labor hours by labor report category showing each by percentage.
- 3) Labor Availability versus Commitments by Crafts: A graphical report that details available labor hours versus committed work order hours by craft and day.

8. Calendars:

- a. Establish calendar records indicating working time for equipment, location, craft, and labor records.

9. Resources:

- a. Include entry and retrieval of data associated with resources required to maintain facility and to include the following functions:
 - 1) Companies: Establish and update data on vendors and other companies.
 - 2) Tools: Create and maintain information on the tools used on jobs. Make information contained within this module available to job plans and work orders.
 - 3) Service Contracts: Specify information on service contracts with vendors or manufacturers.

10. Custom Applications:

- a. Include creation of customized database tables and application screens that supplement functions specified.

11. Setup:

- a. Include configuration of database, security, and setup applications.
- b. Perform the following functions:
 - 1) Reports and Other Applications: Register reports and other applications for use within system.
 - 2) Documents: Enter, track, and link information from Drawings to equipment and inventory items.
 - 3) Chart of Accounts: Add or modify accounts; set up financial periods; enter inventory accounts, company accounts, and resource recovery accounts; and define tax codes and rates.
 - 4) Signature Security: Establish each user's access rights to modules, applications, screens, and options.
 - 5) Database Configuration: Customize database, including adjusting field lengths and modifying data types.
 - 6) Application Setup: Change position of icons and menu items on the main menu screen.

- 7) Application Launching: Allow for connecting of third-party applications to data fields and push buttons.

12. Utilities:

- a. Include utilities module that allows system administrator to customize system and to maintain database.
- b. Include the following functions:
 - 1) Interactive SQL: Include access to database for database management functions of import/export and backup.
 - 2) Edit Windows: Display a dialog box to customize an application.
 - 3) Archive Data: Remove records from database and store them for future reference.

F. Documentation:

1. Include complete documentation for system consisting of a User Manual and Systems Administrator Guide.
2. Describe how to use each application module and screen with step-by-step instructions detailing entry and retrieval of data for functions specified.
3. Include a step-by-step description of how each report is defined and retrieved.
4. Bind documentation and clearly title it indicating volume number and use.

2.14 OFFICE APPLICATION SOFTWARE

- A. Manufacturers: Subject to compliance with requirements, provide products by one of the following:
 1. Microsoft Corporation.
- B. Include current version of office application software at time of Final Acceptance.
- C. Office application software package to include multiple separate applications and use a common platform for all applications.
 1. Database.
 2. Email.
 3. Presentation.
 4. Publishing.
 5. Spreadsheet.
 6. Word processing.

2.15 ASHRAE 135 GATEWAYS

- A. Include BACnet communication ports, whenever available as an equipment OEM standard option, for integration via a single communication cable.

- B. Include gateways to connect BACnet to legacy systems where indicated, existing non-BACnet devices, and existing non-BACnet DDC-controlled equipment.
- C. Include with each gateway an interoperability schedule showing each point or event on legacy side that BACnet "client" will read, and each parameter that BACnet network will write to. Describe this interoperability of BACnet services, or BIBBs, defined in ASHRAE 135, Annex K.
- D. Gateway Minimum Requirements:
 - 1. Read and view all readable object properties on non-BACnet network to BACnet network, and vice versa, where applicable.
 - 2. Write to all writable object properties on non-BACnet network from BACnet network, and vice versa, where applicable.
 - 3. Include single-pass (only one protocol to BACnet without intermediary protocols) translation from non-BACnet protocol to BACnet, and vice versa.
 - 4. Comply with requirements of Data Sharing Read Property, Data Sharing Write Property, Device Management Dynamic Device Binding-B, and Device Management Communication Control BIBBs in accordance with ASHRAE 135.
 - 5. Hardware, software, software licenses, and configuration tools for operator-to-gateway communications.
 - 6. Backup programming and parameters on CD media with ability to modify, download, backup, and restore gateway configuration.

2.16 ASHRAE 135 PROTOCOL ANALYZER

- A. Analyzer and required cables and fittings for connection to ASHRAE 135 network.
- B. Include the following minimum capabilities:
 - 1. Capture and store to a file data traffic on all network levels.
 - 2. Measure bandwidth usage.
 - 3. Filtering options with ability to ignore select traffic.

2.17 CTA-709.1-D NETWORK HARDWARE

- A. Routers:
 - 1. Network routers, including routers configured as repeaters, are to comply with requirements of CTA-709.1-D and include connection between two or more CTA-709.3 TP/FT-10 channels or between two or more CTA-709.3 TP/FT-10 channels and a TP/XF-1250 channel.
 - 2. IP Routers:
 - a. Perform layer three routing of CTA-709.1-D packets over an IP network in accordance with CTA-852-C.
 - b. Include appropriate connection to IP network and connections to CTA-709.3 TP/FT-10 or TP/XF-1250 network.

- c. Support the Dynamic Host Configuration Protocol for IP configuration and use of an CTA-852-C Configuration Server (for CTA-852-C configuration), but do not rely on these services for configuration.
- d. Capable of manual configuration via a console RS-232 port.

B. Gateways:

- 1. Perform bidirectional protocol translation from one non-CTA-709.1-D protocol to CTA-709.1-D.
- 2. Incorporate a network connection to TP/FT-10 network in accordance with CTA-709.3 and a connection for non-CTA-709.1-D network.

2.18 DDC CONTROLLERS

- A. DDC Controllers (stand-alone) shall be microprocessor-based with a minimum word size of 16 bits. They shall be multi-tasking, multi-user, real-time digital control processors consisting of modular hardware with plug-in enclosed processors, communication controllers, power supplies and input/output point modules.
- B. Control of the mechanical systems shall be performed by a field programmable microprocessor-based DDC, which incorporates closed loop control algorithms, all necessary energy management functions.
- C. Each unit shall, at a minimum, be capable of performing the following energy management functions:
 - 1. Start/stop optimization
 - 2. Time of day scheduling
 - 3. Enthalpy economizer control
 - 4. Supply air reset
 - 5. Event initiated programs
 - 6. Night setback
- D. Each DDC shall be capable of performing all specified control functions in a completely independent manner. Additionally, DDCs shall be capable of being networked for single point programming and for the sharing of information between panels. Including, but not limited to, sensor values, calculated point values, control set-points, tuning parameters, and control instructions.
- E. Each DDC microprocessor shall include its own microcomputer controller, power supply, input/output modules, termination modules, battery, and spare AC outlet. The battery shall be continuously charged and be capable of supporting all memory for a minimum of 72 hours. Upon restoration of system power, the control unit shall resume full operation without operator intervention.
- F. DDC system consisting of a combination of network controllers, programmable application controllers, and application-specific controllers to satisfy performance requirements indicated.
- G. DDC controllers to perform monitoring, control, energy optimization, and other requirements indicated.

- H. DDC controllers are to use a multitasking, multiuser, real-time digital control microprocessor with a distributed network database and intelligence.
- I. Each DDC controller is capable of full and complete operation as a completely independent unit and as a part of DDC system wide distributed network.
- J. Environment Requirements:
1. Controller hardware suitable for anticipated ambient conditions.
 2. Controllers located in conditioned space rated for operation at 32 to 120 deg F.
 3. Controllers located outdoors rated for operation at 40 to 150 deg F.
- K. Power and Noise Immunity:
1. Operate controller at 90 to 110 percent of nominal voltage rating and perform an orderly shutdown below 80 percent of nominal voltage.
 2. Protect against electrical noise of 5 to 120 Hz and from keyed radios with up to 5 W of power located within 36 inches of enclosure.
- L. DDC Controller Spare Processing Capacity:
1. Include spare processing memory for each controller. RAM, PROM, or EEPROM will implement requirements indicated with the following spare memory:
 - a. Network Controllers: 60 percent.
 - b. Programmable Application Controllers: Not less than 70 percent.
 - c. Application-Specific Controllers: Not less than 80 percent.
 2. Memory for DDC controller's operating system and database are to include the following:
 - a. Monitoring and control.
 - b. Energy management, operation, and optimization applications.
 - c. Alarm management.
 - d. Historical trend data of all connected I/O points.
 - e. Maintenance applications.
 - f. Operator interfaces.
 - g. Monitoring of manual overrides.
- M. DDC Controller Spare I/O Point Capacity: Include spare I/O point capacity for each controller as follows:
1. Network Controllers:
 - a. 10 percent of each AI, AO, BI, and BO point connected to controller.
 - b. Minimum Spare I/O Points per Controller:
 - 1) AIs: Two.
 - 2) AOs: Two.
 - 3) BIs: Three.
 - 4) BOs: Three.
 - 5) Option to provide universal I/O to meet spare requirements.

2. Programmable Application Controllers:

- a. 10 percent of each AI, AO, BI, and BO point connected to controller.
- b. Minimum Spare I/O Points per Controller:
 - 1) AIs: Two.
 - 2) AOs: Two.
 - 3) BIs: Three.
 - 4) BOs: Three.
 - 5) Option to provide universal I/O to meet spare requirements.

3. Application-Specific Controllers:

- a. 10 percent of each AI, AO, BI, and BO point connected to controller.
- b. Minimum Spare I/O Points per Controller:
 - 1) AIs: One.
 - 2) AOs: One.
 - 3) BIs: One.
 - 4) BOs: One.
 - 5) Option to provide universal I/O to meet spare requirements.

N. Maintenance and Support: Include the following features to facilitate maintenance and support:

1. Mount microprocessor components on circuit cards for ease of removal and replacement.
2. Means to quickly and easily disconnect controller from network.
3. Means to quickly and easily access connect to field test equipment.
4. Visual indication that controller electric power is on, of communication fault or trouble, and that controller is receiving and sending signals to network.

O. General Requirements for CTA-709.1-D DDC Controllers:

1. LonMark certified.
2. Distinguishable and accessible switch, button, or pin, when pressed is to broadcast its 48-bit Node ID and Program ID over network.
3. TP/FT-10 transceiver in accordance with CTA-709.3 and connections for TP/FT-10 control network wiring.
4. TP/XF-1250 transceiver in accordance with CTA-709.3 and connections for TP/XF-1250 control network wiring.
5. Communicate using CTA-709.1-D protocol.
6. Controllers configured into subnets, as required, to comply with performance requirements indicated.
7. Network communication through LNS network management and database standard for CTA-709.1-D network devices.
8. Locally powered, not powered through network connection.
9. Functionality required to support applications indicated including, but not limited to, the following:

- a. I/Os indicated and as required to support sequence of operation and application in which it is used. SNVTs to have meaningful names identifying the value represented by SNVT. Unless SNVT of an appropriate engineering type is unavailable, all network variables to be of SNVT with engineering units appropriate to value the variable represents.
 - b. Configurable through SCPTs defined in LonMark SCPT List, operator-defined UCPTs, network configuration inputs (NCIs) of SNVT type defined in LonMark SNVT List, NCIs of an operator-defined network variable type, or hardware settings on controller itself for all settings and parameters used by application in which it is used.
10. Programmable controllers comply with "LonMark Interoperability Guidelines" and have LonMark certification.

P. I/O Point Interface:

1. Connect hardwired I/O points to network, programmable application, and application-specific controllers.
2. Protect I/O points so shorting of point to itself, to another point, or to ground will not damage controller.
3. Protect I/O points from voltage up to 24 V of any duration so that contact will not damage controller.
4. AIs:

- a. Include monitoring of low-voltage (0 to 10 V dc), current (4 to 20 mA) and resistance signals from thermistor and RTD sensors.
- b. Compatible with, and field configurable to, sensor and transmitters installed.
- c. Perform analog-to-digital (A-to-D) conversion with a minimum resolution of 12 bits or better to comply with accuracy requirements indicated.
- d. Signal conditioning including transient rejection for each AI.
- e. Capable of being individually calibrated for zero and span.
- f. Incorporate common-mode noise rejection of at least 50 dB from 0 to 100 Hz for differential inputs, and normal-mode noise rejection of at least 20 dB at 60 Hz from a source impedance of 10000 ohms.
- g. External conversion resistors are not permitted.

5. AOs:

- a. Perform analog-to-digital (A-to-D) conversion with a minimum resolution of 12 bits or better to comply with accuracy requirements indicated.
- b. Output signals range of 4 to 20 mA dc or 0 to 10 V dc as required to include proper control of output device.
- c. Capable of being individually calibrated for zero and span.
- d. Drift is to be not greater than 0.4 percent of range per year.
- e. External conversion resistors are not permitted.

6. BIs:

- a. Accept contact closures and ignore transients of less than 5 ms duration.
- b. Isolate and protect against an applied steady-state voltage of up to 180 V ac peak.

- c. Include a wetting current of at least 12 mA to be compatible with commonly available control devices and protected against effects of contact bounce and noise.
- d. Sense "dry contact" closure without external power (other than that provided by controller) being applied.
- e. Pulse accumulation input points complying with all requirements of BIs and accept up to 10 pulses per second for pulse accumulation. Include buffer to totalize pulses. Pulse accumulator is to accept rates of at least 20 pulses per second. Reset the totalized value to zero on operator's command.

7.BOs:

- a. Include relay contact closures or triac outputs for momentary and maintained operation of output devices.
 - 1) Relay contact closures to have a minimum duration of 0.1 second and at least 180 V of isolation.
 - 2) Include electromagnetic interference suppression on all output lines to limit transients to non-damaging levels.
 - 3) Minimum contact rating to be 1 A at 24 V ac.
 - 4) Triac outputs to have at least 180 V of isolation and minimum contact rating of 1 A at 24 V ac.
- b. Include BOs with two-state operation or a pulsed low-voltage signal for pulse-width modulation control.
- c. BOs to be selectable for either normally open or normally closed operation.
- d. Include tristate outputs (two coordinated BOs) for control of three-point, floating-type electronic actuators without feedback.
- e. Limit use of three-point floating devices to VAV terminal unit control applications, and other applications indicated on Drawings. Control algorithms to operate actuator to one end of its stroke once every 24 hours for verification of operator tracking.

2.19 NETWORK CONTROLLERS

A. General:

1. Include adequate number of controllers to achieve performance indicated.
2. Provide one or more independent, standalone, microprocessor-based network controllers to manage global strategies indicated.
3. Include enough memory to support its operating system, database, and programming requirements with spare memory indicated.
4. Share data between networked controllers and other network devices.
5. Operating system of controller to manage I/O communication signals to allow distributed controllers to share real and virtual object information and allow for central monitoring and alarms.
6. Include network controllers with a real-time clock.
7. Controller to continually check status of its processor and memory circuits. If an abnormal operation is detected, controller is to assume a predetermined failure mode and generate an alarm notification.
8. Make controllers fully programmable.

B. Communication:

1. Network controllers communicate with other devices on DDC system Level 1 network.
2. Network controller to also perform routing if connected to network of programmable application controllers and application-specific controllers.

C. Operator Interface:

1. Local Keypad and Display:

- a. Equip controller with local keypad and digital display for interrogating and editing data.
- b. Use of keypad and display requires a security password.

D. Serviceability:

1. Equip controller with diagnostic LEDs or other form of local visual indication of power, communication, and processor.
2. Connect wiring and cable connections to field-removable, modular terminal strips or to a termination card connected by a ribbon cable.
3. Maintain Basic Input Output System (BIOS) and programming information in event of power loss for at least 72 hours.

2.20 PROGRAMMABLE APPLICATION CONTROLLERS

A. General:

1. Include adequate number of controllers to achieve performance indicated.
2. Provide enough memory to support its operating system, database, and programming requirements with spare memory indicated.
3. Share data between networked controllers and other network devices.
4. Include controller with operating system to manage I/O communication signals to allow distributed controllers to share real and virtual object information and allow for central monitoring and alarms.
5. Include controllers that perform scheduling with a real-time clock.
6. Controller is to continually check status of its processor and memory circuits. If an abnormal operation is detected, controller assumes a predetermined failure mode and generates an alarm notification.
7. Fully programmable.

B. Communication:

1. Programmable application controllers are to communicate with other devices on network.

C. Operator Interface:

1. Local Keypad and Display:

- a. Equip controller with local keypad and digital display for interrogating and editing data.
- b. Protect use of keypad and display by security password.

D. Serviceability:

1. Equip controller with diagnostic LEDs or other form of local visual indication of power, communication, and processor.
2. Connect wiring and cable connections to field-removable, modular terminal strips or to a termination card connected by a ribbon cable.
3. Maintain BIOS and programming information in event of power loss for at least 72 hours.

2.21 APPLICATION-SPECIFIC CONTROLLERS

A. Description: Microprocessor-based controllers, which through hardware or firmware design are dedicated to control a specific piece of equipment or system. Controllers are not fully user-programmable but are configurable and customizable for operation of equipment they are designed to control.

1. Capable of standalone operation and continued control functions without being connected to network.
2. Share data between networked controllers and other network devices.

B. Communication: Application-specific controllers are to communicate with other application-specific controllers and devices on network, and to programmable application controllers and network controllers.

C. Serviceability:

1. Equip controller with diagnostic LEDs or other form of local visual indication of power, communication, and processor.
2. Connect wiring and cable connections to field-removable, modular terminal strips or to a termination card connected by a ribbon cable.
3. Use nonvolatile memory and maintain all BIOS and programming information in event of power loss.

2.22 CONTROLLER SOFTWARE

A. General:

1. Software applications are to reside and operate in controllers. Edit applications through operator workstations.
2. Identify I/O points by up to 30-character point name and up to 16-character point descriptor. Use same names throughout, including at operator workstations.
3. Execute control functions within controllers using DDC algorithms.
4. Configure controllers to use stored default values to ensure fail-safe operation. Use default values when there is a failure of a connected input instrument or loss of communication of a global point value.

B. Security:

1. Secure operator access using individual security passwords and user names.

2. Passwords restrict operator to points, applications, and system functions as assigned by system manager.
 3. Record operator log-on and log-off attempts.
 4. Protect from unauthorized use by automatically logging off after last keystroke. Make the delay time operator-definable.
- C. Scheduling: Include capability to schedule each point or group of points in system. Each schedule is to consist of the following:
1. Weekly Schedules:
 - a. Include separate schedules for each day of week.
 - b. Each schedule should include capability for start, stop, optimal start, optimal stop, and night economizer.
 - c. Each schedule may consist of up to 10 events.
 - d. When a group of objects are scheduled together, include capability to adjust start and stop times for each member.
 2. Exception Schedules:
 - a. Include ability for operator to designate any day of the year as an exception schedule.
 - b. Exception schedules may be defined up to a year in advance. Once an exception schedule is executed, it will be discarded and replaced by regular schedule for that day of week.
 3. Holiday Schedules:
 - a. Include capability for operator to define up to 99 special or holiday schedules.
 - b. Place schedules on scheduling calendar with ability to repeated each year.
 - c. Operator able to define length of each holiday period.
- D. System Coordination:
1. Include standard application for proper coordination of equipment.
 2. Include operator with a method of grouping together equipment based on function and location.
 3. Include groups that may be for use in scheduling and other applications.
- E. Binary Alarms:
1. Set each binary point to alarm based on operator-specified state.
 2. Include capability to automatically and manually disable alarming.
- F. Analog Alarms:
1. Provide each analog object with both high and low alarm limits.
 2. Include capability to automatically and manually disable alarming.
- G. Alarm Reporting:
1. Include ability for operators to determine action to be taken in event of an alarm.

- 2.Route alarms to appropriate operator workstations based on time and other conditions.
- 3.Include ability for alarms to start programs, print, be logged in event logs, generate custom messages, and display graphics.

H. Remote Communication:

- 1.Include ability for system to notify operators by phone message, text message, and email in event of an alarm.

I. Electric Power Demand Limiting:

- 1.Monitor building or other operator-defined electric power consumption from signals connected to electric power meter or from a watt transducer or current transformer.
- 2.Predict probable power demand such that action can be taken to prevent exceeding demand limit. When demand prediction exceeds demand limit, action will be taken to reduce loads in a predetermined manner. When demand prediction indicates demand limit will not be exceeded, action will be taken to restore loads in a predetermined manner.
- 3.Accomplish demand reduction by the following means:
 - a. Reset air-handling-unit supply temperature set points.
 - b. Reset space temperature set points.
 - c. De-energize equipment based on priority.
- 4.Base demand-limiting parameters, frequency of calculations, time intervals, and other relevant variables on the means by which electric power service provider computes demand charges.
- 5.Include demand-limiting prediction and control for any individual meter monitored by system or for total of any combination of meters.
- 6.Include means operator to make the following changes online:
 - a. Addition and deletion of loads controlled.
 - b. Changes in demand intervals.
 - c. Changes in demand limit for meter(s).
 - d. Maximum shutoff time for equipment.
 - e. Minimum shutoff time for equipment.
 - f. Select rotational or sequential shedding and restoring.
 - g. Shed and restore priority.
- 7.Include the following information and reports, to be available on an hourly, daily, weekly, monthly, and annual basis:
 - a. Total electric consumption.
 - b. Peak demand.
 - c. Date and time of peak demand.
 - d. Daily peak demand.

J. Maintenance Management: Monitor equipment status and generate maintenance messages based on operator-designated run-time, starts, and calendar date limits.

K. Sequencing: Include application software based on sequences of operation indicated to properly sequence and other applicable HVAC equipment.

L. Control Loops:

1. Support any of the following control loops, as applicable to control required:

- a. Two-position (on/off, open/close, slow/fast) control.
- b. Proportional control.
- c. Proportional plus integral (PI) control.
- d. Proportional plus integral plus derivative (PID) control.
 - 1) Include PID algorithms with direct or reverse action and anti-windup.
 - 2) Algorithm to calculate a time-varying analog value used to position an output or stage a series of outputs.
 - 3) Make controlled variable, set point, and PID gains operator-selectable.
- e. Adaptive (automatic tuning).

M. Staggered Start: Prevent all controlled equipment from simultaneously restarting after a power outage. Make the order which equipment (or groups of equipment) is started, along with the time delay between starts, operator-selectable.

N. Energy Calculations:

1. Include software to allow instantaneous power or flow rates to be accumulated and converted to energy usage data.
2. Include algorithm that calculates a sliding-window average (rolling average). Make algorithm flexible to allow window intervals to be operator specified (such as 15, 30, or 60 minutes).
3. Include algorithm that calculates a fixed-window average. Use a digital input signal to define start of window period (such as signal from utility meter) to synchronize fixed-window average with that used by utility.

O. Anti-Short Cycling:

1. Protect BO points from short cycling.
2. Feature to allow minimum on-time and off-time to be selected.

P. On and Off Control with Differential:

1. Include algorithm that allows BO to be cycled based on a controlled variable and set point.
2. Use direct- or reverse-acting algorithm and incorporate an adjustable differential.

Q. Run-Time Totalization:

1. Include software to totalize run-times for all BI and BO points.
2. Assign a high run-time alarm, if required, by operator.

2.23 ENCLOSURES

A. General:

1. House each controller and associated control accessories in single enclosure. Enclosure is to serve as central tie-in point for control devices such as switches, transmitters, transducers, power supplies, and transformers.
2. Do not house more than one controller in single enclosure.
3. Include enclosure door with key locking mechanism. Key locks alike for all enclosures and include one pair of keys per enclosure.
4. Equip doors of enclosures housing controllers and components with analog or digital displays with windows to allow visual observation of displays without opening enclosure door.
5. Individual, wall-mounted, single-door enclosures maximum of 36 inches wide and 48 inches high.
6. Individual, wall-mounted, double-door enclosures maximum of 60 inches wide and 36 inches high.
7. Freestanding enclosures maximum of 48 inches wide and 72 inches high.
8. Include wall-mounted enclosures with brackets suitable for mounting enclosures to wall or freestanding support stand as indicated.
9. Supply each enclosure with complete set of as-built schematics, tubing, and wiring diagrams and product literature located in pocket on inside of door. For enclosures with windows, include pocket on bottom of enclosure.

B. Internal Arrangement:

1. Arrange internal layout of enclosure to group and protect electric, and electronic components associated with controller, but not an integral part of controller.
2. Arrange layout to group similar products together.
3. Include a barrier between line-voltage and low-voltage electrical and electronic products.
4. Factory or shop install products, tubing, cabling, and wiring complying with requirements and standards indicated.
5. Terminate field cable and wire using heavy-duty terminal blocks.
6. Include spare terminals, equal to not less than 10 percent of used terminals.
7. Include spade lugs for stranded cable and wire.
8. Install maximum of two wires on each side of terminal.
9. Include enclosure field electric power supply with toggle-type switch located at entrance inside enclosure to disconnect power.
10. Include enclosure with line-voltage nominal 20 A GFCI duplex receptacle for service and testing tools. Wire receptacle on hot side of enclosure disconnect switch and include with 5 A circuit breaker.
11. Mount products within enclosure on removable internal panel(s).
12. Include products mounted in enclosures with engraved, laminated phenolic nameplates (black letters on a white background). Nameplates are to have at least 1/4-inch- high lettering.
13. Route tubing cable and wire located inside enclosure within a raceway with continuous removable cover.
14. Label each end of cable, wire, and tubing in enclosure following an approved identification system that extends from field I/O connection and all intermediate connections throughout length to controller connection.
15. Size enclosure internal panel to include at least 15 percent spare area on face of panel.

C. Environmental Requirements:

1. Evaluate temperature and humidity requirements of each product to be installed within each enclosure.

2. Calculate enclosure internal operating temperature considering heat dissipation of all products installed within enclosure and ambient effects (solar, conduction, and wind) on enclosure.
3. Where required by application, include temperature-controlled electrical heat to maintain inside of enclosure above minimum operating temperature of product with most stringent requirement.
4. Where required by application, include temperature-controlled ventilation fans with filtered louver(s) to maintain inside of enclosure below maximum operating temperature of product with most stringent requirement.
5. Include temperature-controlled cooling within the enclosure for applications where ventilation fans cannot maintain inside temperature of enclosure below maximum operating temperature of product with most stringent requirement.
6. Where required by application, include humidity-controlled electric dehumidifier or cooling to maintain inside of enclosure below maximum relative humidity of product with most stringent requirement and to prevent surface condensation within enclosure.

D. Wall-Mounted, NEMA 250, Type 1:

1. Manufacturers: Subject to compliance with requirements, provide products by one of the following:
 - a. B-Line; a division of Eaton, Electrical Sector.
 - b. Hammond Mfg. Co. Inc.
 - c. Hoffman; brand of nVent Electrical plc.
 - d. Saginaw Control and Engineering.
2. NRTL listed in accordance with UL 50 or UL 50E.
3. Construct enclosure of steel, not less than the following:
 - a. Enclosure Size Less Than 24 Inches (600 mm): 0.053 inch or 0.067 inch thick.
 - b. Enclosure Size 24 Inches (600 mm) and Larger: 0.067 inch or 0.093 inch thick.
4. Finish enclosure inside and out with polyester powder coating that is electrostatically applied and then baked to bond to substrate.
 - a. Exterior Color: Manufacturer's standard.
 - b. Interior Color: Manufacturer's standard.
5. Hinged door full size of front face of enclosure and supported using the following:
 - a. Enclosures Sizes Less Than 36 Inches (900 mm) Tall: Multiple butt hinges.
 - b. Enclosures Sizes 36 Inches (900 mm) Tall and Larger: Continuous piano hinges.
6. Removable internal panel with white or gray polyester powder coating that is electrostatically applied and then baked to bond to substrate.
 - a. Size Less Than 24 Inches (600 mm): Solid or perforated] steel, 0.053 inch thick.
 - b. Size 24 Inches (600 mm) and Larger: Solid aluminum, 0.10 inch or steel, 0.093 inch thick.
7. Internal panel mounting hardware, grounding hardware, and sealing washers.

8. Grounding stud on enclosure body.
9. Thermoplastic pocket on inside of door for record Drawings and Product Data.

E. Wall-Mounted, NEMA 250, Types 4 and 12:

1. Manufacturers: Subject to compliance with requirements, provide products by one of the following:
 - a. B-Line; a division of Eaton, Electrical Sector.
 - b. Hammond Mfg. Co. Inc.
 - c. Hoffman; brand of nVent Electrical plc.
 - d. Saginaw Control and Engineering.
2. NRTL listed in accordance with UL 508A.
3. Seam and joints are continuously welded and ground smooth.
4. Where recessed enclosures are indicated, include enclosures with face flange for flush mounting.
5. Externally formed body flange around perimeter of enclosure face for continuous perimeter seamless gasket door seal.
6. Single-door enclosure sizes up to 60 inches tall by 36 inches wide.
7. Double-door enclosure sizes up to 36 inches tall by 60 inches wide.
8. Construct enclosure of steel, not less than the following:
 - a. Size Less Than 24 Inches (600 mm): 0.053 inch or 0.067 inch thick.
 - b. Size 24 Inches (600 mm) and Larger: 0.067 inch thick.
9. Finish enclosure with polyester powder coating that is electrostatically applied and then baked to bond to substrate.
 - a. Exterior Color: Manufacturer's standard.
 - b. Interior Color: Manufacturer's standard.
10. Corner-formed door, full size of enclosure face, supported using multiple concealed hinges with easily removable hinge pins.
 - a. Sizes through 24 Inches (600 mm) Tall: Two hinges.
 - b. Sizes between 24 Inches (600 mm) through 48 Inches (1200 mm) Tall: Three hinges.
 - c. Sizes Larger Than 48 Inches (1200 mm) Tall: Four hinges.
11. Double-door enclosures with overlapping door design to include unobstructed full-width access.
 - a. Single-door enclosures 48 inches and taller, and all double-door enclosures, with three-point (top, middle and bottom) latch system.
12. Removable internal panel with white or gray polyester powder coating that is electrostatically applied and then baked to bond to substrate.
 - a. Size Less Than 24 Inches (600 mm): Solid or perforated steel, 0.053 inch thick.
 - b. Size 24 Inches (600 mm) and Larger: Solid aluminum, 0.10 inch or steel, 0.093 inch thick.

13. Internal panel mounting studs with hardware, grounding hardware, and sealing washers.
14. Grounding stud on enclosure body.
15. Thermoplastic pocket on inside of door for record Drawings and Product Data.

F. Wall-Mounted, NEMA 250, Type 4X-SS:

- 1.Manufacturers: Subject to compliance with requirements, provide products by one of the following:
 - a. Crouse-Hinds; brand of Eaton, Electrical Sector.
 - b. Hammond Mfg. Co. Inc.
 - c. Hoffman; brand of nVent Electrical plc.
 - d. Saginaw Control and Engineering.
- 2.NRTL listed in accordance with UL 508A.
- 3.Seams and joints are continuously welded and ground smooth.
- 4.Externally formed body flange around perimeter of enclosure face for continuous perimeter seamless gasket door seal.
- 5.Construct enclosure of Type 304 or Type 316L stainless steel, not less than the following:
 - a. Size Less Than 24 Inches (600 mm): 0.053 inch thick.
 - b. Size 24 Inches (600 mm) and Larger: 0.067 inch thick.
- 6.Outside body and door of enclosure with brushed No. 4 finish.
- 7.Corner-formed door, full size of enclosure face, supported using multiple concealed hinges with easily removable hinge pins.
 - a. Sizes through 24 Inches (600 mm) Tall: Two hinges.
 - b. Sizes between 24 Inches (600 mm) through 48 Inches (1200 mm) Tall: Three hinges.
 - c. Sizes Larger Than 48 Inches (1200 mm) Tall: Four hinges.
- 8.Corner-formed door, full size of enclosure face, supported using continuous piano hinge full length of door.
- 9.Doors fitted with three-point (top, middle, and bottom) latch system with single, heavy-duty, liquidtight, Type 304 or Type 316L stainless steel handle with integral locking mechanism.
10. Removable internal panel of 0.093-inch stainless steel.
11. Internal panel mounting studs and hardware, grounding hardware, and sealing washers.
12. Install corrosion-resistant polyester vent drain in a stainless steel sleeve at bottom of enclosure.
13. Include enclosure with stainless steel mounting brackets.

G. Freestanding, NEMA 250, Type 1:

- 1.Manufacturers: Subject to compliance with requirements, provide products by one of the following:
 - a. B-Line; a division of Eaton, Electrical Sector.
 - b. Hammond Mfg. Co. Inc.
 - c. Hoffman; brand of nVent Electrical plc.
 - d. Saginaw Control and Engineering.

- 2.NRTL listed in accordance with UL 508A.
- 3.Seams and joints are continuously welded and ground smooth.
- 4.Externally formed body flange around perimeter of enclosure face.
- 5.Single-door enclosure sizes up to 84 inches tall by 36 inches wide.
- 6.Double-door enclosure sizes up to 84 inches tall by 72 inches wide.
- 7.Construct enclosure of steel, not less than 0.067 inch thick.
- 8.Finish enclosure with polyester powder coating that is electrostatically applied and then baked to bond to substrate.
 - a. Exterior Color: Manufacturer's standard.
 - b. Interior Color: Manufacturer's standard.
- 9.Corner-formed flush door, full size of enclosure face, supported using four concealed hinges with easily removable hinge pins.
10. Double-door enclosures with overlapping door design to include unobstructed full-width access.
11. Doors with three-point (top, middle, and bottom) latch system with single heavy-duty handle and integral locking mechanism.
12. Removable back covers.
13. Removable solid steel internal panel, 0.093 inch thick, with white or gray polyester powder coating that is electrostatically applied and then baked to bond to substrate.
14. Internal panel mounting studs with hardware, grounding hardware, and sealing washers.
15. Grounding stud on enclosure body.
16. Thermoplastic pocket on inside of door for record Drawings and Product Data.
17. Nominal 4-inch- tall integral lifting base, not less than 0.123 inch thick, with predrilled holes for attachment to mounting surface.
18. Equip each top end of enclosure with lifting tabs, not less than 0.172 inch thick, or not less than two lifting eyes.
19. Internal rack-mount shelves and angles, as required by application.

H. Freestanding, NEMA 250, Types 4 and 12:

- 1.Manufacturers: Subject to compliance with requirements, provide products by one of the following:
 - a. B-Line; a division of Eaton, Electrical Sector.
 - b. Hammond Mfg. Co. Inc.
 - c. Hoffman; brand of nVent Electrical plc.
 - d. Saginaw Control and Engineering.
- 2.NRTL listed in accordance with UL 508A.
- 3.Seams and joints are continuously welded and ground smooth.
- 4.Externally formed body flange around perimeter of enclosure face.
- 5.Type 12 Enclosure Sizes:
 - a. Single-door enclosure sizes up to 90 inches tall by 36 inches wide.
 - b. Double-door enclosure sizes up to 90 inches tall by 72 inches wide.
- 6.Type 4 Enclosure Sizes:
 - a. Single-door enclosure sizes up to 72 inches tall by 36 inches wide.

- b. Double-door enclosure sizes larger than 36 inches wide.
7. Construct enclosure of steel, not less than 0.093 inch thick.
 8. Finish enclosure with polyester powder coating that is electrostatically applied and then baked to bond to substrate.
 - a. Exterior Color: Manufacturer's standard.
 - b. Interior Color: Manufacturer's standard.
 9. Corner-formed door with continuous perimeter oil-resistant gasket supported using continuous piano hinge full length of door.
 10. Doors fitted with three-point (top, middle, and bottom) latch system with latching rod rollers and single, heavy-duty, oiltight handle with integral locking mechanism.
 11. Removable solid steel internal panel, 0.093 inch thick, with white or gray polyester powder coating that is electrostatically applied and then baked to bond to substrate.
 12. Internal panel mounting studs with hardware, grounding hardware, and sealing washers.
 13. Grounding stud on enclosure body.
 14. Thermoplastic pocket on inside of door for record Drawings and Product Data.
 15. Equip top of enclosure with no fewer than two lifting eyes.
 16. Internal rack-mount shelves and angles, as required by application.
- I. Freestanding, NEMA 250, Type 4X-SS:
1. Manufacturers: Subject to compliance with requirements, provide products by one of the following:
 - a. Crouse-Hinds; brand of Eaton, Electrical Sector.
 - b. Hammond Mfg. Co. Inc.
 - c. Hoffman; brand of nVent Electrical plc.
 - d. Saginaw Control and Engineering.
 2. NRTL listed in accordance with UL 508A.
 3. Seams and joints are continuously welded and ground smooth.
 4. Externally formed body flange around perimeter of enclosure face for continuous perimeter seamless gasket door seal.
 5. Construct enclosure of Type 304 or Type 316L stainless steel, not less than the following:
 - a. Size Less Than 24 Inches (600 mm): 0.053 inch thick.
 - b. Size 24 Inches (600 mm) and Larger: 0.067 inch thick.
 6. Outside enclosure and door of enclosure with brushed No. 4 finish.
 7. Doors:
 - a. Single-door enclosure sizes up to 36 inches wide.
 - b. Double-door enclosure sizes larger than 36 inches wide.
 - c. Corner-formed door(s) with continuous perimeter oil-resistant gasket, full size of enclosure face, supported using continuous piano hinge full length of door.
 - d. Doors fitted with three-point (top, middle, and bottom) latch system with single, heavy-duty, liquidtight, Type 304 or Type 316L stainless steel handle with integral locking mechanism.

8. Removable internal panel of 0.093-inch stainless steel.
9. Internal panel mounting studs and hardware, grounding hardware, and sealing washers.
10. Install corrosion-resistant polyester vent drain in a stainless steel sleeve at bottom of enclosure.
11. Include enclosure with stainless steel mounting brackets.
12. Thermoplastic pocket on inside of door for record Drawings and Product Data.
13. Equip top of enclosure with no fewer than two lifting eyes.
14. Internal rack-mount shelves and angles, as required by application.

J. Accessories:

1. Electric Heater:

- a. Aluminum housing with brushed finish.
- b. Thermostatic control with adjustable set point from 0 to 100 deg F.
- c. Capacity: 100, 200, 400, and 800 W, as required by application.
- d. Fan draws cool air from bottom of enclosure and passes air across thermostat and heating elements before being released into enclosure cavity. Heated air is discharged through the top of heater.

2. Ventilation Fans, Filtered Intake, and Exhaust Grilles:

- a. Number and size of fans, filters, and grilles, as required by application.
- b. Compact cooling fans engineered for 50,000 hours of continuous operation without lubrication or service.
- c. Fans capable of being installed on any surface and in any position within enclosure for spot cooling or air circulation.
- d. Thermostatic control with adjustable set point from 32 to 140 deg F.
- e. Airflow Capacity at Zero Pressure:
 - 1) 4-Inch (100-mm) Fan: 100 cfm.
 - 2) 6-Inch (150-mm) Fan: 240 cfm.
 - 3) 10-Inch (250-mm) Fan: 560 cfm.
- f. Maximum operating temperature of 158 deg F.
- g. 4-inch fan thermally protected and provided with permanently lubricated ball-bearings.
- h. 6- and 10-inch fans with ball-bearing construction and split capacitor motors thermally protected to avoid premature failure.
- i. Dynamically balanced impellers molded from polycarbonate material.
- j. Fan furnished with power cord and polarized plug for power connection.
- k. Fan brackets, finger guards, and mounting hardware provided with fans to complete installation.
- l. Removable Intake and Exhaust Grilles: ABS plastic or stainless steel, of size to match fan size and suitable for NEMA 250, Types 1 and 12 enclosures.
- m. Filters for NEMA 250, Type 1 Enclosures: Washable foam or aluminum, of size to match intake grille.
- n. Filters for NEMA 250, Type 12 Enclosures: Disposable, of size to match intake grille.

3. Air Conditioner:

- a. Electric-powered, self-contained, air-conditioning unit specially designed for electrical enclosures to maintain temperature inside enclosure below ambient temperature outside enclosure.
- b. Thermostatic control with adjustable set point from 60 to 120 deg F.
- c. Enclosure side or top mounting with unit capacity, as required by application.
- d. Designed for closed-loop cooling with continuous operation in ambient environments up to 125 deg F.
- e. HFC refrigerant.
- f. Reusable and washable air filter.
- g. High-performance, industrial-grade, and high-efficiency fans.
- h. Furnished with power cord and polarized plug for power connection.
- i. Condensate management system with base pan side drain.
- j. Mounting hardware, gaskets, mounting template, and instruction manual furnished with unit.
- k. Outdoor units equipped with head pressure control for low ambient operation, compressor heater, coated condenser coil, and thermostat.

4. Thermoelectric Humidifier:

- a. ABS plastic enclosure.
- b. Capacity of 8 oz. of water per 24 hours.
- c. Built-in drain captures moisture and plastic hose directs moisture to outside enclosure through a drain.
- d. Controlled to maintain enclosure relative humidity at adjustable set point.
- e. Unit power supply is internally wired to enclosure electrical power source.

5. Framed Fixed Window Kit for NEMA 250, Types 4, 4X, and 12 Enclosures:

- a. 0.25-inch- thick, scratch-resistant acrylic or polycarbonate window mounted in a metal frame matching adjacent door material.
- b. Enclosure types, except NEMA 250 Type 1, to have continuous gasket material around perimeter of window and frame to provide watertight seal.
- c. Window kit to be factory or shop installed before shipment to Project.

6. Frameless Fixed Window Kit for NEMA 250, Type 1 Enclosures:

- a. 0.125-inch- thick, polycarbonate window mounted in enclosure door material.
- b. Window attached to door with screw fasteners and continuous strip of high-strength, double-sided tape around window perimeter.
- c. Window kit is factory or shop installed before shipment to Project.

7. Frame Fixed or Hinged Window Kit for NEMA 250, Types 1 and 12 Enclosures:

- a. 0.25-inch- thick, scratch-resistant acrylic or polycarbonate window mounted in a metal frame matching adjacent door material.
- b. Enclosure types, except NEMA 250 Type 1, to have continuous gasket material around perimeter of window and frame to provide watertight seal.
- c. Window kit to be factory or shop installed before shipment to Project.

8. Bar handle with keyed cylinder lock set.

2.24 RELAYS

A. General-Purpose Relays:

- 1.Manufacturers: Subject to compliance with requirements, provide products by one of the following:
 - a. Allen Bradley; by Rockwell Automation.
 - b. Eaton.
 - c. IDEC Corporation.
 - d. Omron Americas.
 - e. Siemens Industry, Inc., Building Technologies Division.
 - f. Square D; Schneider Electric USA.
- 2.NRTL listed.
- 3.Heavy-duty, electromechanical type; rated for at least 10 A at 250 V ac and 60 Hz.
- 4.SPDT, DPDT, or three-pole double-throw, as required by control application.
- 5.Plug-in-style relay with 8-pin octal or multiblade plug for DPDT relays and 11-pin octal or multiblade plug for three-pole double-throw relays.
- 6.Construct contacts of silver, silver alloy, or gold.
- 7.Enclose relay in a clear transparent polycarbonate dust-tight cover.
- 8.Include LED indication and push-to-test button to test manual operation of relay without power on coil.
- 9.Performance:
 - a. Mechanical Life: At least 10 million cycles.
 - b. Electrical Life: At least 100,000 cycles at rated load.
 - c. Pickup Time: 15 ms or less.
 - d. Dropout Time: 10 ms or less.
 - e. Pull-in Voltage: 85 percent of rated voltage.
 - f. Dropout Voltage: 50 percent of nominal rated voltage.
 - g. Power Consumption: 5 VA or less.
 - h. Ambient Operating Temperatures: Minus 40 to 115 deg F.
10. Equip relays with coil transient suppression to limit transients to non-damaging levels.
11. Plug each relay into industry-standard, 35 mm DIN rail socket. Plug all relays located in control panels into sockets that are mounted on a DIN rail.
12. Include relay socket with screw terminals. Mold into socket the coincident screw terminal numbers.

B. Multifunction Time-Delay Relays:

- 1.Manufacturers: Subject to compliance with requirements, provide products by one of the following:
 - a. Allen Bradley; by Rockwell Automation.
 - b. Eaton.
 - c. IDEC Corporation.
 - d. Omron Americas.
 - e. Siemens Industry, Inc., Building Technologies Division.
 - f. Square D; Schneider Electric USA.

2. NRTL listed.
3. Continuous-duty type, rated for at least 10 A at 240 V ac and 60 Hz.
4. Relay with up to 4 programmable functions to provide on/off delay, interval, and recycle timing functions.
5. Plug-in-style relay with either multi-pin or blade plug.
6. Construct contacts of silver, silver alloy, or gold.
7. Enclose relay in a dust-tight cover.
8. Include knob and dial scale for alternative digital interface for setting delay time.
9. Visual Status Indication: Power "On" and Output "On" status.
10. Performance:
 - a. Mechanical Life: At least 10 million cycles.
 - b. Electrical Life: At least 100,000 cycles at rated load.
 - c. Timing Ranges: Multiple ranges from 0.1 seconds to 100 minutes.
 - d. Repeatability: Within 2 percent.
 - e. Recycle Time: 45 ms.
 - f. Minimum Pulse-Width Control: 50 ms.
 - g. Power Consumption: 5 VA or less.
 - h. Ambient Operating Temperatures: Minus 40 to 115 deg F.
11. Equip relays with transient suppression to limit transients to non-damaging levels.
12. Plug each relay into industry-standard, 35 mm DIN rail socket. Plug all relays located in control panels into sockets that are mounted on a DIN rail.
13. Include relay socket with screw terminals. Mold into socket the coincident screw terminal numbers.

C. Latching Relays:

1. Manufacturers: Subject to compliance with requirements, provide products by one of the following:
 - a. Allen Bradley; by Rockwell Automation.
 - b. Eaton.
 - c. IDEC Corporation.
 - d. Omron Americas.
 - e. Siemens Industry, Inc., Building Technologies Division.
 - f. Square D; Schneider Electric USA.
2. NRTL listed.
3. Continuous-duty type, rated for at least 10 A at 250 V ac and 60 Hz.
4. SPDT, DPDT, or three-pole double-throw, as required by control application.
5. Plug-in-style relay with either multi-pin or blade plug.
6. Construct contacts of silver, silver alloy, or gold.
7. Enclose relay in a clear transparent polycarbonate dust-tight cover.
8. Performance:
 - a. Mechanical Life: At least 10 million cycles.
 - b. Electrical Life: At least 100,000 cycles at rated load.
 - c. Pickup Time: 15 ms or less.
 - d. Dropout Time: 10 ms or less.
 - e. Pull-in Voltage: 85 percent of rated voltage.

- f. Dropout Voltage: 50 percent of nominal rated voltage.
- g. Power Consumption: 2 VA or less.
- h. Ambient Operating Temperatures: Minus 40 to 115 deg F.

- 9. Equip relays with coil transient suppression to limit transients to non-damaging levels.
- 10. Plug each relay into industry-standard, 35 mm DIN rail socket. Plug all relays located in control panels into sockets that are mounted on a DIN rail.
- 11. Relay socket with screw terminals. Mold into socket the coincident screw terminal numbers.

D. Current Sensing Relays:

- 1. Manufacturers: Subject to compliance with requirements, provide products by one of the following:
 - a. Eaton.
 - b. Functional Devices Inc.
 - c. NK Technologies.
 - d. Square D; Schneider Electric USA.
- 2. NRTL listed.
- 3. Monitors ac current.
- 4. Independent adjustable controls for pickup and dropout current.
- 5. Energized when supply voltage is present and current is above pickup setting.
- 6. De-energizes when monitored current is below dropout current.
- 7. Dropout current is adjustable from 50 to 95 percent of pickup current.
- 8. Visual indication of contact status.
- 9. Include current transformer, if required for application.
- 10. House current sensing relay and current transformer if required in its own enclosure. Use NEMA 250, Type 1 or Type 12 enclosure for indoors applications and NEMA 250, Type 4 or Type 4X for outdoor applications.

E. Combination On-Off Status Sensor and On-Off Control Relays:

- 1. Manufacturers: Subject to compliance with requirements, provide products by one of the following:
 - a. Functional Devices Inc.
 - b. Veris Industries.
- 2. Description:
 - a. On-off control and on-off status indication in a single device.
 - b. LED status indication of activated relay and current trigger.
 - c. Closed-Open-Auto override switch located on the load side of relay.
- 3. Performance:
 - a. Ambient Temperature: Minus 30 to 140 deg F.
 - b. Voltage Rating: Single-phase loads rated for 300 V ac. Three-phase loads rated for 600 V ac.

4. Status Indication:

- a. Current Sensor: Integral sensing for single-phase loads up to 20 A and external solid or split sensing ring for three-phase loads up to 150 A.
- b. Current Sensor Range: As required by application.
- c. Current Set Point: Fixed or adjustable, as required by application.
- d. Current Sensor Output:
 - 1) Solid-state, SPDT contact rated for 30 V ac and dc and for 0.4 A.
 - 2) Solid-state, SPDT contact rated for 120 V ac and 1.0 A.
 - 3) Analog, 0 to 5 or 10 V dc.
 - 4) Analog, 4 to 20 mA, loop powered.

5. Relay: SPDT, continuous-duty coil; rated for 10-million mechanical cycles.

6. Enclosure: NEMA 250, Type 12 enclosure for indoor applications; NEMA 250, Type 4X enclosure for outdoor applications.

2.25 ELECTRICAL POWER DEVICES

A. Control Transformers:

1. Sizing Criteria: Size control transformers for total connected load, plus additional 25 percent of connected load for future spare capacity.
2. Transformer Minimum Capacity: 40 VA.
3. Protection: Provide transformers with both primary and secondary fuses. Integral circuit breaker is acceptable in lieu of fuses.
4. Enclosure: House control transformers in NEMA 250 enclosures, type as indicated in "Performance Requirements" Article for application.

B. Power-Line Conditioners:

1. Manufacturers: Subject to compliance with requirements, provide products by one of the following:
 - a. Eaton.
 - b. Emerson Electric Co., Automation Solutions.
 - c. SolaHD; Emerson Electric Co., Automation Solutions.
2. General Power-Line Conditioner Requirements:
 - a. Design to ensure maximum reliability, serviceability, and performance.
 - b. Overall function of power-line conditioner is to receive raw, polluted electrical power and purify it for use by electronic equipment. Power-line conditioner is to provide isolated, regulated, transient, and noise-free sinusoidal power to loads served.
3. Standards: NRTL listed per UL 1012.
4. Performance:
 - a. Single phase, continuous, 100 percent duty rated kVA/kW capacity. Design to supply power for linear or nonlinear, high crest factor, resistive and reactive loads.

- b. Automatically regulate output voltage to within 2 percent or better with input voltage fluctuations of plus 10 to minus 20 percent of nominal when system is loaded 100 percent. Use Variable Range Regulation to obtain improved line voltage regulation when operating under less than full load conditions.
 - 1) At 75 Percent Load: Output voltage automatically regulated to within 3 percent with input voltage fluctuations of plus 10 to minus 35 percent of nominal.
 - 2) At 50 Percent Load: Output voltage automatically regulated to within 3 percent with input voltage fluctuations of plus 10 to minus 40 percent of nominal.
 - 3) At 25 Percent Load: Output voltage automatically regulated to within 3 percent with input voltage fluctuations of plus 10 to minus 45 percent of nominal.
- c. With input voltage distortion of up to 40 percent, limit the output voltage sine wave to maximum harmonic content of 5 percent.
- d. Automatically regulate output voltage to within 2.5 percent when load (resistive) changes from zero to 100 to zero percent.
- e. Output voltage returns to 95 percent of nominal level within two cycles and to 100 percent within three cycles when output is taken from no load to full-resistive load, or vice versa. Recovery from partial resistive load changes is corrected in a shorter period.
- f. K Factor: 30, designed to operate with nonlinear, non-sinusoidal, high crest factor loads without overheating.
- g. Input power factor within 0.95 approaching unity with load power factor as poor as 0.6.
- h. Attenuate load-generated odd current harmonics 23 dB at the input.
- i. Electrically isolate the primary from the secondary. Meet isolation criteria as defined in NFPA 70, Article 250-5D.
- j. Lighting and Surge Protection: Compares to UL 1449 rating of 330 V when subjected to Category B3 (6000 V/3000 A) combination waveform as established by IEEE C62.41.1 and IEEE C62.41.2.
- k. Common-mode noise attenuation of 140 dB.
- l. Transverse-mode noise attenuation of 120 dB.
- m. With loss of input power for up to 16.6 ms, output sine wave remains at usable ac voltage levels.
- n. Reliability of 200,000 hours' MTBF.
- o. At full load, when measured at 1 m distance, audible noise is not to exceed 54 dB.
- p. Approximately 92 percent efficient at full load.

5. Transformer Construction:

- a. Ferroresonant, dry type, convection cooled, 600 V class. Transformer windings of Class H (220 deg C) insulated copper.
- b. Use Class H installation system throughout with operating temperatures not to exceed 150 deg C over a 40 deg C ambient temperature.
- c. Configure transformer primary for multi-input voltage. Include input terminals for source conductors and ground.
- d. Manufacture transformer core using M-6 grade, grain-oriented, stress-relieved transformer steel.

- e. Configure transformer secondary in 240/120 V split with 208 V tap or straight 120 V, depending on power output size.
- f. Electrically isolate the transformer secondary windings from primary windings. Bond neutral conductor to cabinet enclosure and output neutral terminal.
- g. Include interface terminals for output power hot, neutral, and ground conductors.
- h. Label leads, wires, and terminals to correspond with circuit wiring diagram.
- i. Vacuum impregnate transformer with epoxy resin.

6. Cabinet Construction:

- a. Design for panel or floor mounting.
- b. NEMA 250, Type 1 or Type 2 enclosure for indoor applications. NEMA 250, Type 3R for outdoor applications.
- c. Manufacture the cabinet from heavy gauge steel complying with UL 50 or UL 508A.
- d. Include textured baked-on paint finish.

C. DC Power Supplies:

1. Manufacturers: Subject to compliance with requirements, provide products by one of the following:

- a. Acopian Technical Company.
- b. Emerson Electric Co., Automation Solutions.
- c. IDEC Corporation.
- d. Omron Americas.

2. Description: Linear or switched, regulated power supplies with ac input to one or multiple dc output(s).

- a. Include both line and load regulation to ensure stable output.
- b. To protect both power supply and load, include power supply with an automatic current limiting circuit.

3. Features:

- a. Connection: Plug-in style suitable for mating with standard 8-pin octal socket. Include power supply with mating mounting socket.
- b. Housing: Enclose circuitry in a housing.
- c. Local Adjustment: Include screw adjustment on exterior of housing for dc voltage output.
- d. Mounting: DIN rail.
- e. Visual status indicator.

4. Performance:

- a. Input Voltage: Nominally 120 V ac, 60 Hz.
- b. Output Voltage: Nominally 24 V dc with plus or minus 1 V dc adjustment.
- c. Output Current: Minimum 100 mA.
- d. Load Regulation: Within 0.1 percent.
- e. Line Regulation: Within 0.05 percent.
- f. Stability: Within 0.1 percent of rated volts after warmup period.

- g. Ripple: 1 mV rms.

2.26 UNINTERRUPTABLE POWER SUPPLY (UPS) UNITS

- A. Furnish local UPS units, of type indicated, installed with DDC system.

- B. DIN Rail Mounted UPS:

- 1.Manufacturers: Subject to compliance with requirements, provide products by one of the following:

- a. APC by Schneider Electric.
 - b. Emerson Electric Co., Automation Solutions.
 - c. Phoenix Contact.

- 2.Provide continuous, regulated output power without using batteries during brown-out, surge, and spike conditions.

- 3.Performance:

- a. Capacity: Load not to exceed 75 percent of rated capacity.
 - b. Efficiency: Minimum 94 percent.
 - c. Input Voltage: Single phase, 120 V ac, compatible with field power source.
 - d. Load Power Factor Range (Crest Factor): 0.65 to 1.0.
 - e. Output Voltage: 101 to 132 V ac, while input voltage varies between 89 and 152 V ac.
 - f. On Battery Output Voltage: Sine wave.
 - g. Inverter Overload Capacity: Minimum 150 percent for 30 seconds.
 - h. Battery Backup: 10 minutes of operation at full load with battery power.
 - i. Battery Recharge Time: Maximum of six hours to 90 percent capacity after full discharge.
 - j. Transfer Time: 6 ms.
 - k. Surge Voltage Withstand Capacity: IEEE C62.41.1 and IEEE C62.41.2, Categories A and B.

- 4.Automatic bypass operation during fault or overload conditions.

- 5.Integral line-interactive, power condition topology to eliminate all power contaminants.

- 6.Include power switch and visual indication of power, battery, fault, and temperature.

- 7.Include audible alarm of faults with silence feature.

- 8.Include dry contacts (digital output points) for low battery condition and battery-on (primary utility power failure) and connect points to DDC system.

- 9.Batteries: Sealed; maintenance free; replacement without dropping load.

- C. Tower UPS Models through 1000 VA:

- 1.Manufacturers: Subject to compliance with requirements, provide products by one of the following:

- a. APC by Schneider Electric.
 - b. Eaton.
 - c. Toshiba International Corporation.

2. Provide continuous, regulated output power without using batteries during brown-out, surge, and spike conditions.

3. Performance:

- a. Capacity: Load not to exceed 75 percent of rated capacity.
- b. Efficiency: Complying with ENERGY STAR requirements; minimum 91 percent.
- c. Input Voltage: Single phase, 120 V ac, compatible with field power source.
- d. Load Power Factor Range (Crest Factor): 0.65 to 1.0.
- e. Output Voltage: 101 to 132 V ac, while input voltage varies between 89 and 152 V ac.
- f. On Battery Output Voltage: Sine wave.
- g. Inverter Overload Capacity: Minimum 150 percent for 30 seconds.
- h. Battery Backup: 10 minutes of operation at full load with battery power.
- i. Battery Recharge Time: Maximum of four hours to 90 percent capacity after full discharge to cutoff.
- j. Transfer Time: 0 ms.
- k. Surge Voltage Withstand Capacity: IEEE C62.41.1 and IEEE C62.41.2, Categories A and B; 6 kV/200 and 500 A; 100 kHz ring wave.

4. Automatic bypass operation during fault or overload conditions.

5. Integral line-interactive, power condition topology to eliminate all power contaminants.

6. Include power switch and visual indication of power, battery, fault, and temperature.

7. Include audible alarm of faults and front panel silence feature.

8. Receptacles: Minimum four, NEMA WD 1, NEMA WD 6 Configuration 5-15R receptacles.

9. Remote Alarms: Include dry contacts (digital output points) or serial communication interface for low battery condition and battery-on (primary utility power failure) and connect points to DDC system.

10. Batteries: Sealed type; maintenance free. Battery replacement is to be front accessible by user without dropping load.

11. Install tower models in enclosures rated for location.

D. UPS Models through 3000 VA: Tower and Rack.

1. Manufacturers: Subject to compliance with requirements, provide products by the following:

- a. APC by Schneider Electric.
- b. Eaton.
- c. Toshiba International Corporation.

2. NRTL Listing: UL 1778.

3. Provide continuous, regulated output power without using batteries during brown-out, surge, and spike conditions.

4. Performance:

- a. Capacity: Load not to exceed 75 percent of UPS rated capacity.
- b. Efficiency: Complying with ENERGY STAR requirements; minimum 91 percent.
- c. Input Voltage: Single phase, 120 V ac, plus 20 to minus 30 percent.
- d. Power Factor: Minimum 0.95 at full load.
- e. Output Voltage: Single phase, 120 V ac, within 2 percent.
- f. Inverter overload capacity to be minimum 150 percent for 30 seconds.
- g. Battery Backup: 10 minutes of operation at full load with battery power.

- h. Battery Recharge Time: Maximum of 6 hours to 90 percent capacity.
- i. Transfer Time: 0 ms.

- 5. LCD display with operator interface.
- 6. Receptacles: Minimum 6, NEMA WD 1, NEMA WD 6 Configuration 5-15R or 5-20R receptacles.
- 7. Automatic bypass operation during fault or overload conditions.
- 8. Remote Alarms: Include dry contacts (digital output points) or serial communication interface for low battery condition and battery-on (primary utility power failure) and connect points to DDC system.
- 9. Batteries: Sealed; maintenance free.
- 10. Enclosures: Install tower models in enclosures rated for location. Install rack models installed on matching racks, as applicable to particular installation location and space availability/configuration.

2.27 CONTROL WIRE AND CABLE

A. Wire: Single conductor control wiring above 24 V.

- 1. Wire Size: Minimum 16 AWG.
- 2. Conductors: 7/24 soft annealed copper strand with 2- to 2.5-inch lay.
- 3. Conductor Insulation: 600 V, Type THWN or Type THHN, and 90 deg C in accordance with UL 83.
- 4. Conductor Insulation Colors: Black (hot), white (neutral), and green (ground).
- 5. Furnish on spools.

B. Single, Twisted-Shielded, Instrumentation Cable above 24 V:

- 1. Wire Size: Minimum 20 AWG.
- 2. Conductors: Twisted, 7/24 soft annealed copper strand with a 2- to 2.5-inch lay.
- 3. Conductor Insulation: Type THHN/THWN or Type TFN rating.
- 4. Conductor Insulation Colors:
 - a. Twisted Pair: Black and white.
 - b. Twisted Triad: Black, red, and white.
- 5. Shielding: 100 percent type, 0.35/0.5-mil aluminum/Mylar tape, helically applied with 25 percent overlap, and aluminum side in with tinned copper drain wire.
- 6. Outer Jacket Insulation: 600 V, 90 deg C rating, and Type TC cable.
- 7. Furnish on spools.

C. Single, Twisted-Shielded, Instrumentation Cable 24 V and Less:

- 1. Wire Size: Minimum 20 AWG.
- 2. Conductors: Twisted, 7/24 soft annealed copper stranding with a 2- to 2.5-inch lay.
- 3. Conductor Insulation: Nominal 15-mil thickness, constructed from flame-retardant PVC.
- 4. Conductor Insulation Colors:
 - a. Twisted Pair: Black and white.
 - b. Twisted Triad: Black, red, and white.

5. Shielding: 100 percent type, 1.35-mil aluminum/polymer tape, helically applied with 25 percent overlap, and aluminum side in with tinned copper drain wire.
6. Outer Jacket Insulation: 300 V, 105 deg C rating, and Type PLTC cable.
7. Furnish on spools.

D. LAN and Communication Cable: Comply with DDC system manufacturer requirements for network being installed.

1. Comply with following requirements for balanced twisted pair cable described in Section 260523 "Control-Voltage Electrical Power Cables."

2.

- a. Plenum rated.
- b. Unique color that is different from other cables used on Project.

2.28 RACEWAYS

- A. Comply with requirements in Section 260533.13 "Conduits for Electrical Systems" and Section 260533.16 "Boxes and Covers for Electrical Systems" for electrical power raceways and boxes.
- B. Comply with requirements in Section 270528 "Pathways for Communications Systems" for raceways for balanced twisted pair cables and optical fiber cables.

2.29 OPTICAL FIBER CABLE AND CONNECTORS

- A. Comply with requirements in Section 271323 "Communications Optical Fiber Backbone Cabling" for optical fiber backbone cabling and connectors.
- B. Comply with requirements in Section 271523 "Communications Optical Fiber Horizontal Cabling" for optical fiber horizontal cabling and connectors.

2.30 ACCESSORIES

A. Control Damper Blade Limit Switches:

1. Application: Sense positive open and/or closed position of damper blades.
2. NEMA 250, Type 13, oiltight construction. Install in instrument enclosure where required for additional environmental protection.
3. Arrange for mounting application, and to prevent "over-center" operation.

4. Industrial Grade:

- a. Manufacturers: Subject to compliance with requirements, provide products by the following:
 - 1) ControlAir, Inc.
 - 2) Fischer; Emerson Electric Co., Automation Solutions.

3) Marsh Bellofram.

b. Description: Transducer converting an electronic current (I) or voltage (E) AO signal.

c. Features:

- 1) Adjustments: Separate zero and span calibration adjustments.
- 2) Conduit Connections: Nominal 1/2 inch.
- 3) Enclosure: NEMA 250, Type 4X.
- 4) Pressure Gauge: Integral output pressure gauge.

d. Performance:

- 1) Accuracy: Within 0.5 percent of output span.
- 2) Hysteresis: Within 0.5 percent of output span.
- 3) Linearity: Within 0.5 percent of output span.
- 4) Repeatability: Within 0.5 percent of output span.
- 5) Output Capacity: Not less than 5 scfm at 15 psig.
- 6) Air Consumption: Maximum of 5 scfh at 15 psig.
- 7) Ambient Temperature: Suitable for operation in ambient temperature range of minus 20 to 150 deg F.
- 8) Pressure: Up to 50 psig without damage.
- 9) Vibration: Construct entire assembly so shock and vibration will not harm transducer or affect accuracy.

e. Applications:

- 1) All applications, except for terminal units and other applications with commercial-grade transducers.

B. E/P Switch:

- 1.Body: Cast aluminum or brass; three pipe body (common, normally open, and normally closed).
- 2.Internal Components: Brass, copper, steel, or stainless steel.
- 3.Connections: Barb, or threaded for mating to compression fittings.
- 4.Rating: 30 psig when installed in systems below 25 psig; 150 psig when installed in systems above 25 psig.
- 5.Features: Include coil transient suppression.

C. Instrument Enclosures:

- 1.Manufacturers: Subject to compliance with requirements, provide products by one of the following:
 - a. Hammond Mfg. Co. Inc.
 - b. Hoffman; brand of nVent Electrical plc.
 - c. Saginaw Control and Engineering.
- 2.Application: Include instrument enclosure for secondary protection to comply with requirements indicated in "Performance Requirements" Article.
- 3.Certification: NRTL listed and labeled to UL 50 or UL 508A as applicable.

4. Subpanel:

- a. Size enclosure with least 25 percent spare area on subpanel.
- b. Mount instrument(s) within enclosure on internal subpanel(s).

5. Identification: Include on face of enclosure an engraved, laminated phenolic nameplate for each instrument installed within enclosure.

6. Raceways: For enclosures housing multiple instruments, route tubing, cable, and wiring within enclosure in a raceway having continuous removable cover.

7. Access: Provide enclosures larger than 12 inches with hinged full-size face cover.

8. Security: Equip enclosures with lock and common key.

2.31 IDENTIFICATION

A. Instrument Air Pipe and Tubing:

1. Engraved tag bearing the following information:

- a. Service (Example): "Instrument Air."
- b. Pressure Range (Example): 0 to 30 psig.

2. Letter size minimum of 0.25 inch high.

3. Engraved phenolic consisting of three layers of rigid laminate. Top and bottom layers color-coded blue with contrasting white center exposed by engraving through outer layer.

4. Include tag with brass grommet, chain, and S-hook.

B. Control Equipment, Instruments, and Control Devices:

1. Self-adhesive label bearing unique identification.

- a. Include instruments with unique identification identified by equipment being controlled or monitored, followed by point identification.

2. Letter size as follows:

- a. Servers: Minimum of 0.5 inch high.
- b. DDC Controllers: Minimum of 0.5 inch high.
- c. Gateways: Minimum of 0.5 inch high.
- d. Repeaters: Minimum of 0.5 inch high.
- e. Enclosures: Minimum of 0.5 inch high.
- f. Electrical Power Devices: Minimum of 0.25 inch high.
- g. UPS units: Minimum of 0.5 inch high.
- h. Accessories: Minimum of 0.25 inch high.
- i. Instruments: Minimum of 0.25 inch high.
- j. Control Damper and Valve Actuators: Minimum of 0.25 inch high.

3. Engraved phenolic consisting of three layers of rigid laminate. Top and bottom layers color-coded black with contrasting white center exposed by engraving through outer layer.

4. Fastened with drive pins.

5. Instruments, control devices, and actuators with Project-specific identification tags having unique identification numbers following requirements indicated and provided by original manufacturer do not require additional identification.

C. Valve Tags:

1. Brass tags and brass chains attached to valve.
2. Tag Size: Minimum 1.5 inches in diameter.
3. Include tag with unique valve identification indicating control influence such as flow, level, pressure, or temperature; followed by location of valve, and followed by three-digit sequential number. For example: TV-1.001.
4. Valves with Project-specific identification tags having unique identification numbers following requirements indicated and provided by original manufacturer do not require an additional tag.

D. Raceway and Boxes:

1. Comply with requirements for identification specified in Section 260553 "Identification for Electrical Systems."
2. Paint cover plates on junction boxes and conduit same color as tape banding for conduits. After painting, label cover plate "HVAC Controls" using engraved phenolic tag.

E. Equipment Warning Labels:

1. Self-adhesive label with pressure-sensitive adhesive back and peel-off protective jacket.
2. Lettering size at least 14-point type with white lettering on red background.
3. Warning label to read "CAUTION-Equipment operated under remote automatic control and may start or stop at any time without warning. Switch electric power disconnecting means to OFF position before servicing."
4. Lettering to be enclosed in a white line border. Edge of label is to extend at least 0.25 inch beyond white border.

2.32 SOURCE QUALITY CONTROL

- A. Testing Agency: Engage a qualified testing agency to evaluate the following in accordance with industry standards for each product, and to verify DDC system reliability specified in performance requirements:
1. DDC controllers.
 2. Gateways.
 3. Routers.
- B. Product(s) and material(s) will be considered defective if it does not pass tests and inspections.
- C. Prepare test and inspection reports.

PART 3 - EXECUTION

3.1 EXAMINATION

- A. Examine substrates and conditions for compliance with requirements for installation tolerances and other conditions affecting performance of the Work.
 - 1. Verify compatibility with and suitability of substrates.
- B. Examine roughing-in for instruments installed in piping to verify actual locations of connections before installation.
- C. Examine roughing-in for instruments installed in duct systems to verify actual locations of connections before installation.
- D. Examine walls, floors, roofs, and ceilings for suitable conditions where product will be installed.
- E. Prepare written report, endorsed by Installer, listing conditions detrimental to performance of the Work.
- F. Proceed with installation only after unsatisfactory conditions have been corrected.

3.2 DDC SYSTEM INTERFACE WITH OTHER SYSTEMS AND EQUIPMENT

- A. Communication Interface to Equipment with Integral Controls:
 - 1. DDC system has communication interface with equipment having integral controls and having communication interface for remote monitoring or control.
 - 2. Equipment to Be Connected:
 - a. Domestic water heaters specified in Section 223300 "Electric, Domestic-Water Heaters".
 - b. Air-terminal units specified in Section 233600 "Air Terminal Units."
 - c. Roof-top units specified in Section 237416.11 "Packaged, Small-Capacity, Rooftop Air-Conditioning Units."
 - d. Switchboards specified in Section 262300 "Low-Voltage Switchgear."
 - e. Motor-control centers specified in Section 262419 "Motor-Control Centers."
 - f. Variable-frequency controllers specified in Section 262923 "Variable-Frequency Motor Controllers."
 - g. Diesel emergency engine generators specified in Section 263213.13 "Diesel-Engine-Driven Generator Sets."
 - h. Bi-fuel emergency engine generators specified in Section 263213.19 "Bi-Fuel-Engine-Driven Generator Sets."
 - i. UPS specified in Section 263353 "Static Uninterruptible Power Supply."
- B. Communication Interface to Other Building Systems:
 - 1. DDC system communicates with systems having communication interface.
 - 2. Systems to Be Connected:

- a. Power monitoring specified in Section 260913 "Electrical Power Monitoring."
- b. Lighting controls specified in Section 260936 "Modular Dimming Controls."
- c. Lighting controls specified in Section 260943.16 "Addressable Luminaire Lighting Controls."
- d. Lighting controls specified in Section 260943.23 "Relay-Based Lighting Controls."
- e. Fire-alarm system specified in Section 284621.11 "Addressable Fire-Alarm Systems."

3.3 PREINSTALLATION INTEGRATION TESTING

- A. Perform the following pretesting of other systems and equipment integration with DDC system before field installation:
 1. Test all communications in a controlled environment to ensure connectivity.
 2. Load software and demonstrate functional compliance with each control sequence of operation indicated.
 3. Using simulation, demonstrate compliance with sequences of operation and other requirements indicated including, but not limited to, the following:
 - a. HVAC equipment controlled through DDC system, such as air-handling units.
 - b. Equipment faults and system recovery with fault annunciation.
 - c. Analog and Boolean value alarming and annunciation.
 4. Develop a method for testing interfaces before deployment.
 5. Submit documentation supporting compliance upon request.

3.4 DDC SYSTEM INTERFACE WITH EXISTING SYSTEMS

- A. Integration with Existing Enterprise System:
 1. Interface DDC system with an existing enterprise system to adhere to Owner standards already in-place and to achieve integration.
 2. Owner's control system integrator to provide the following services:
 - a. Enterprise system expansion and development of graphics, logs, reports, trends, and other operational capabilities of enterprise system for I/O being added to DDC control system for use by enterprise system operators.
 - b. Limited assistance during commissioning to extent of DDC system integration with existing enterprise system.
 - c. Prepare on-site demonstration mockup of integration of DDC system to be installed with existing system before installing DDC system.
 3. Engage Owner's control system integrator to provide the following services:
 - a. Enterprise system expansion and development of graphics, logs, reports, trends, and other operational capabilities of enterprise system for I/O being added to DDC control system for use by enterprise system operators.

- b. Limited assistance during commissioning to extent of DDC system integration with existing enterprise system.
 - c. Prepare on-site demonstration mockup of integration of DDC system to be installed with existing system before installing DDC system.
4. Attend meetings with control system integrator to integrate DDC system.

3.5 CONTROL DEVICES FOR INSTALLATION BY INSTALLERS

- A. Deliver selected control devices, specified in indicated HVAC instrumentation and control device Sections, to identified equipment and systems manufacturers for factory installation and to identified installers for field installation.
- B. Deliver the following to duct fabricator and Installer for installation in ductwork. Include installation instructions to Installer and supervise installation for compliance with requirements.
 - 1. Control dampers, which are specified in Section 230923.12 "Control Dampers."
 - 2. Airflow sensors and switches, which are specified in Section 230923.14 "Flow Instruments."
 - 3. Pressure sensors, which are specified in Section 230923.23 "Pressure Instruments."

3.6 CONTROL DEVICES FOR EQUIPMENT MANUFACTURER FACTORY INSTALLATION

- A. Deliver the following to air-handling unit manufacturer for factory installation. Include installation instructions to air-handling unit manufacturer and supervise installation for compliance with requirements.
 - 1. Programmable application controller.
 - 2. Unit-mounted DDC control dampers and actuators, which are specified in Section 230923.12 "Control Dampers."
 - 3. Unit-mounted airflow sensors, switches, and transmitters, which are specified in Section 230923.14 "Flow Instruments."
 - 4. Unit-mounted leak-detection switches, which are specified in Section 230923.18 "Leak Detection Instruments."
 - 5. Unit-mounted pressure sensors, switches, and transmitters, which are specified in Section 230923.23 "Pressure Instruments."
 - 6. Unit-mounted speed sensors, switches, and transmitters, which are specified in Section 230923.24 "Speed Instruments."
 - 7. Unit-mounted temperature sensors, switches, and transmitters. Air-temperature sensors, switches, and transmitters are specified in Section 230923.27 "Temperature Instruments."
 - 8. Relays.
- B. Deliver the following to terminal unit manufacturer for factory installation. Include installation instructions to terminal unit manufacturer.
 - 1. Programmable application controller.
 - 2. Electric damper actuator. Damper actuators are specified in Section 230923.12 "Control Dampers."

3. Unit-mounted flow and pressure sensors, transmitters, and transducers. Flow sensors, transmitters, and transducers are specified in Section 230923.14 "Flow Instruments." Pressure sensors, switches, and transmitters are specified in Section 230923.23 "Pressure Instruments."
 4. Unit-mounted temperature sensors. Air-temperature sensors, switches, and transmitters are specified in Section 230923.27 "Temperature Instruments."
 5. Relays.
- C. Deliver the following to fan-coil unit manufacturer for factory installation. Include installation instructions to fan-coil unit manufacturer.
1. Programmable application controller.
 2. Unit-mounted temperature sensors. Air-temperature sensors, switches, and transmitters are specified in Section 230923.27 "Temperature Instruments."
 3. Flow and pressure switches. Air and liquid flow sensors, transmitters, and transducers are specified in Section 230923.14 "Flow Instruments." Pressure sensors, switches, and transmitters are specified in Section 230923.23 "Pressure Instruments."
 4. Relays.

3.7 GENERAL INSTALLATION REQUIREMENTS

- A. Install products to satisfy more stringent of all requirements indicated.
- B. Install products level, plumb, parallel, and perpendicular with building construction.
- C. Support products, tubing, piping wiring, and raceways. Brace products to prevent lateral movement and sway or a break in attachment.
- D. If codes and referenced standards are more stringent than requirements indicated, comply with requirements in codes and referenced standards.
- E. Fabricate openings and install sleeves in ceilings, floors, roof, and walls required by installation of products. Before proceeding with drilling, punching, and cutting, check for concealed work to avoid damage. Patch, flash, grout, seal, and refinish openings to match adjacent condition.
- F. Firestop Penetrations Made in Fire-Rated Assemblies: Comply with requirements in Section 078413 "Penetration Firestopping."
- G. Seal penetrations made in acoustically rated assemblies. Comply with requirements in Section 079200 "Joint Sealants."
- H. Welding Requirements:
 1. Restrict welding and burning to supports and bracing.
 2. No equipment is cut or welded without approval. Welding or cutting will not be approved if there is risk of damage to adjacent Work.
 3. Welding, where approved, is to be by inert-gas electric arc process and is to be performed by qualified welders in accordance with applicable welding codes.
 4. If requested on-site, show satisfactory evidence of welder certificates indicating ability to perform welding work intended.

I. Fastening Hardware:

1. Wrenches, pliers, and other tools that damage surfaces of rods, nuts, and other parts are prohibited for work of assembling and tightening fasteners.
2. Tighten bolts and nuts firmly and uniformly. Do not overstress threads by excessive force or by oversized wrenches.
3. Lubricate threads of bolts, nuts, and screws with graphite and oil before assembly.

- J. If product locations are not indicated, install products in locations that are accessible and that will permit service and maintenance from floor, equipment platforms, or catwalks without removal of permanently installed furniture and equipment.

3.8 INSTALLATION OF SERVERS

- A. Install server(s) at location(s) indicated on Drawings.
- B. Install number of servers required to suit requirements indicated. Review Project requirements and indicate layout of proposed server location in Shop Drawings.
- C. Install software indicated on server(s) and verify that software functions properly.
- D. Develop Project-specific graphics, trends, reports, logs, and historical database.
- E. Power servers through dedicated UPS unit. Locate UPS adjacent to server. Install rack-mounted UPS units for powering rack-mounted servers and tower UPS units for tower servers.

3.9 INSTALLATION OF PRINTERS

- A. Install Owner-furnished printers at location(s) indicated on Drawings.

3.10 INSTALLATION OF GATEWAYS

- A. Install gateways if required for DDC system communication interface requirements indicated.
 1. Install gateway(s) required to suit indicated requirements.
- B. Test gateways to verify that communication interface functions properly.

3.11 INSTALLATION OF ROUTERS

- A. Install routers if required for DDC system communication interface requirements indicated.
 1. Install router(s) required to suit indicated requirements.
- B. Test routers to verify that communication interface functions properly.

3.12 INSTALLATION OF CONTROLLERS

- A. Install controllers in enclosures to comply with indicated requirements.
- B. Connect controllers to field power supply and to UPS units where indicated.
- C. Install controllers with latest version of applicable software and configure to execute requirements indicated.
- D. Test and adjust controllers to verify operation of connected I/O to achieve performance indicated requirements while executing sequences of operation.
- E. Installation of Network Controllers:
 - 1. DDC system provider and DDC system manufacturer to determine quantity and location of network controllers to satisfy requirements indicated. Provide minimum quantity indicated.
 - 2. Install controllers in a protected location that is easily accessible by operators.
 - 3. Locate top of controller within 72 inches of finished floor.
- F. Installation of Programmable Application Controllers:
 - 1. DDC system provider and DDC system manufacturer to determine quantity and location of programmable application controllers to satisfy requirements indicated. Provide minimum quantity indicated.
 - 2. Install controllers in a protected location that is easily accessible by operators.
 - 3. Locate top of controller within 72 inches of finished floor, except where dedicated controllers are installed at terminal units.
- G. Application-Specific Controllers:
 - 1. DDC system provider and DDC system manufacturer to determine quantity and location of application-specific controllers to satisfy requirements indicated. Provide minimum quantity indicated.
 - 2. For controllers not mounted directly on equipment being controlled, install controllers in a protected location that is easily accessible by operators.

3.13 INSTALLATION OF ENCLOSURES

- A. Install the following items in enclosures, to comply with indicated requirements:
 - 1. Gateways.
 - 2. Routers.
 - 3. Controllers.
 - 4. Electrical power devices.
 - 5. UPS units.
 - 6. Relays.
 - 7. Accessories.
 - 8. Instruments.
 - 9. Actuators.

- B. Attach wall-mounted enclosures to wall using the following types of steel struts:
 - 1. For NEMA 250, Type 1 Enclosures: Use painted steel strut and hardware.
 - 2. For NEMA 250, Type 4 Enclosures and Enclosures Located Outdoors: Use stainless steel strut and hardware.
 - 3. Install plastic caps on exposed cut edges of strut.
- C. Align top or bottom of adjacent enclosures of like size.
- D. Install floor-mounted enclosures located in mechanical equipment rooms on concrete housekeeping pads. Attach enclosure legs using galvanized-steel or stainless steel anchors.
- E. Install continuous and fully accessible wireways to connect conduit, wire, and cable to multiple adjacent enclosures. Wireways used for application are to have protection equal to NEMA 250 rating of connected enclosures.

3.14 ELECTRIC POWER CONNECTIONS

- A. Connect electrical power to DDC system products requiring electrical power connections.
- B. Design of electrical power to products not indicated with electric power is delegated to DDC system provider and installing trade to provide a fully functioning DDC system. Work is to comply with NFPA 70 and other requirements indicated.
- C. Comply with requirements in Section 262816 "Enclosed Switches and Circuit Breakers" for electrical power circuit breakers.
- D. Comply with requirements in Section 260519 "Low-Voltage Electrical Power Conductors and Cables" for electrical power conductors and cables.
- E. Comply with requirements in Section 260533.13 "Conduits for Electrical Systems," Section 260533.16 "Boxes and Covers for Electrical Systems," and Section 260533.23 "Surface Raceways for Electrical Systems" for electrical power raceways and boxes.

3.15 INSTALLATION OF IDENTIFICATION

- A. Identify system components, wiring, cabling, and terminals. Comply with requirements in Section 260553 "Identification for Electrical Systems" for identification products and installation.
- B. Install self-adhesive labels with unique identification on face for each of the following:
 - 1. Server.
 - 2. Gateway.
 - 3. Router.
 - 4. Protocol analyzer.
 - 5. DDC controller.
 - 6. Enclosure.
 - 7. Electrical power device.
 - 8. UPS unit.

9. Accessory.

- C. Install unique instrument identification for each instrument connected to DDC controller.
- D. Install unique identification for each control damper actuator connected to DDC controller.
- E. Where product is installed above accessible tile ceiling, also install matching identification on face of ceiling grid located directly below.
- F. Where product is installed above an inaccessible ceiling, also install identification on face of access door directly below.
- G. Warning Labels and Signs:
 - 1. Permanently attach to equipment that can be automatically started by DDC control system.
 - 2. Locate where highly visible near power service entry points.

3.16 INSTALLATION OF NETWORKS

- A. Install optical fiber cable when connecting between the following network devices and when located in different buildings on campus:
 - 1. Operator workstations.
 - 2. Operator workstations and network controllers.
 - 3. Network controllers.
- B. Install balanced twisted pair or optical fiber cable when connecting between the following network devices:
 - 1. Operator workstations.
 - 2. Operator workstations and network controllers.
 - 3. Network controllers.
- C. Install balanced twisted pair or copper cable (as required by equipment) when connecting between the following:
 - 1. Gateways.
 - 2. Gateways and network controllers or programmable application controllers.
 - 3. Routers.
 - 4. Routers and network controllers or programmable application controllers.
 - 5. Network controllers and programmable application controllers.
 - 6. Programmable application controllers.
 - 7. Programmable application controllers and application-specific controllers.
 - 8. Application-specific controllers.
- D. Install cable in continuous raceway.
 - 1. Where indicated on Drawings, cable trays may be used for copper cable in lieu of conduit.

3.17 NETWORK NAMING AND NUMBERING

A. Coordinate with Owner and provide unique naming and addressing for networks and devices.

B. ASHRAE 135 Networks:

1. MAC Address:

- a. Assign and document a MAC address unique to its network for every network device.
- b. Ethernet Networks: Document MAC address assigned at its creation.
- c. MS/TP Networks: Assign from 00 to 64.

2. Network Numbering:

- a. Assign unique numbers to each new network.
- b. Provide ability for changing network number through device switches or operator interface.
- c. DDC system, with all possible connected LANs, can contain up to 65,534 unique networks.

3. Device Object Identifier Property Number:

- a. Assign unique device object identifier property numbers or device instances for each device network.
- b. Provide for future modification of device instance number by device switches or operator interface.
- c. LAN is to support up to 4,194,302 unique devices.

4. Device Object Name Property Text:

- a. Device object name property field to support 32 minimum printable characters.
- b. Assign unique device "Object Name" property names with plain-English descriptive names for each device.
 - 1) Example 1: Device object name for device controlling heating water boiler plant at Building 1000 would be "Heating Water System Bldg. 1000."
 - 2) Example 2: Device object name for VAV terminal unit controller could be "VAV Unit 102."

5. Object Name Property Text for Other Than Device Objects:

- a. Object name property field is to support 32 minimum printable characters.
- b. Assign object name properties with plain-English names descriptive of application.
 - 1) Example 1: "Zone 1 Temperature."
 - 2) Example 2 "Fan Start and Stop."

6. Object Identifier Property Number for Other Than Device Objects:

- a. Assign object identifier property numbers according to Drawings or tables indicated.

- b. If not indicated, object identifier property numbers may be assigned at Installer's discretion but must be approved by Owner in advance, be documented, and be unique for like object types within device.

3.18 INSTALLATION OF CONTROL WIRE, CABLE, AND RACEWAY

A. Comply with NECA 1.

B. Wire and Cable Installation:

1. Comply with installation requirements in Section 260523 "Control-Voltage Electrical Power Cables."
2. Comply with installation requirements in Section 271313 "Communications Copper Backbone Cabling."
3. Comply with installation requirements in Section 271513 "Communications Copper Horizontal Cabling."
4. Install cables with protective sheathing that is waterproof and capable of withstanding continuous temperatures of 90 deg C with no measurable effect on physical and electrical properties of cable.
 - a. Provide shielding to prevent interference and distortion from adjacent cables and equipment.
5. Terminate wiring in a junction box.
 - a. Clamp cable over jacket in a junction box.
 - b. Individual conductors in the stripped section of cable is to be slack between the clamping point and terminal block.
6. Terminate field wiring and cable not directly connected to instruments and control devices having integral wiring terminals using terminal blocks.
7. Install signal transmission components in accordance with IEEE C2, REA Form 511a, NFPA 70, and as indicated.
8. Use shielded cable to transmitters.
9. Use shielded cable to temperature sensors.
10. Perform continuity and meager testing on wire and cable after installation.

C. Conduit Installation:

1. Comply with Section 260533.13 "Conduits for Electrical Systems," Section 260533.16 "Boxes and Covers for Electrical Systems," and Section 260533.23 "Surface Raceways for Electrical Systems" for control-voltage conductors.
2. Comply with Section 270528 "Pathways for Communications Systems" for balanced twisted pair cabling and optical fiber installation.

3.19 INSTALLATION OF OPTICAL FIBER CABLE SYSTEMS

- A. Comply with installation requirements in Section 271323 "Communications Optical Fiber Backbone Cabling."

- B. Comply with installation requirements in Section 271523 "Communications Optical Fiber Horizontal Cabling."

3.20 FIELD QUALITY CONTROL

- A. Testing Agency: Engage a qualified testing agency to perform tests and inspections.
- B. Manufacturer's Field Service: Engage a factory-authorized service representative to test and inspect components, assemblies, and installations, including connections.
- C. Tests and Inspections: Perform the following tests and inspections with the assistance of a factory-authorized service representative:
 - 1. Perform each visual and mechanical inspection and electrical test stated in NETA ATS. Certify compliance with test parameters.
 - 2. Test and adjust controls and safeties. Replace damaged and malfunctioning controls and equipment.
- D. Optical Fiber Cable Testing:
 - 1. Perform preinstallation, in-progress, and final tests, supplemented by additional tests, as necessary.
 - 2. Preinstallation Cable Verification: Verify integrity and serviceability for new cable lengths before installation. This assurance may be provided by using vendor verification documents, testing, or other methods. At a minimum, furnish evidence of verification for cable attenuation and bandwidth parameters.
 - 3. In-Progress Testing: Perform standard tests for correct pair identification and termination during installation to ensure proper installation and cable placement. Perform tests in addition to those specified if there is any reason to question condition of material furnished and installed. Testing accomplished is to be documented by agency conducting tests. Submit test results for Project record.
 - 4. Final Testing: Perform final test of installed system to demonstrate acceptability as installed. Perform testing according to test plan supplied by DDC system manufacturer. Correct defective Work or material and retest. At a minimum, final testing for cable system, including spare cable, to verify compliance of attenuation, length, and bandwidth parameters with performance indicated.
 - 5. Test Equipment: Use optical fiber time-domain reflectometer for testing of length and optical connectivity.
 - 6. Test Results: Record test results and submit copy of test results for Project record.

3.21 DDC SYSTEM I/O CHECKOUT PROCEDURES

- A. Check installed products before continuity tests, leak tests, and calibration.
- B. Check instruments for proper location and accessibility.
- C. Check instruments for proper installation on direction of flow, elevation, orientation, insertion depth, or other applicable considerations that will impact performance.

- D. Check instrument tubing for proper isolation, fittings, slope, dirt legs, drains, material, and support.
- E. Control Damper Checkout:
 - 1. Verify that control dampers are installed correctly for flow direction.
 - 2. Verify that proper blade alignment, either parallel or opposed, has been provided.
 - 3. Verify that damper frame attachment is properly secured and sealed.
 - 4. Verify that damper actuator and linkage attachment are secure.
 - 5. Verify that actuator wiring is complete, enclosed, and connected to correct power source.
 - 6. Verify that damper blade travel is unobstructed.
- F. Instrument Checkout:
 - 1. Verify that instrument is correctly installed for location, orientation, direction, and operating clearances.
 - 2. Verify that attachment is properly secured and sealed.
 - 3. Verify that conduit connections are properly secured and sealed.
 - 4. Verify that wiring is properly labeled with unique identification, correct type, and size and is securely attached to proper terminals.
 - 5. Inspect instrument tag against approved submittal.
 - 6. For instruments with tubing connections, verify that tubing attachment is secure and isolation valves have been provided.
 - 7. For flow instruments, verify that recommended upstream and downstream distances have been maintained.
 - 8. For temperature instruments, verify the following:
 - a. Sensing element type and proper material.
 - b. Length and insertion.

3.22 DDC SYSTEM I/O ADJUSTMENT, CALIBRATION, AND TESTING

- A. Calibrate each instrument installed that is not factory calibrated and provided with calibration documentation.
- B. Provide written description of proposed field procedures and equipment for calibrating each type of instrument. Submit procedures before calibration and adjustment.
- C. For each analog instrument, make three-point test of calibration for both linearity and accuracy.
- D. Equipment and procedures used for calibration to comply with instrument manufacturer's written instructions.
- E. Provide diagnostic and test equipment for calibration and adjustment.
 - 1. Use field testing and diagnostic instruments and equipment with an accuracy at least twice the instrument accuracy of instrument to be calibrated. For example, test and calibrate an installed instrument with accuracy of 1 percent using field testing and diagnostic instrument with accuracy of 0.5 percent or better.

- F. Calibrate each instrument in accordance with instruction manual supplied by instrument manufacturer.
- G. If after calibration the indicated performance cannot be achieved, replace out-of-tolerance instruments.
- H. Comply with field testing requirements and procedures indicated by ASHRAE's Guideline 11, "Field Testing of HVAC Controls Components," in the absence of specific requirements, and to supplement requirements indicated.
- I. Analog Signals:
 - 1. Check analog voltage signals using a precision voltage meter at zero, 50, and 100 percent.
 - 2. Check analog current signals using a precision current meter at zero, 50, and 100 percent.
 - 3. Check resistance signals for temperature sensors at zero, 50, and 100 percent of operating span using a precision-resistant source.
- J. Digital Signals:
 - 1. Check digital signals using a jumper wire.
 - 2. Check digital signals using an ohmmeter to test for contact making or breaking.
- K. Control Dampers:
 - 1. Stroke and adjust control dampers following manufacturer's recommended procedure, from 100 percent open to 100 percent closed and back to 100 percent open.
 - 2. Check and document open and close cycle times for applications with cycle time less than 30 seconds.
 - 3. For control dampers equipped with positive position indication, check feedback signal at multiple positions to confirm proper position indication.
- L. Meters: Check meters at zero, 50, and 100 percent of Project design values.
- M. Sensors: Check sensors at zero, 50, and 100 percent of Project design values.
- N. Switches: Calibrate switches to make or break contact at set points indicated.
- O. Transmitters:
 - 1. Check and calibrate transmitters at zero, 50, and 100 percent of Project design values.
 - 2. Calibrate resistance temperature transmitters at zero, 50, and 100 percent of span using a precision-resistant source.

3.23 DDC SYSTEM CONTROLLER CHECKOUT

- A. Verify power supply.
 - 1. Verify voltage, phase, and hertz.
 - 2. Verify that protection from power surges is installed and functioning.
 - 3. Verify that ground fault protection is installed.

- 4.If applicable, verify if connected to UPS unit.
- 5.If applicable, verify if connected to backup power source.
- 6.If applicable, verify that power conditioning units are installed.

- B. Verify that wire and cabling are properly secured to terminals and labeled with unique identification.
- C. Verify that spare I/O capacity is provided.

3.24 DDC CONTROLLER I/O CONTROL LOOP TESTS

A. Testing:

- 1.Test every I/O point connected to DDC controller to verify that safety and operating control set points are as indicated and as required to operate controlled system safely and at optimum performance.
- 2.Test every I/O point throughout its full operating range.
- 3.Test every control loop to verify that operation is stable and accurate.
- 4.Adjust control loop proportional, integral, and derivative settings to achieve optimum performance while complying with performance requirements indicated. Document testing of each control loop's precision and stability via trend logs.
- 5.Test and adjust every control loop for proper operation according to sequence of operation.
- 6.Test software and hardware interlocks for proper operation. Correct deficiencies.
- 7.Operate each analog point at the following:
 - a. Upper quarter of range.
 - b. Lower quarter of range.
 - c. At midpoint of range.
- 8.Exercise each binary point.
- 9.For every I/O point in DDC system, read and record each value at operator workstation, at DDC controller, and at field instrument simultaneously. Value displayed at operator workstation, at DDC controller, and at field instrument must match.
10. Prepare and submit report documenting results for each I/O point in DDC system and include in each I/O point a description of corrective measures and adjustments made to achieve desired results.

3.25 DDC SYSTEM VALIDATION TESTS

- A. Perform validation tests before requesting final review of system. Before beginning testing, first submit Pretest Checklist and Test Plan.
- B. After review of Pretest Checklist and Test Plan, execute all tests and procedures indicated in plan.
- C. After testing is complete, submit completed Pretest Checklist.
- D. Pretest Checklist: Submit the following list with items checked off once verified:
 - 1.Detailed explanation for any items that are not completed or verified.

2. Required mechanical installation work is successfully completed and HVAC equipment is working correctly.
3. HVAC equipment motors operate below full-load amperage ratings.
4. Required DDC system components, wiring, and accessories are installed.
5. Installed DDC system architecture matches approved Drawings.
6. Control electric power circuits operate at proper voltage and are free from faults.
7. Required surge protection is installed.
8. DDC system network communications function properly, including uploading and downloading programming changes.
9. Using BACnet protocol analyzer, verify that communications are error free.
10. Each controller's programming is backed up.
11. Equipment, products, tubing, wiring cable, and conduits are properly labeled.
12. All I/O points are programmed into controllers.
13. Testing, adjusting, and balancing work affecting controls is complete.
14. Dampers and actuators zero and span adjustments are set properly.
15. Each control damper and actuator goes to failed position on loss of power and loss of signal.
16. Valves and actuators zero and span adjustments are set properly.
17. Each control valve and actuator goes to failed position on loss of power and loss of signal.
18. Meter, sensor, and transmitter readings are accurate and calibrated.
19. Control loops are tuned for smooth and stable operation.
20. View trend data where applicable.
21. Each controller works properly in standalone mode.
22. Safety controls and devices function properly.
23. Interfaces with fire-alarm system function properly.
24. Electrical interlocks function properly.
25. Operator workstations and other interfaces are delivered, all system and database software is installed, and graphics are created.
26. Record Drawings are completed.

E. Test Plan:

1. Prepare and submit validation Test Plan including test procedures for performance validation tests.
2. Address all specified functions of DDC system and sequences of operation in Test Plan.
3. Explain detailed actions and expected results to demonstrate compliance with requirements indicated.
4. Explain method for simulating necessary conditions of operation used to demonstrate performance.
5. Include Test Checklist to be used to check and initial that each test has been successfully completed.
6. Submit Test Plan documentation 10 business days before start of tests.

F. Validation Test:

1. Verify operating performance of each I/O point in DDC system.
 - a. Verify analog I/O points at operating value.
 - b. Make adjustments to out-of-tolerance I/O points.

- 1) Identify I/O points for future reference.
 - 2) Simulate abnormal conditions to demonstrate proper function of safety devices.
 - 3) Replace instruments and controllers that cannot maintain performance indicated after adjustments.
2. Simulate conditions to demonstrate proper sequence of control.
 3. Readjust settings to design values and observe ability of DDC system to establish desired conditions.
 4. 24 hours after initial validation test, do as follows:
 - a. Re-check I/O points that required corrections during initial test.
 - b. Identify I/O points that still require additional correction and make corrections necessary to achieve desired results.
 5. 24 Hours after second validation test, do as follows:
 - a. Re-check I/O points that required corrections during second test.
 - b. Continue validation testing until I/O point is normal on two consecutive tests.
 6. Completely check out, calibrate, and test all connected hardware and software to ensure that DDC system performs according to requirements indicated.
 7. After validation testing is complete, prepare and submit report indicating results of testing. For all I/O points that required correction, indicate how many validation re-tests it took to pass. Identify adjustments made for each test and indicate instruments that were replaced.

G. DDC System Response Time Test:

1. Simulate HLC.
 - a. Heavy load to be occurrence of 50 percent of total connected binary COV, one-half of which represents "alarm" condition, and 50 percent of total connected analog COV, one-half of which represents "alarm" condition, that are initiated simultaneously on a one-time basis.
2. Initiate 10 successive occurrences of HLC and measure response time to typical alarms and status changes.
3. Measure with timer having at least 0.1-second resolution and 0.01 percent accuracy.
4. Purpose of test is to demonstrate DDC system, as follows:
 - a. Reaction to COV and alarm conditions during HLC.
 - b. Ability to update DDC system database during HLC.
5. Passing test is contingent on the following:
 - a. Alarm reporting at printer beginning no more than two seconds after initiation (time zero) of HLC.
 - b. All alarms, both binary and analog, are reported and printed; none are lost.
 - c. Compliance with response times specified.

6. Prepare and submit report documenting HLC tested and results of test including time stamp and print out of all alarms.

H. DDC System Network Bandwidth Test:

1. Test network bandwidth usage on all DDC system networks to demonstrate bandwidth usage under DDC system normal operating conditions and under simulated HLC.
2. To pass, none of DDC system networks are to use more than 70 percent of available bandwidth under normal and HLC operation.

3.26 FINAL REVIEW

- A. Submit written request to Architect when DDC system is ready for final review. State the following:
1. DDC system has been thoroughly inspected for compliance with Contract Documents and found to be in full compliance.
 2. DDC system has been calibrated, adjusted, and tested and found to comply with requirements of operational stability, accuracy, speed, and other performance requirements indicated.
 3. DDC system monitoring and control of HVAC systems results in operation according to sequences of operation indicated.
 4. DDC system is complete and ready for final review.
- B. Upon receipt of written request for final review, Architect to start review within reasonable period and upon completion issue field report(s) documenting observations and deficiencies.
- C. Take prompt action to remedy deficiencies indicated in reviewer's field report(s) and submit second written request after all deficiencies have been corrected. Repeat process until no deficiencies are reported.
- D. Compensation for Subsequent Reviews: Should more than two reviews be required, DDC system manufacturer and Installer to compensate entity/entities performing reviews for total costs (labor and expenses) associated with subsequent reviews. Estimated cost of each subsequent review to be submitted and approved by DDC system manufacturer and Installer before review.
- E. Prepare and submit closeout submittals and begin procedures indicated in "Extended Operation Test" Article when no deficiencies are reported.
- F. Part of DDC system final review to include demonstration to parties participating in final review.
1. Provide staff familiar with DDC system installed to demonstrate operation of DDC system during final review.
 2. Provide testing equipment to demonstrate accuracy and other performance requirements of DDC system that is requested by reviewers during final review.
 3. Demonstration to include, but not be limited to, the following:

- a. Accuracy and calibration of 10 I/O points randomly selected by reviewers. If review finds that some I/O points are not properly calibrated and not satisfying performance requirements indicated, additional I/O points may be selected by reviewers until total I/O points being reviewed that satisfy requirements equals quantity indicated.
- b. HVAC equipment and system hardwired and software safeties and life-safety functions are operating according to sequence of operation. Up to 10 I/O points to be randomly selected by reviewers. Additional I/O points may be selected by reviewers to discover problems with operation.
- c. Correct sequence of operation after electrical power interruption and resumption after electrical power is restored for randomly selected HVAC systems.
- d. Operation of randomly selected dampers and valves in normal-on, normal-off, and failed positions.
- e. Reporting of alarm conditions for randomly selected alarms, including different classes of alarms, to ensure that alarms are properly received by operators and operator workstations.
- f. Trends, summaries, logs, and reports set up for Project.
- g. For up to three HVAC systems randomly selected by reviewers, use graph trends to show that sequence of operation is executed in correct manner and that HVAC systems operate properly through complete sequence of operation including different modes of operations indicated. Show that control loops are stable and operating at set points and respond to changes in set point of 20 percent or more.
- h. Software's ability to communicate with controllers, operator workstations, and uploading and downloading of control programs.
- i. Software's ability to edit control programs offline.
- j. Data entry to show Project-specific customizing capability including parameter changes.
- k. Step through penetration tree, display all graphics, demonstrate dynamic update, and direct access to graphics.
- l. Execution of digital and analog commands in graphic mode.
- m. Spreadsheet and curve plot software and its integration with database.
- n. Online user guide and help functions.
- o. Multitasking by showing different operations occurring simultaneously on four quadrants of split screen.
- p. System speed of response compared to requirements indicated.
- q. For Each Controller: Applies to network and programmable application controllers.
 - 1) Memory: Programmed data, parameters, trend, and alarm history collected during normal operation are not to be lost during power failure.
 - 2) Operator Interface: Ability to connect directly to each type of digital controller with portable workstation and mobile device. Show that maintenance personnel interface tools perform as indicated in manufacturer's technical literature.
 - 3) Standalone Ability: Demonstrate that controllers provide stable and reliable standalone operation using default values or other method for values normally read over network.
 - 4) Electric Power: Ability to disconnect any controller safely from its power source.
 - 5) Wiring Labels: Match control drawings.
 - 6) Network Communication: Ability to locate controller's location on network and communication architecture matches Shop Drawings.

- 7) Nameplates and Tags: Accurate and permanently attached to control panel doors, instrument, actuators, and devices.
- r. For Each Operator Workstation:
- 1) I/O points lists agree with naming conventions.
 - 2) Graphics are complete.
 - 3) UPS unit, if applicable, operates.
- s. Communications and Interoperability: Demonstrate proper interoperability of data sharing, alarm and event management, trending, scheduling, and device and network management. Use ASHRAE 135 protocol analyzer to help identify devices, view network traffic, and verify interoperability. Requirements must be met even if only one manufacturer's equipment is installed.
- 1) Data Presentation: On each operator workstation, demonstrate graphic display capabilities.
 - 2) Reading of Any Property: Demonstrate ability to read and display any used readable object property of any device on network.
 - 3) Set-Point and Parameter Modifications: Show ability to modify set points and tuning parameters indicated. Modifications are made with messages and write services initiated by operator using workstation graphics, or by completing a field in menu with instructional text.
 - 4) Peer-to-Peer Data Exchange: Network devices are installed and configured to perform without need for operator intervention to implement Project sequence of operation and to share global data.
 - 5) Alarm and Event Management: Alarms and events are installed and prioritized according to Owner. Demonstrate that time delays and other logic are set up to avoid nuisance tripping. Show that operators with sufficient privileges are permitted.
 - 6) Schedule Lists: Schedules are configured for start and stop, mode change, occupant overrides, and night setback as defined in sequence of operations.
 - 7) Schedule Display and Modification: Ability to display any schedule with start and stop times for calendar year. Show that all calendar entries and schedules are modifiable from any connected operator workstation by an operator with sufficient privilege.
 - 8) Archival Storage of Data: Data archiving is handled by operator workstation and server and local trend archiving and display is accomplished.
 - 9) Modification of Trend Log Object Parameters: Operator with sufficient privilege can change logged data points, sampling rate, and trend duration.
 - 10) Device and Network Management:
 - a) Display of network device status.
 - b) Display of BACnet object information.
 - c) Silencing devices transmitting erroneous data.
 - d) Time synchronization.
 - e) Remote device re-initialization.
 - f) Backup and restore network device programming and master database(s).
 - g) Configuration management of routers.

3.27 EXTENDED OPERATION TEST

- A. Operate DDC system for operating period of 21 consecutive calendar days following Final Acceptance. Coordinate exact start date of testing with Owner.
- B. Provide operator familiar with DDC system installed to man an operator workstation while on-site during eight hours of each normal business day occurring during operating period.
- C. During operating period, DDC system to demonstrate correct operation and accuracy of monitored and controlled points as well as operation capabilities of sequences, logs, trends, reports, specialized control algorithms, diagnostics, and other software indicated.
 - 1. Correct defects of hardware and software when they occur.
- D. Definition of Failures and Downtime during Operating Period:
 - 1. Failed I/O point constituting downtime is I/O point failing to perform its intended function consistently and a point physically failed due to hardware and software.
 - 2. Downtime is when any I/O point in DDC system is unable to fulfill its required function.
 - 3. Calculate downtime as elapsed time between detected point failure as confirmed by operator, and time point is restored to service.
 - 4. Maximum time interval allowed between DDC system detection of failure occurrence and operator confirmation is to be 0.5 hours.
 - 5. Log downtime in hours to nearest 0.1 hour.
 - 6. Power outages do not count as downtime, but do suspend test hours unless systems are provided with UPS and served through a backup power source.
 - 7. Hardware or software failures caused by power outages do count as downtime.
- E. During operating period, log downtime and operational problems are encountered.
 - 1. Identify source of problem.
 - 2. Provide written description of corrective action taken.
 - 3. Record duration of downtime.
 - 4. Maintain log showing the following:
 - a. Time of occurrence.
 - b. Description of each occurrence and pertinent written comments for reviewer to understand scope and extent of occurrence.
 - c. Downtime for each failed I/O point.
 - d. Running total of downtime and total time of I/O point after each problem has been restored.
 - 5. Make log available to Owner for review at any time.
- F. For DDC system to pass extended operation test, total downtime is limited to 2 percent of total point-hours during operating period.
 - 1. If DDC system testing results fail to comply with minimum requirements of passing at end of operating period indicated, extend operating period one consecutive day at a time until DDC system passes requirement.

G. Base evaluation of DDC system passing test on the following calculation:

1. Count downtime on point-hour basis where total number of DDC system point-hours is equal to total number of I/O points in DDC system multiplied by total number of hours during operating period.
2. One point-hour of downtime is one I/O point down for one hour. For example, three I/O points down for five hours is total of 15 point-hours of downtime. Four points down for one-half hour is two point-hours of downtime.
3. Example Calculation: Maximum allowable downtime for 30-day test for DDC system with 1000 total I/O points (combined analog and binary) and passing score of 1 percent downtime is computed by 30 days x 24 h/day x 1000 points x 1 percent equals 7200 point-hours of maximum allowable downtime.

H. Prepare test and inspection reports.

3.28 ADJUSTING

- A. Occupancy Adjustments: When requested within 12 months from date of Final Acceptance, provide on-site assistance in adjusting system to suit actual occupied conditions. Provide up to two visits to Project during other-than-normal occupancy hours for this purpose.

3.29 MAINTENANCE SERVICE

- A. Beginning at Final Acceptance, verify that maintenance service includes six months' full maintenance by DDC system manufacturer's authorized service representative. Include quarterly preventive maintenance, repair or replacement of worn or defective components, cleaning, calibration, and adjusting as required for proper operation. Use only manufacturer's authorized replacement parts and supplies.

3.30 SOFTWARE SERVICE AGREEMENT

- A. Technical Support: Beginning at Final Acceptance, verify that service agreement includes software support for two year(s).
- B. Upgrade Service: At Final Acceptance, update software to latest version. Install and program software upgrades that become available within two year(s) from date of Final Acceptance. Verify that upgrading software includes operating system and new or revised licenses for using software.
 1. Upgrade Notice: No fewer than 30 days to allow Owner to schedule and access system and to upgrade computer equipment if necessary.

3.31 DEMONSTRATION

- A. Engage a factory-authorized service representative with complete knowledge of Project-specific system installed to train Owner's maintenance personnel to adjust, operate, and maintain DDC system.

B. Extent of Training:

1. Base extent of training on scope and complexity of DDC system indicated and training requirements indicated. Provide extent of training required to satisfy requirements indicated even if more than minimum training requirements are indicated.
2. Inform Owner of anticipated training requirements if more than minimum training requirements are indicated.
3. Minimum Training Requirements:
 - a. Provide not less than 10 days of training total.
 - b. Stagger training over multiple training classes to accommodate Owner's requirements. All training to occur before end of warranty period.
 - c. Break down total days of training into not more than three separate training classes.
 - d. Schedule training so each training class is not less than two consecutive day(s).

C. Training Schedule:

1. Schedule training with Owner 20 business days before expected Final Acceptance.
2. Schedule training to provide Owner with at least 15 business days of notice in advance of training.
3. Training to occur within normal business hours at mutually agreed on time. Unless otherwise agreed to, training to occur Monday through Friday, except on U.S. Federal holidays, with two morning sessions and two afternoon sessions. Each morning session and afternoon session to be split in half with 30-minute break between sessions. Morning and afternoon sessions to be separated by 30-minute lunch period. Training, including breaks and excluding lunch period, are not to exceed eight hours per day.
4. Provide staggered training schedule as requested by Owner.

D. Training Attendee List and Sign-in Sheet:

1. Request from Owner in advance of training a proposed attendee list with name, phone number, and email address.
2. Provide preprinted sign-in sheet for each training session with proposed attendees listed and no fewer than six blank spaces to add additional attendees.
3. Include preprinted sign-in sheet with training session number, date and time, instructor name, phone number, email address, and brief description of content to be covered during session. List attendees with columns for name, phone number, and email address and a column for attendee signature or initials.
4. Circulate sign-in sheet at beginning of each session and solicit attendees to sign or initial in applicable location.
5. At end of each training day, send Owner an email with attachment of scanned copy (PDF) of circulated sign-in sheet for each session. Indicate which attendees, if any, joined for only part of training sessions.

E. Training Attendee Headcount:

1. Plan in advance of training for three attendees.
2. Make allowance for Owner to add up to two attendee(s) at time of training.
3. Headcount may vary depending on training content covered in session. Attendee access may be restricted to some training content for purposes of maintaining system security.

- F. Training Attendee Prior Knowledge: For guidance in planning required training and instruction, assume attendees have the following:
1. Intermediate user knowledge of computers and office applications.
 2. Intermediate knowledge of HVAC systems.
 3. Intermediate knowledge of DDC systems.
 4. Intermediate knowledge of DDC system and products installed.
- G. Attendee Training Manuals:
1. Provide each attendee with color hard copy of all training materials and visual presentations.
 2. Organize hard-copy materials in three-ring binder with table of contents and individual divider tabs marked for each logical grouping of subject matter. Organize material to provide space for attendees to take handwritten notes within training manuals.
 3. In addition to hard-copy materials included in training manual, provide each binder with a sleeve or pocket that includes DVD or flash drive with PDF copy of all hard-copy materials.
- H. Instructor Requirements:
1. One or multiple qualified instructors, as required, to provide training.
 2. Use instructors who have provided not less than five years of instructional training on not less than five past projects with similar DDC system scope and complexity to DDC system installed.
- I. Organization of Training Sessions:
1. Organize training sessions into logical groupings of technical content and to reflect different levels of operators having access to system. Plan training sessions to accommodate the following three levels of operators:
 - a. Daily operators.
 - b. Advanced operators.
 - c. System managers and administrators.
 2. Plan and organize training sessions to group training content to protect DDC system security. Some attendees may be restricted to some training sessions to ensure DDC system security.
- J. Training Outline:
1. Submit training outline for Owner review at least 10 business day before scheduling training.
 2. Include in outline a detailed agenda for each training day that is broken down into each of four training sessions that day, training objectives for each training session, and synopses for each lesson planned.
- K. On-Site Training:
1. Owner will provide conditioned classroom or workspace with ample desks or tables, chairs, power, and data connectivity for instructor and each attendee.
 2. Provide training materials, projector, and other audiovisual equipment used in training.
 3. Provide as much of training located on-site as deemed feasible and practical by Owner.

4. Include on-site training with regular walk-through tours, as required, to observe each unique product type installed with hands-on review of operation, calibration, and service requirements.
5. Use operator workstation that is to be used with DDC system in the training. If operator workstations are unavailable, provide temporary workstation to convey training content.

L. Off-Site Training:

1. Provide conditioned training rooms and workspace with ample tables desks or tables, chairs, power, and data connectivity for each attendee.
2. Provide capability to remotely access to Project DDC system for use in training.
3. Provide operator workstation for use by each attendee.

M. Training Content for Daily Operators:

1. Basic operation of system.
2. Understanding DDC system architecture and configuration.
3. Understanding each unique product type installed including performance and service requirements for each.
4. Understanding operation of each system and equipment controlled by DDC system including sequences of operation, each unique control algorithm, and each unique optimization routine.
5. Operating operator workstations, printers, and other peripherals.
6. Logging on and off system.
7. Accessing graphics, reports, and alarms.
8. Adjusting and changing set points and time schedules.
9. Recognizing DDC system malfunctions.
10. Understanding content of operation and maintenance manuals including control drawings.
11. Understanding physical location and placement of DDC controllers and I/O hardware.
12. Accessing data from DDC controllers.
13. Operating portable operator workstations.
14. Review of DDC testing results to establish basic understanding of DDC system operating performance and HVAC system limitations as of Final Acceptance.
15. Running each specified report and log.
16. Displaying and demonstrating each data entry to show Project-specific customizing capability. Demonstrating parameter changes.
17. Stepping through graphics penetration tree, displaying all graphics, demonstrating dynamic updating, and direct access to graphics.
18. Executing digital and analog commands in graphic mode.
19. Demonstrating control loop precision and stability via trend logs of I/O for not less than 10 percent of I/O installed.
20. Demonstrating DDC system performance through trend logs and command tracing.
21. Demonstrating scan, update, and alarm responsiveness.
22. Demonstrating spreadsheet and curve plot software, and its integration with database.
23. Demonstrating on-line user guide, and help function and mail facility.
24. Demonstrating multitasking by showing dynamic curve plot, and graphic construction operating simultaneously via split screen.
25. Demonstrating the following for HVAC systems and equipment controlled by DDC system:

- a. Operation of HVAC equipment in normal-off, normal-on, and failed conditions while observing individual equipment, dampers, and valves for correct position under each condition.
- b. For HVAC equipment with factory-installed software, show that integration into DDC system is able to communicate with DDC controllers or gateways, as applicable.
- c. Using graphed trends, show that sequence of operation is executed in correct manner, and HVAC systems operate properly through complete sequence of operation including seasonal change, occupied and unoccupied modes, warm-up and cool-down cycles, and other modes of operation indicated.
- d. Hardware interlocks and safeties function properly and DDC system performs correct sequence of operation after electrical power interruption and resumption after power is restored.
- e. Reporting of alarm conditions for each alarm, and confirm that alarms are received at assigned locations, including operator workstations.
- f. Each control loop responds to set-point adjustment and stabilizes within time period indicated.
- g. Sharing of previously graphed trends of all control loops to demonstrate that each control loop is stable and set points are being maintained.

N. Training Content for Advanced Operators:

1. Making and changing workstation graphics.
2. Creating, deleting, and modifying alarms including annunciation and routing.
3. Creating, deleting, and modifying point trend logs including graphing and printing on an ad-hoc basis and operator-defined time intervals.
4. Creating, deleting, and modifying reports.
5. Creating, deleting, and modifying points.
6. Creating, deleting, and modifying programming including ability to edit control programs offline.
7. Creating, deleting, and modifying system graphics and other types of displays.
8. Adding DDC controllers and other network communication devices such as gateways and routers.
9. Adding operator workstations.
10. Performing DDC system checkout and diagnostic procedures.
11. Performing DDC controllers operation and maintenance procedures.
12. Performing operator workstation operation and maintenance procedures.
13. Configuring DDC system hardware including controllers, workstations, communication devices, and I/O points.
14. Maintaining, calibrating, troubleshooting, diagnosing, and repairing hardware.
15. Adjusting, calibrating, and replacing DDC system components.

O. Training Content for System Managers and Administrators:

1. DDC system software maintenance and backups.
2. Uploading, downloading, and offline archiving of all DDC system software and databases.
3. Interface with Project-specific, third-party operator software.
4. Understanding password and security procedures.
5. Adding new operators and making modifications to existing operators.
6. Operator password assignments and modification.
7. Operator authority assignment and modification.

8. Workstation data segregation and modification.

P. Video of Training Sessions:

1. Provide digital video and audio recording of each training session. Create separate recording file for each session.
2. Stamp each recording file with training session number, session name, and date.
3. Provide Owner with two copies of digital files on cloud and flash drives for later reference and for use in future training.
4. Owner retains right to make additional copies for intended training purposes without having to pay royalties.

END OF SECTION

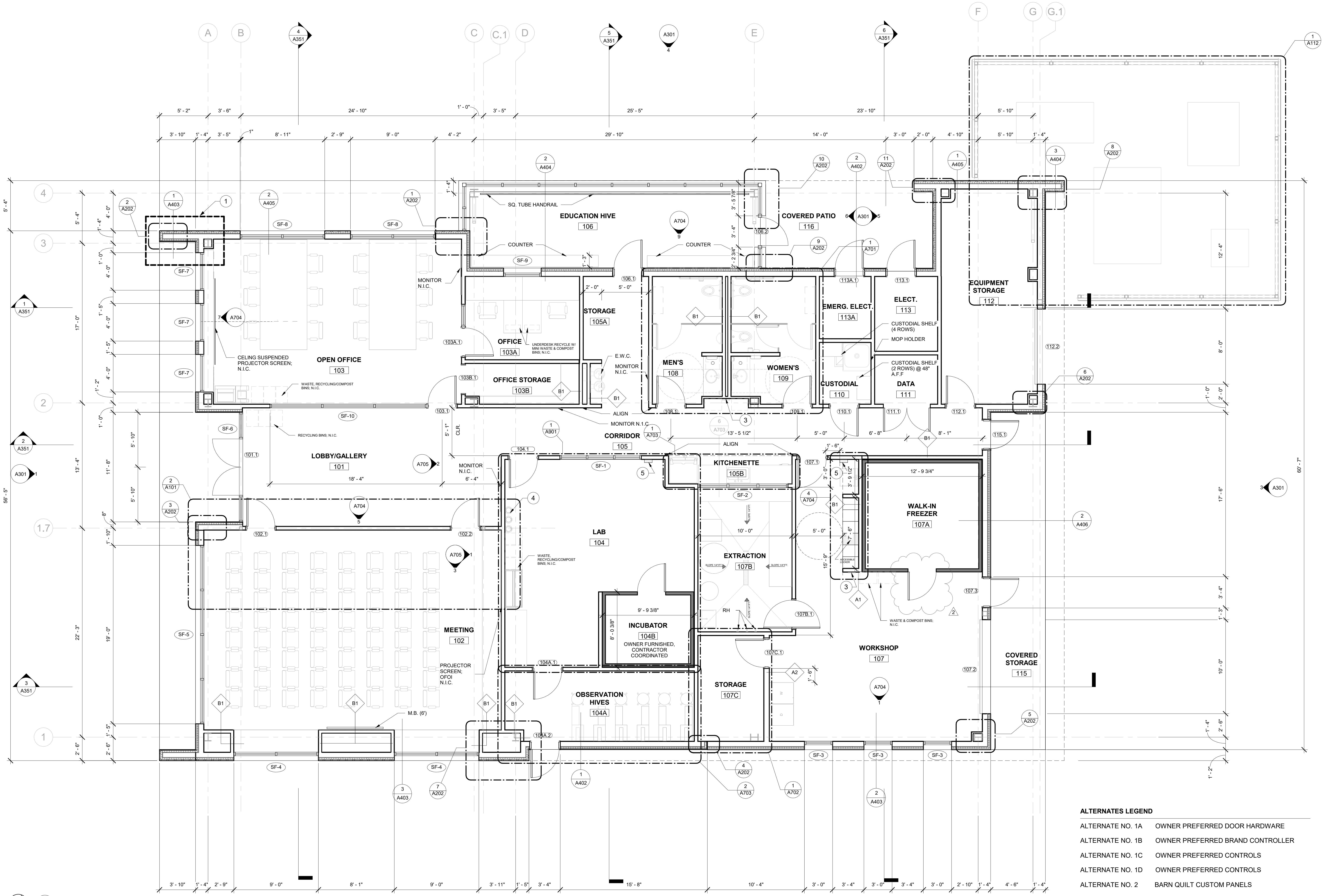

1 FLOOR PLAN - BASE BID
1/4" = 1'-0"

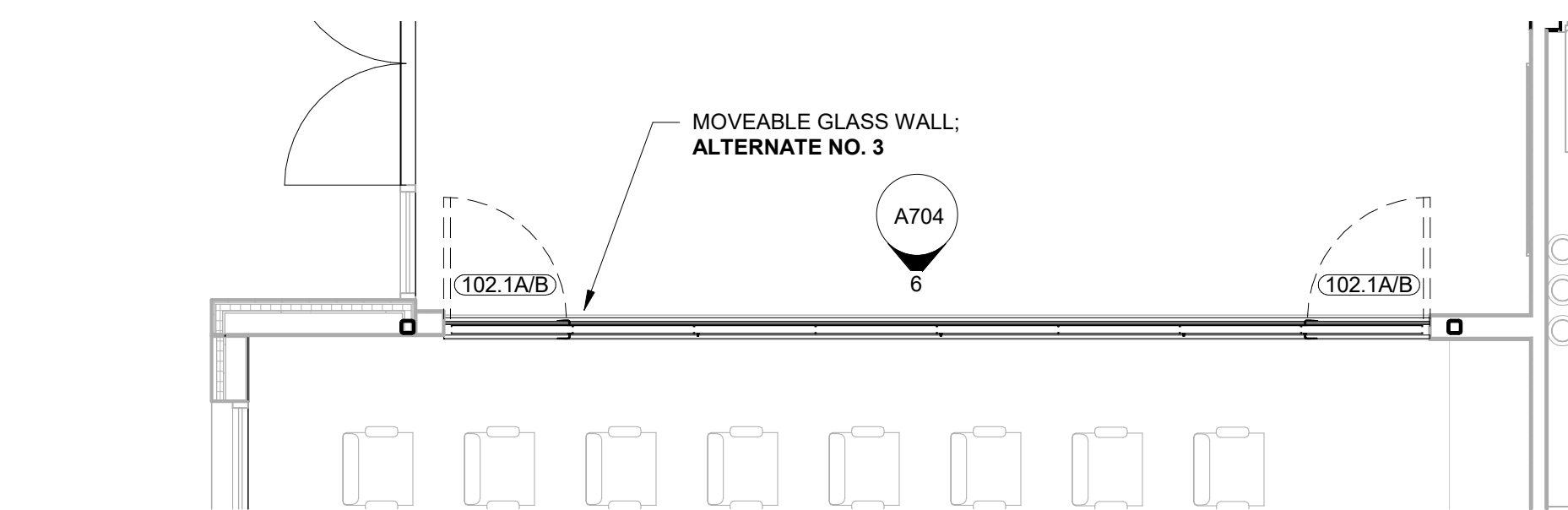

2 FLOOR PLAN - ALTERNATE NO. 3
1/4" = 1'-0"

GENERAL FLOOR PLAN NOTES

- DIMENSIONS ARE TO COLUMN CENTERLINES OR FINISH FACE OF PARTITION UNLESS OTHERWISE NOTED. SEE SHEET A201 FOR TYPES AND THICKNESSES.
- ALL PARTITION TYPES ARE TO BE "A1" UNLESS OTHERWISE NOTED. SEE SHEET A201 FOR TYPES AND THICKNESSES.
- SEE ENLARGED PLANS FOR PARTITION TYPES NOT SHOWN ON FLOOR PLAN.

GENERAL FLOOR PLAN LEGEND

(B1) PARTITION TYPE (SEE SHEET A201)

(101) DOOR NUMBER (SEE SHEET A251)

(SF-#) STOREFRONT TYPE

M.B. (#) MARKERBOARD (LENGTH)

NEW WORK KEYNOTES	
NUMBER	DESCRIPTION
1	INTEGRATED EXTERIOR MOCKUP TO INCLUDE WALL SYSTEM, FENESTRATION, FINISHES, ROOF AND SOFFIT
2	UNDER BASE BID, INFILL WITH 5/8" GYP. BD. ON 2 1/2" STUDS
3	RECESSED FIRE EXTINGUISHER CABINET
4	NEW WALL MOUNT CYLINDER RACK (USA SAFETY # GB401FS OR APPROVED EQUAL)
5	GLOVE DISPENSER

ALTERNATES LEGEND

ALTERNATE NO. 1A	OWNER PREFERRED DOOR HARDWARE
ALTERNATE NO. 1B	OWNER PREFERRED BRAND CONTROLLER
ALTERNATE NO. 1C	OWNER PREFERRED CONTROLS
ALTERNATE NO. 1D	OWNER PREFERRED CONTROLS
ALTERNATE NO. 2	BARN QUILT CUSTOM PANELS
ALTERNATE NO. 3	MOVEABLE GLASS WALL
ALTERNATE NO. 4	CERAMIC WALL TILE (BASE BID - HIGH PERFORMANCE COATING HPC-1)
ALTERNATE NO. 5	TOILET ROOM 107C (BASE BID - STORAGE ROOM 107C)
ALTERNATE NO. 6	EMERGENCY GENERATOR
ALTERNATE NO. 7	POLISHED CONCRETE (BASE BID - UNPOLISHED CONCRETE)
ALTERNATE NO. 8	FRP AND PVC ROLL PRODUCT FLOORING (BASE BID - HIGH PERFORMANCE COATING HPC-1 AND UNPOLISHED CONCRETE FLOOR CON-1)
ALTERNATE NO. 9	AHU SCREENING (BASE BID- OMIT SCREENING)
ALTERNATE NO. 10	EXISTING HOUSE & SEPTIC DEMOLITION
ALTERNATE NO. 11	LAB CASEWORK (BASE BID - OMIT LAB CASEWORK)

biloba Architecture, PLLC
 think design
 8801 JM Keynes Drive
 Suite 365
 Charlotte, NC 28262
 704.248.2922
 www.biloba.co

Civil and Structural Engineer, Landscape Architect:
 Stewart Inc.
 Raleigh 223 S. West Street, Suite 1100
 Raleigh, NC 27603
 NC Certificate of Licensure: C-1051

Plumbing, Mechanical, and Electrical Engineer:
 RMF Engineering
 5520 Research Park Drive, Ste 300
 Baltimore, MD 21228
 NC Certificate of Licensure: C-1125

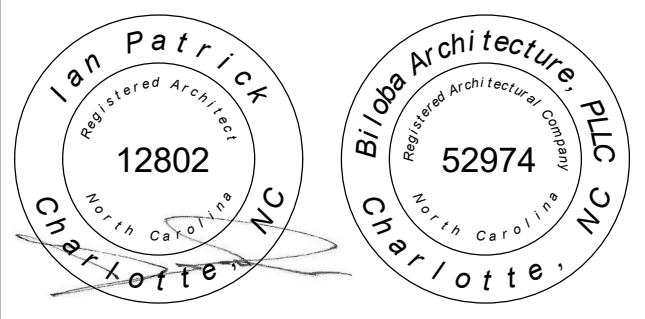

02.12.2025
 Drawn ELP
 Checked IWP
 Date 01/10/2025
 Revisions
 2 02/12/2025 Addendum No. 3

Copyright 2024. All rights reserved. Printed or electronic drawings and documentation may not be reproduced in any form without written permission from Biloba Architecture, PLLC.

NCSU Apiculture Facility
 Raleigh, NC
 SCO ID No.: 22-24494-01A
 Code: 42124 Item: 315
 NCSU: 202220007

Project Number 132
 Title
First Floor Plan

Sheet
A101
 Plate

DOOR SCHEDULE - BASE BID													
DOOR NO.	DOOR TYPE	DOOR MATERIAL	FIRE RATING	HARDWARE SET	DOOR WIDTH	DOOR HEIGHT	DOOR THICK	FRAME TYPE	FRAME MATERIAL	HEAD	JAMB	THOLD	COMMENTS
101.1	B	ALUM.	-	1	6'-0"	8'-0"	0' - 1 3/4"	SF-6	ALUM.			10/A251	
102.1	B	WD.	-	3	3'-0"	7'-0"	0' - 1 3/4"	F-1	H.M.	3/A251	8/A251		
102.1A/B	B	ALUM.	-	3	24'-4"	7'-0"	0' - 1 25/32"	-	ALUM.	3/A254			MEETING ROOM- STACKING DOOR ALTERNATE NO. 3
102.2	B	WD.	-	3	3'-0"	7'-0"	0' - 1 3/4"	F-1	H.M.	3/A251	8/A251		
103.1	B	WD.	-	5	3'-0"	7'-0"	0' - 1 3/4"	F-1	H.M.	3/A251	8/A251		
103A.1	C	WD.	-	6	3'-0"	7'-0"	0' - 1 3/4"	F-2	H.M.	3/A251	8/A251		
103B.1	-	-	-	-	3'-0"	7'-0"	0' - 1 3/4"	F-1	H.M.	3/A251	8/A251		CASED OPENING
104.1	B	WD.	-	5	3'-0"	7'-0"	0' - 1 3/4"	F-1	H.M.	3/A251	8/A251		
104A.1	D	WD.	-	7	3'-0"	7'-0"	0' - 1 3/4"	F-1	H.M.	3/A251	8/A251		
104A.2	D	H.M.	-	4	3'-0"	7'-0"	0' - 1 3/4"	F-1	H.M.	6/A251	14/A251		
104A.4					3'-0"	6'-2"	0' - 1 3/4"						
106.1	D	H.M.	-	4	3'-0"	7'-0"	0' - 1 3/4"	F-1	H.M.	4/A251	15/A251		
106.2	B	ALUM.	-	4	3'-0"	7'-0"	0' - 1 3/4"	F-1	ALUM.				
107.1	C	H.M.	-	5	3'-0"	7'-0"	0' - 1 3/4"	F-1	H.M.	3/A251	8/A251		
107.2	F	STEEL	-	-	10'-0"	8'-0"	0' - 3"	-	-	7/A251			OVERHEAD COILING DOOR
107.3	A	H.M.	-	4	3'-0"	7'-0"	0' - 1 3/4"	F-1	H.M.	4/A251	15/A251		
107B.1	D	STEEL	-	BY MANUF.	3'-0"	7'-0"	0' - 1 3/4"	F-1	STEEL	3/A251	8/A251		TRAFFIC DOOR
107C.1	A	H.M.	-	11	3'-0"	7'-0"	0' - 1 3/4"	F-1	H.M.	3/A251	8/A251		
108.1	A	WD.	-	8	3'-0"	7'-0"	0' - 1 3/4"	F-1	H.M.	11/A251	12/A251		
109.1	A	WD.	-	8	3'-0"	7'-0"	0' - 1 3/4"	F-1	H.M.	11/A251	12/A251		
110.1	A	WD.	-	9	3'-0"	7'-0"	0' - 1 3/4"	F-1	H.M.	3/A251	8/A251		
111.1	A	WD.	-	10	5'-0"	7'-0"	0' - 1 3/4"	F-1	H.M.	3/A251	8/A251		
112.1	A	WD.	-	5	3'-0"	7'-0"	0' - 1 3/4"	F-1	H.M.	3/A251	8/A251		
112.2	F	STEEL	-	-	8'-0"	8'-0"	0' - 3"	-	-	7/A251			OVERHEAD COILING DOOR
113.1	E	H.M.	-	4	3'-0"	7'-0"	0' - 1 3/4"	F-1	H.M.	6/A251	14/A251		
113A.1	E	H.M.	-	2B	3'-0"	7'-0"	0' - 1 3/4"	F-1	H.M.	6/A251	14/A251		
115.1	B	ALUM.	-	2A	3'-0"	7'-0"	0' - 1 3/4"	F-1	ALUM.			10/A251	

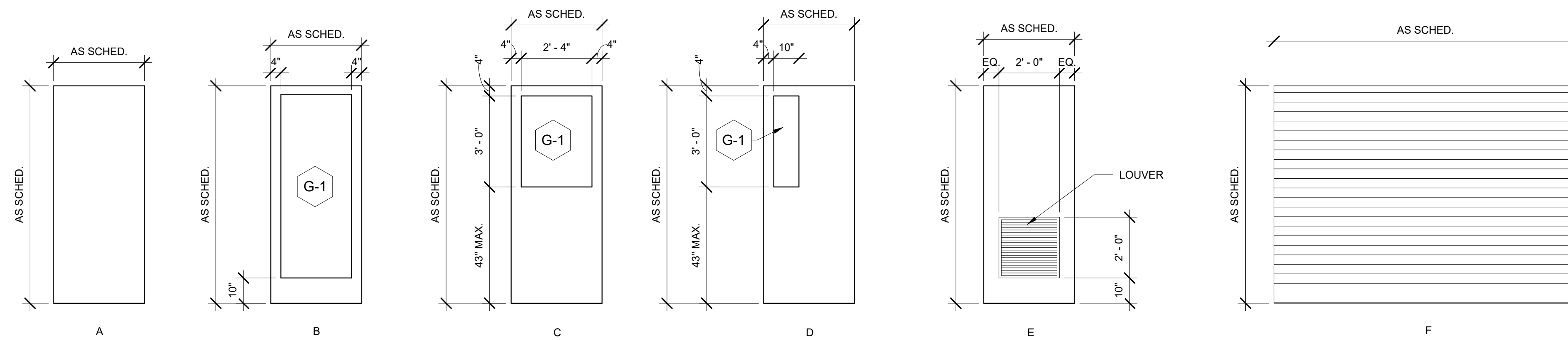

1 DOOR ELEVATIONS
A251 3/8" = 1'-0"

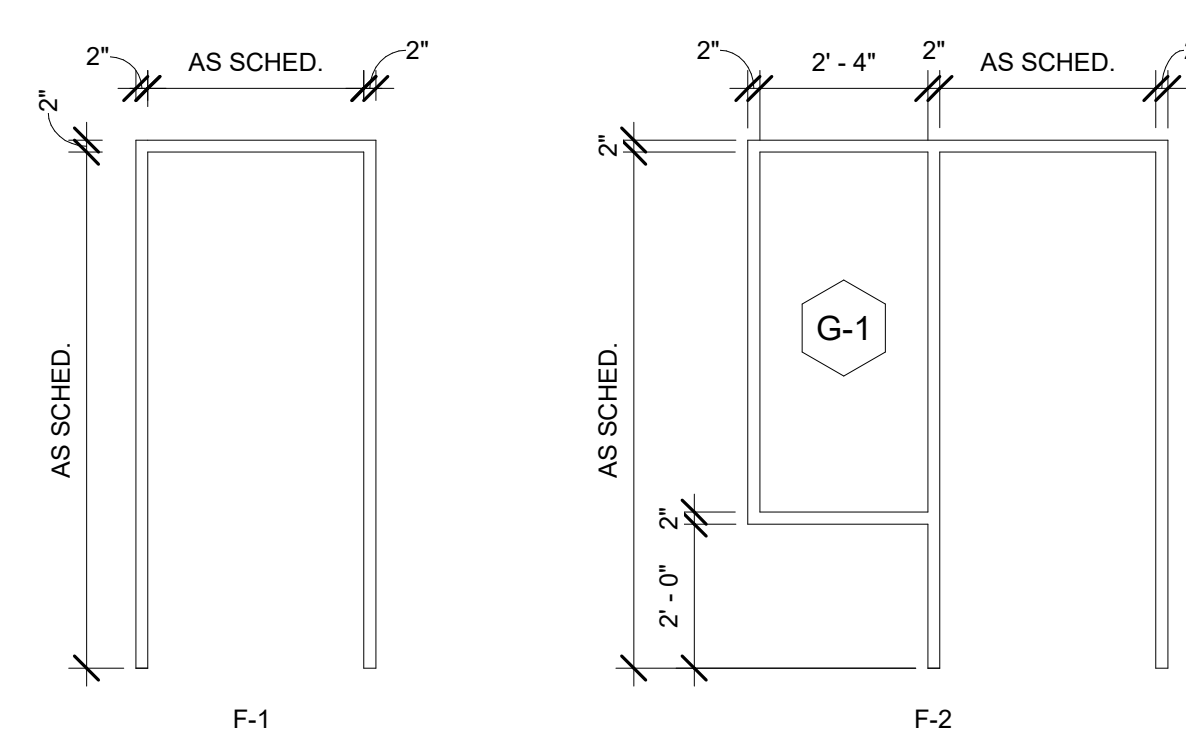

2 DOOR FRAME ELEVATIONS
A251 3/8" = 1'-0"

GLAZING SCHEDULE

G-1	1/4" CLEAR ANNEALED TEMPERED FLOAT GLASS
G-2	1" INSULATING GLAZING UNIT

SEE SPECIFICATIONS FOR MORE INFORMATION ON GLAZING TYPES

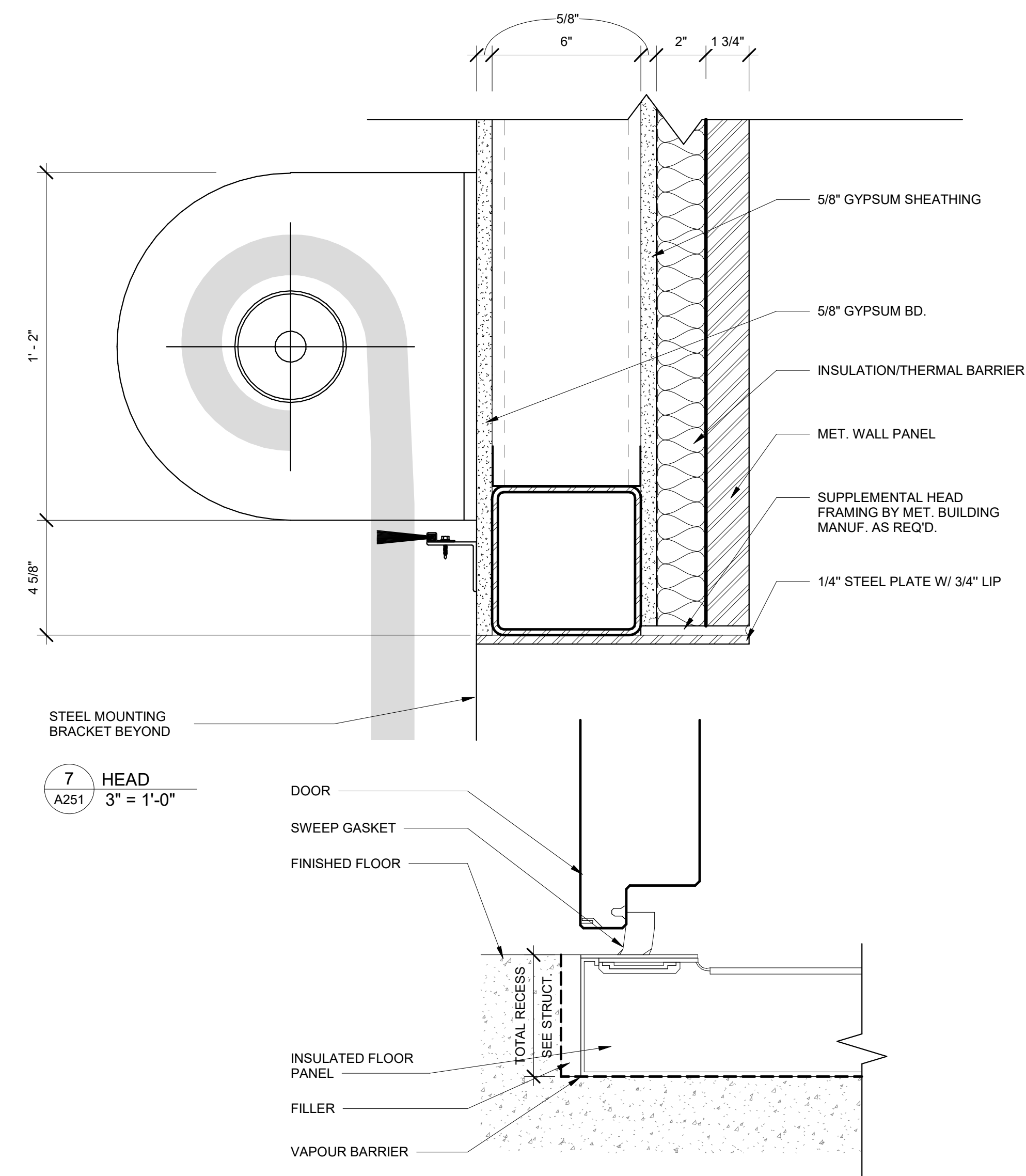

7 HEAD
A251 3" = 1'-0"

13 DETAIL- WALK IN FREEZER
A251 3" = 1'-0"

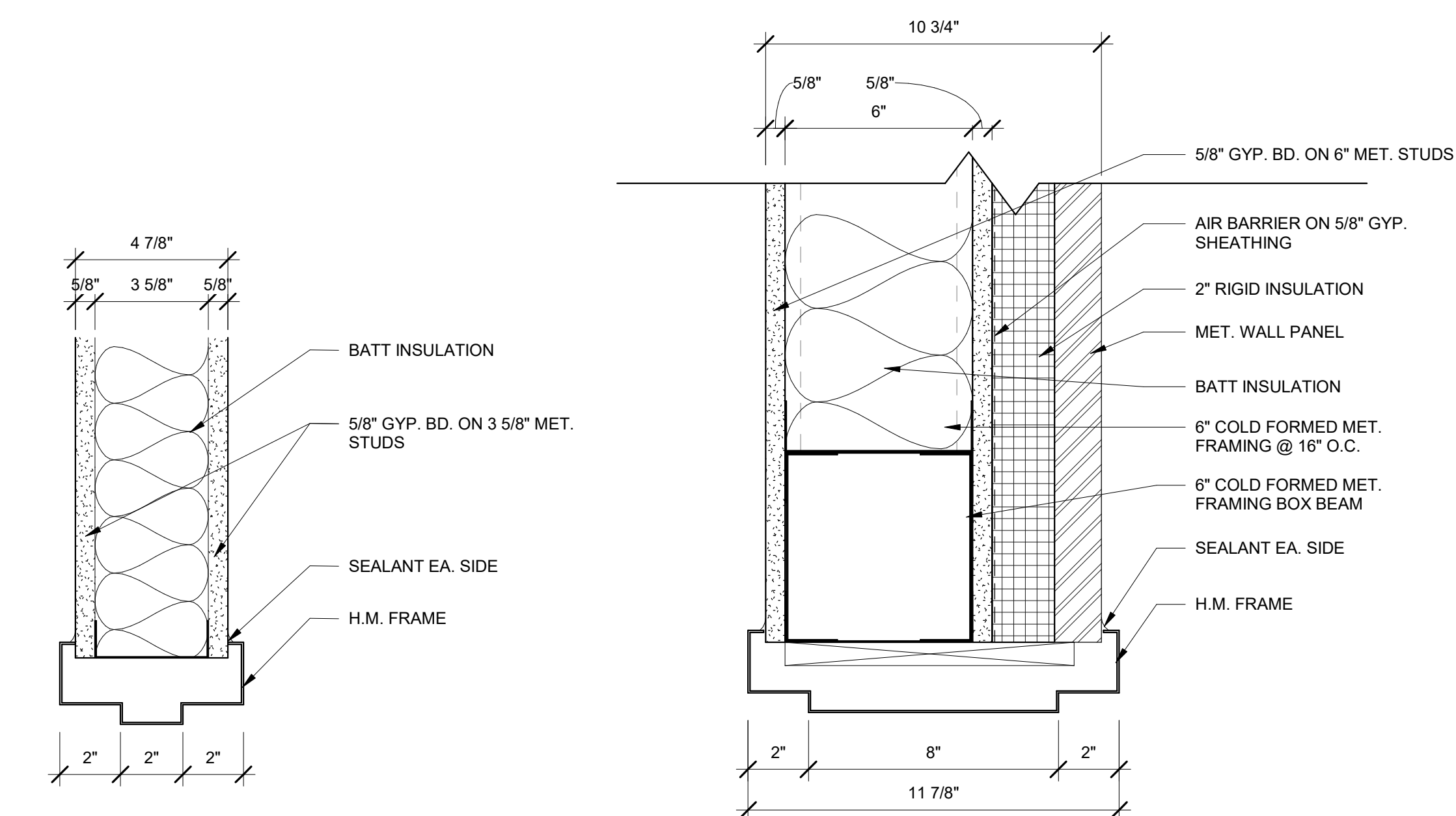

3 HEAD
A251 3" = 1'-0"

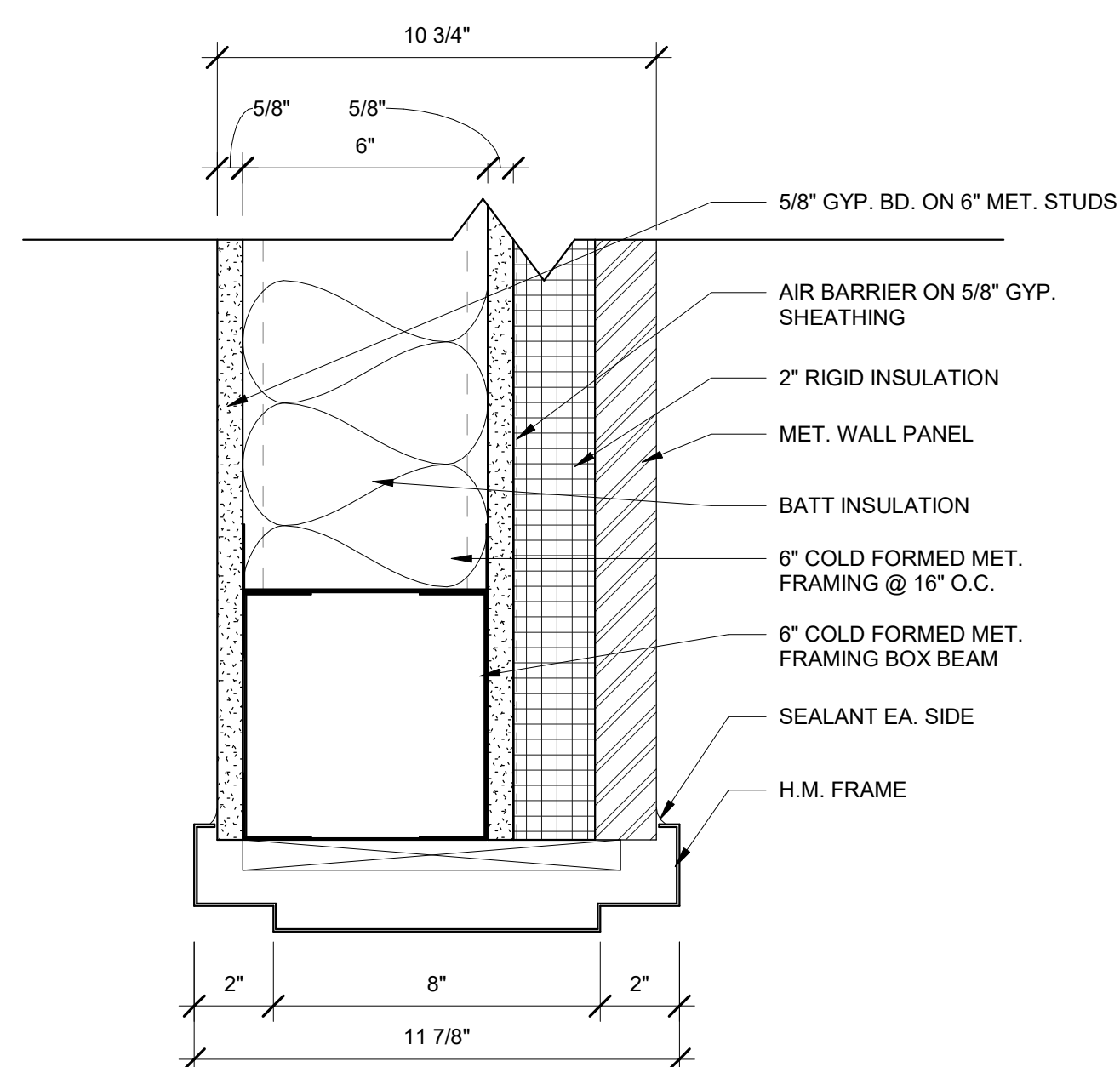

4 HEAD
A251 3" = 1'-0"

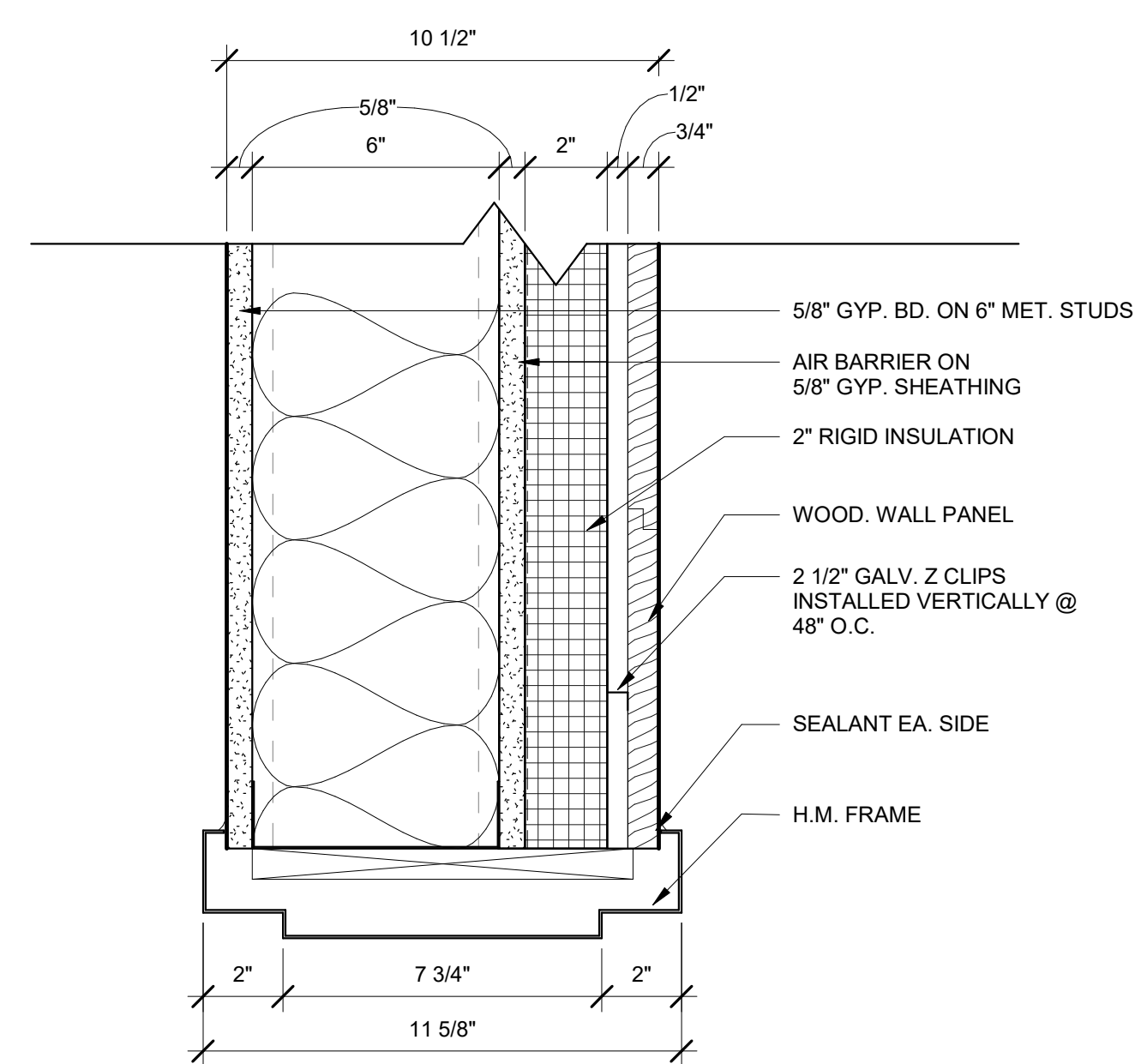

6 HEAD
A251 3" = 1'-0"

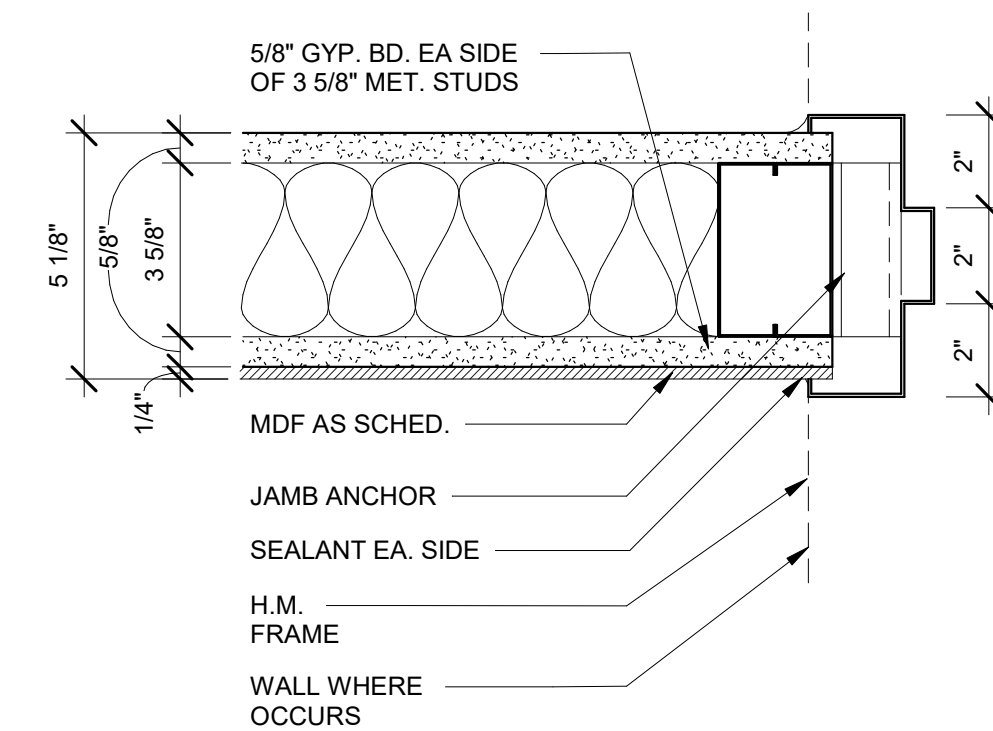

12 JAMB
A251 3" = 1'-0"

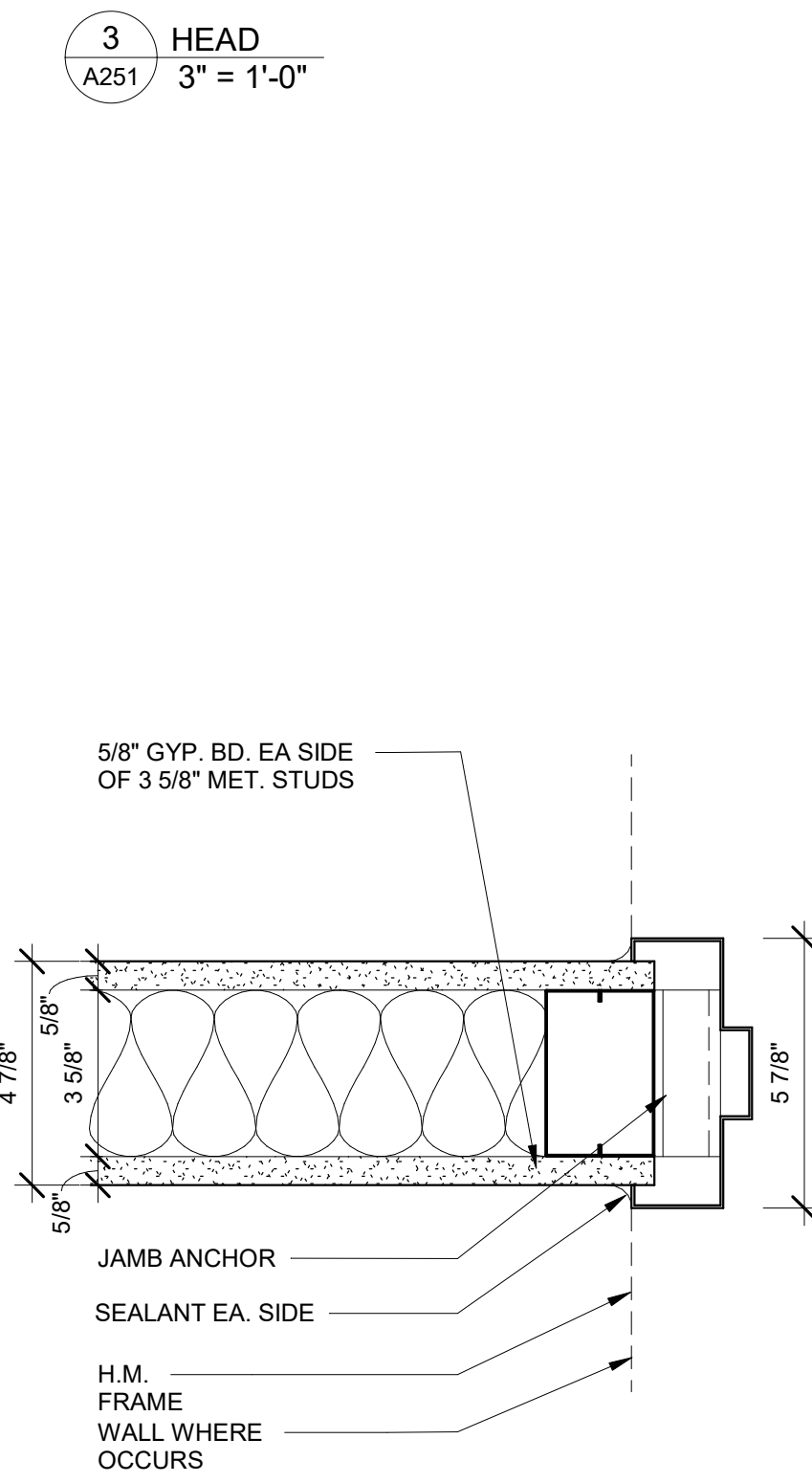

8 JAMB
A251 3" = 1'-0"

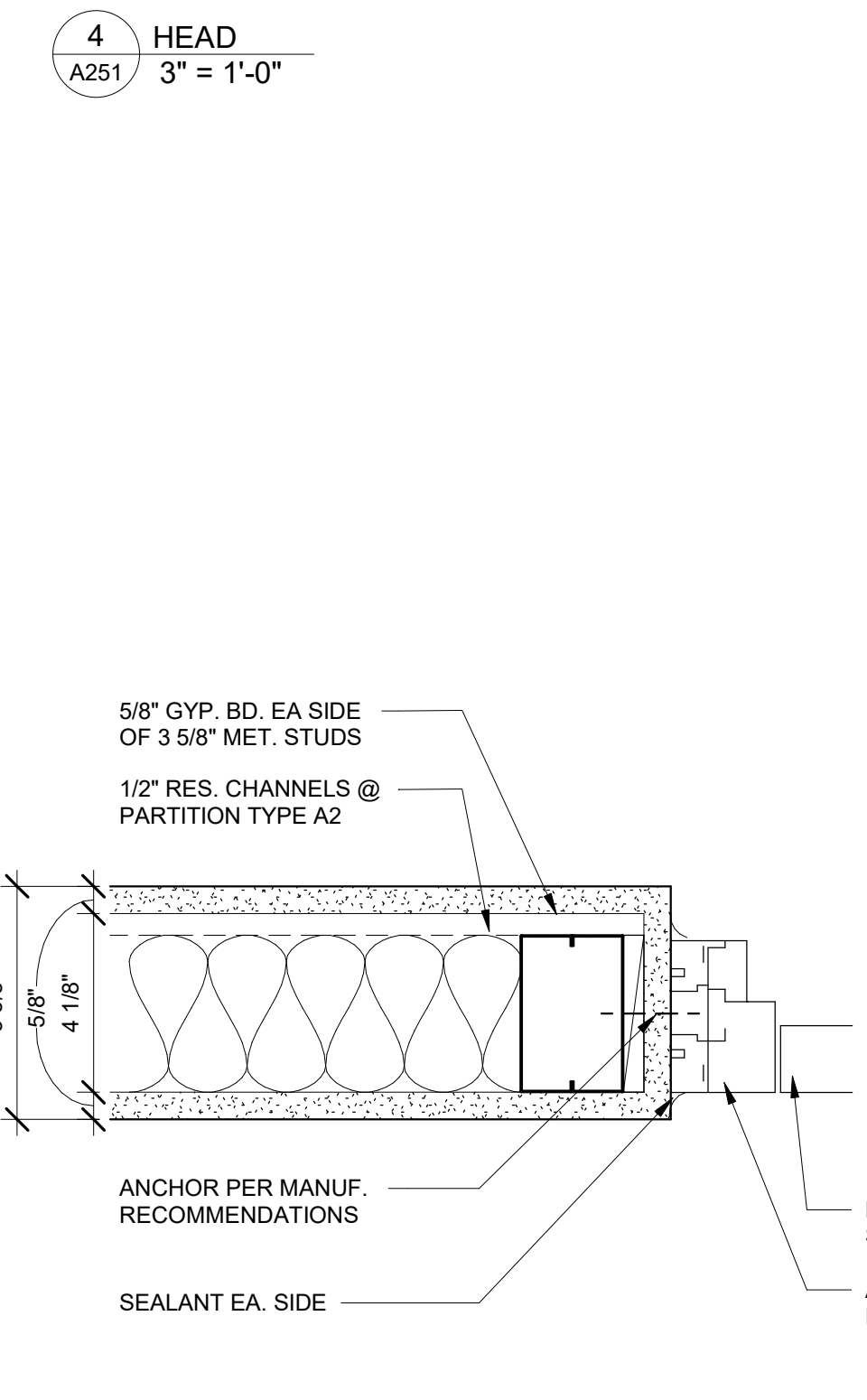

9 JAMB
A251 3" = 1'-0"

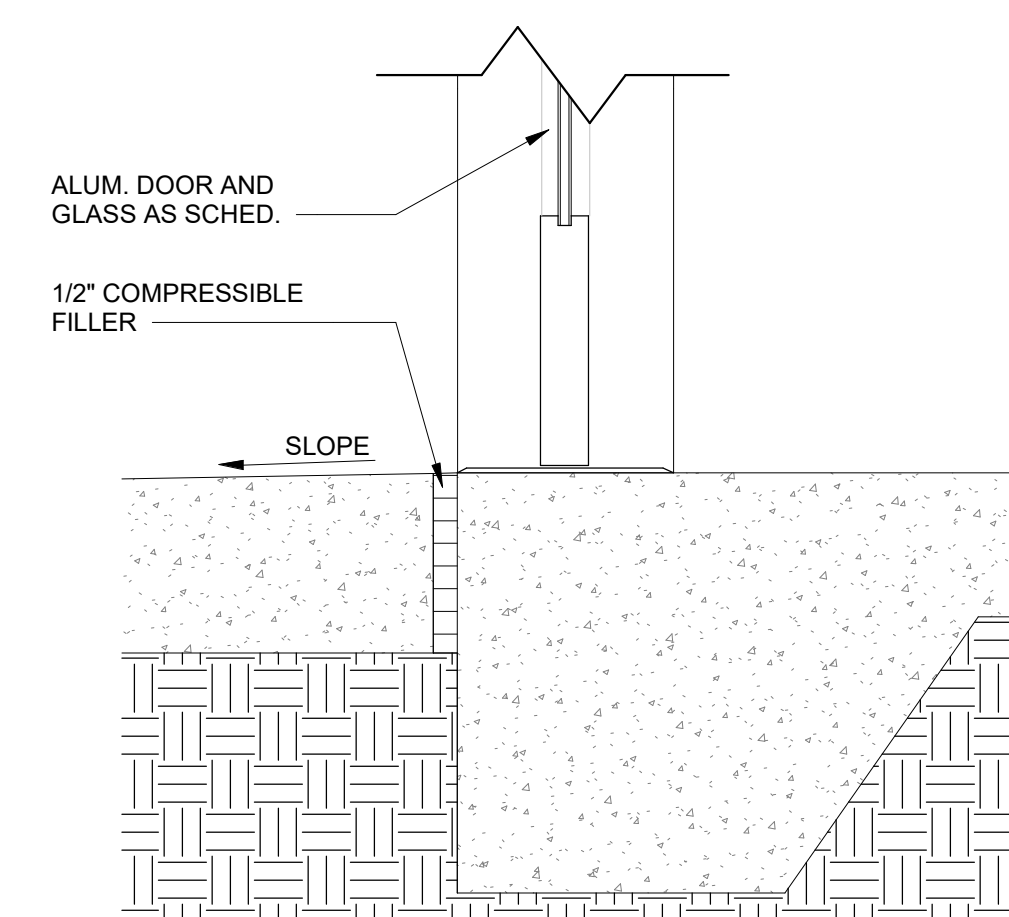

10 THRESHOLD DETAIL
A251 3" = 1'-0"

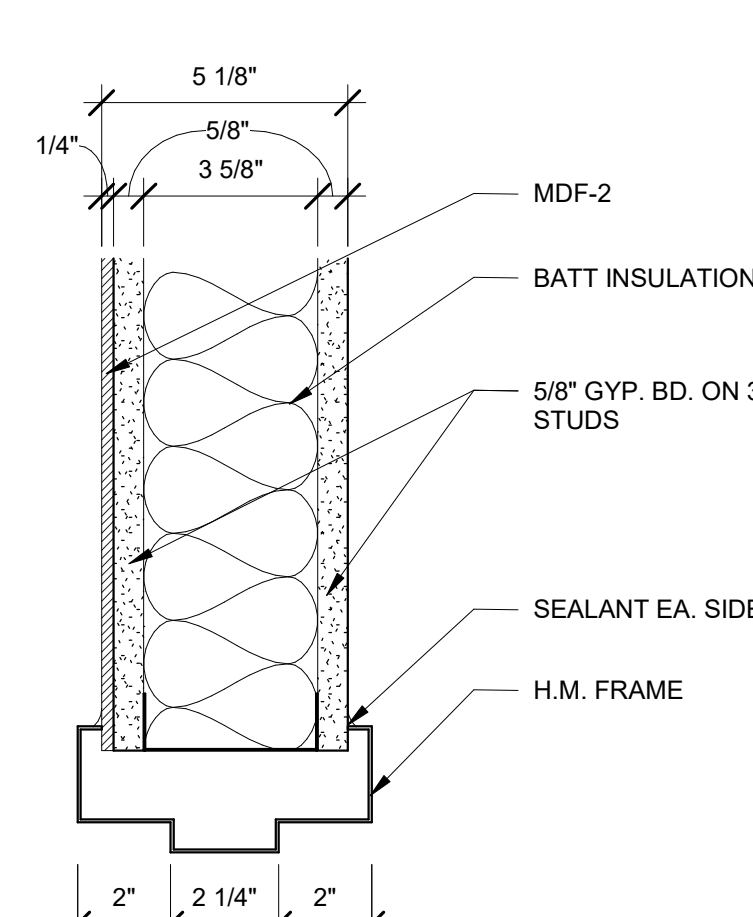

11 HEAD
A251 3" = 1'-0"

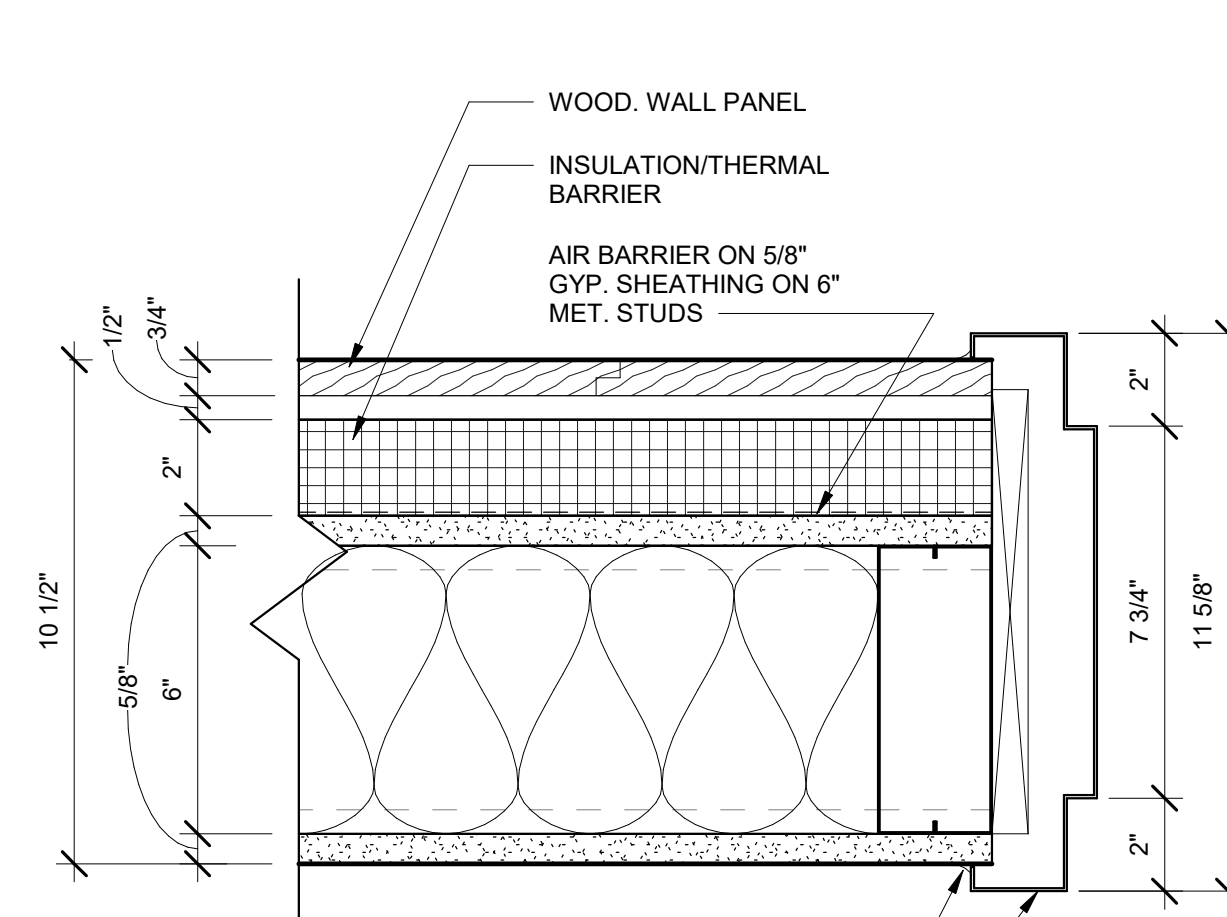

14 JAMB
A251 3" = 1'-0"

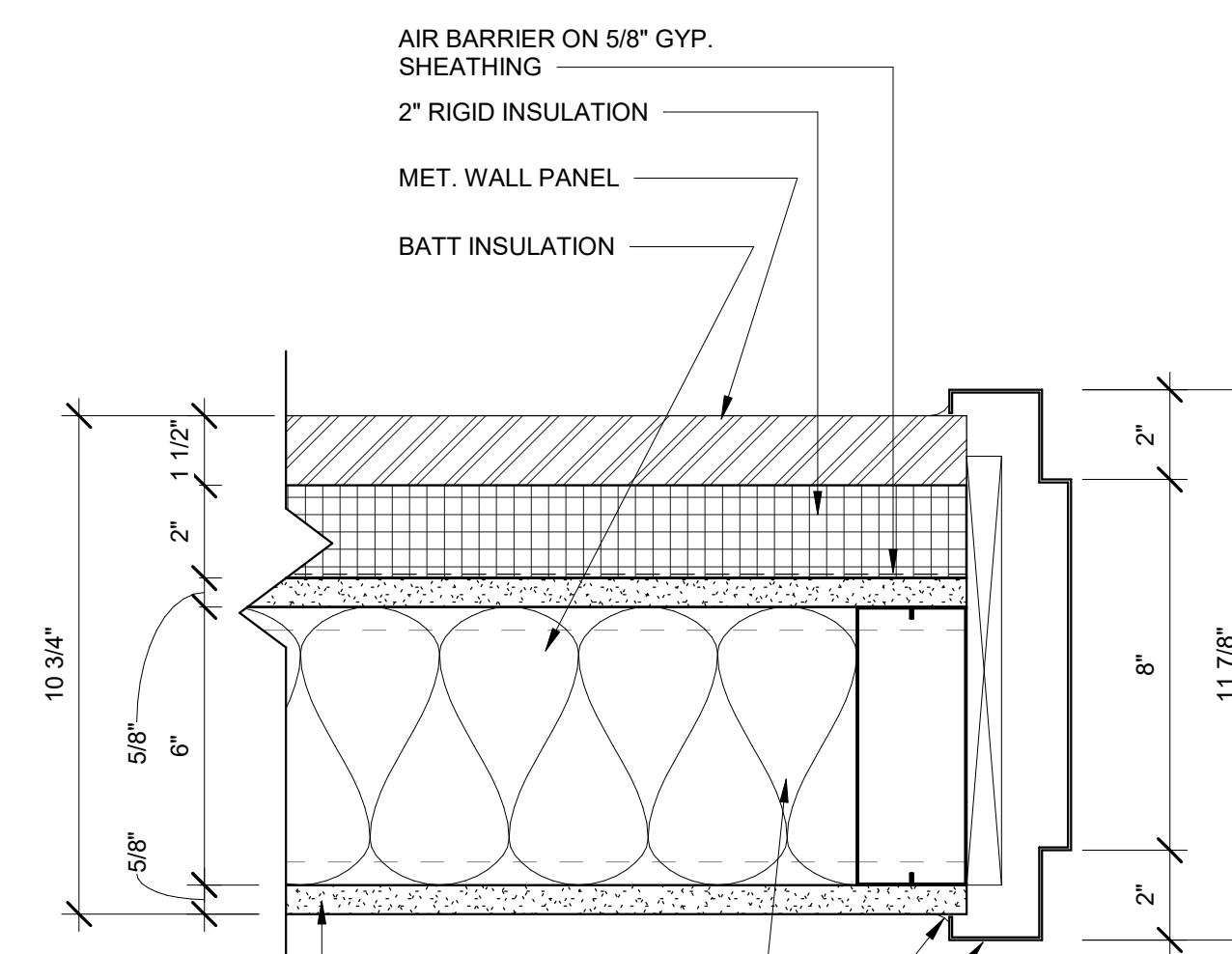

15 JAMB
A251 3" = 1'-0"

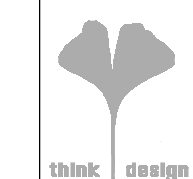

8801 JM Keynes Drive
Suite 365
Charlotte, NC 28262
704.248.2922
www.biloba.co

Civil and Structural Engineer, Landscape Architect:

Stewart Inc.
Raleigh 223 S. West Street, Suite 1100
Raleigh, NC 27603
NC Certificate of Licensure: C-1051

Plumbing, Mechanical, and Electrical Engineer:

RMF Engineering
5520 Research Park Drive, Ste 300
Baltimore, MD 21228
NC Certificate of Licensure: C-1125

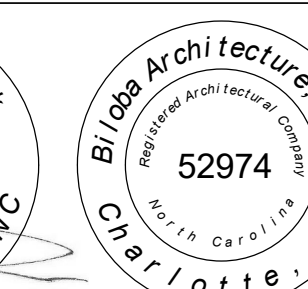

02.12.2025

Drawn ADO

Checked IWP

Date 01/10/2025

Revisions

2 02/12/2025 Addendum No. 3

Copyright 2024. All rights reserved. Printed or electronic drawings and documentation may not be reproduced in any form without written permission from Biloba Architecture, PLLC.

NCSU Apiculture Facility

Raleigh, NC

SCO ID No.: 22-24494-01A
Code: 42124 Item: 315
NCSU: 202220007

Project Number 132

Title

Door Schedule, Frame Elevations, and Details

Sheet

A251

Plate

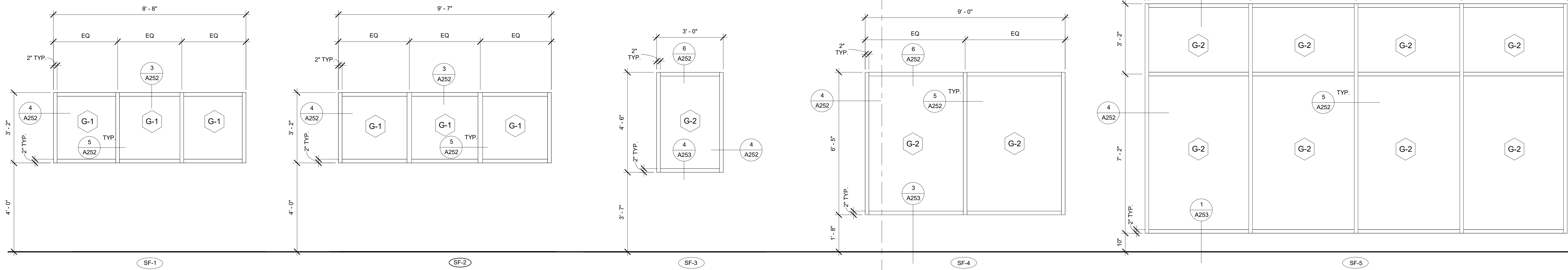

1 STOREFRONT ELEVATIONS
A252 1/2" = 1'-0"

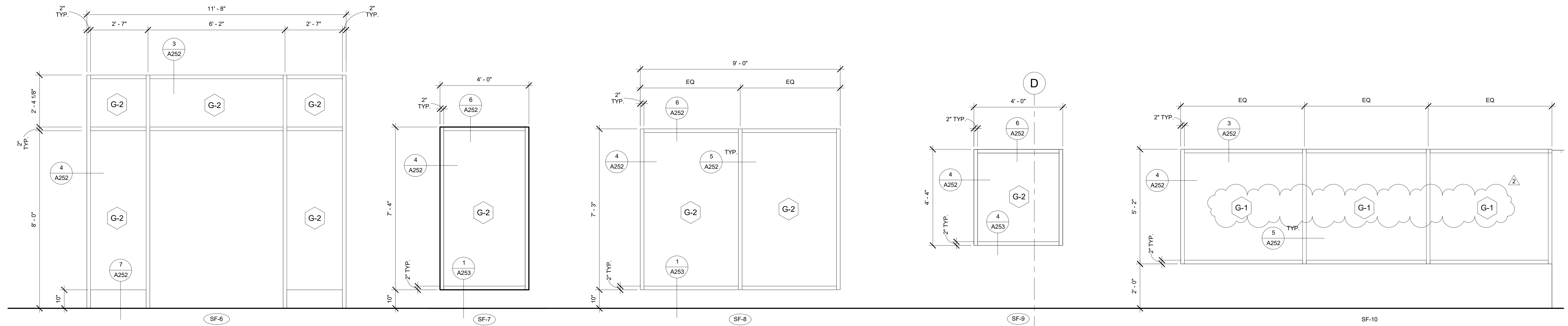

2 STOREFRONT ELEVATIONS
A252 1/2" = 1'-0"

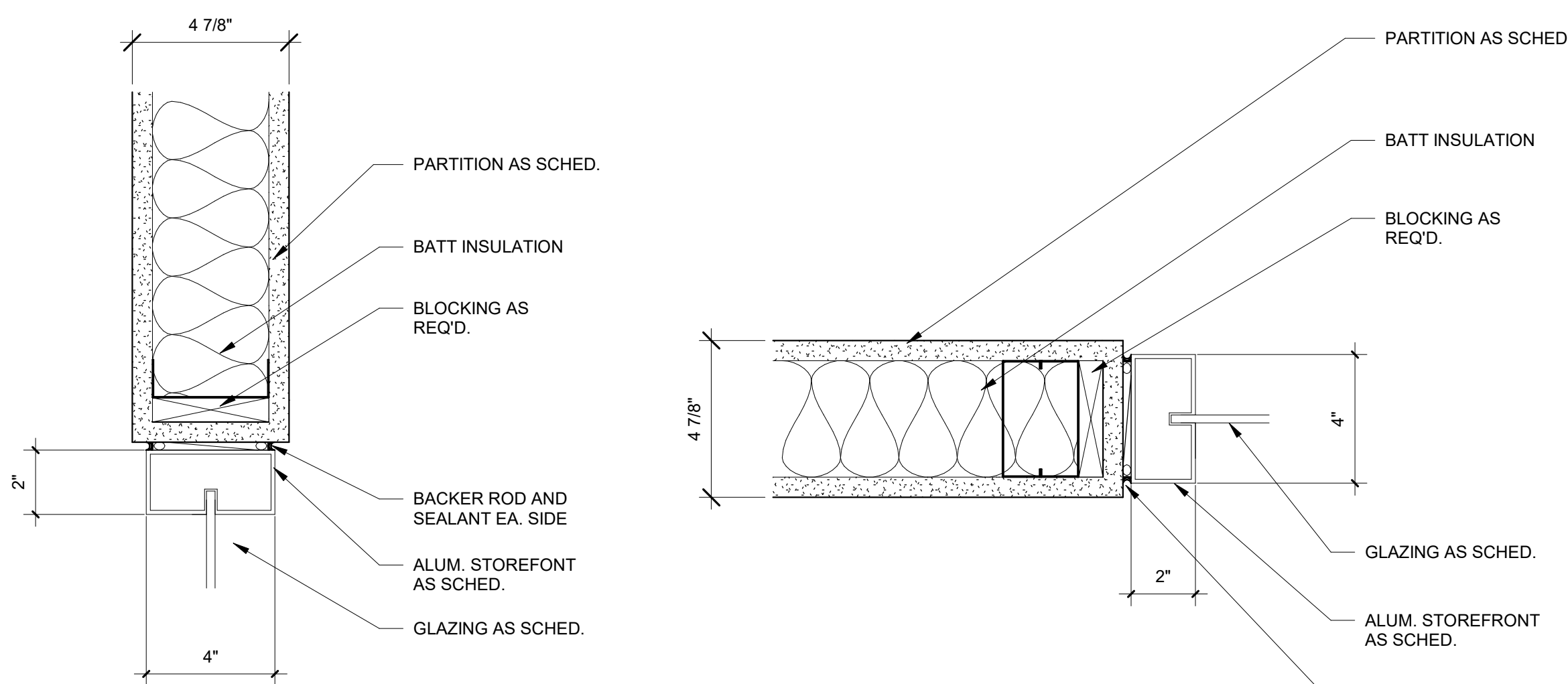

3 HEAD
A252 3" = 1'-0"

4 JAMB
A252 3" = 1'-0"

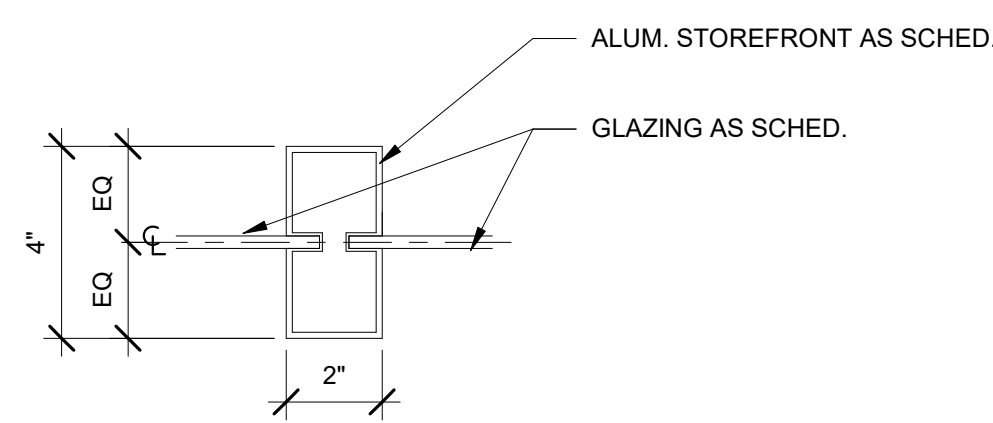

5 JAMB
A252 3" = 1'-0"

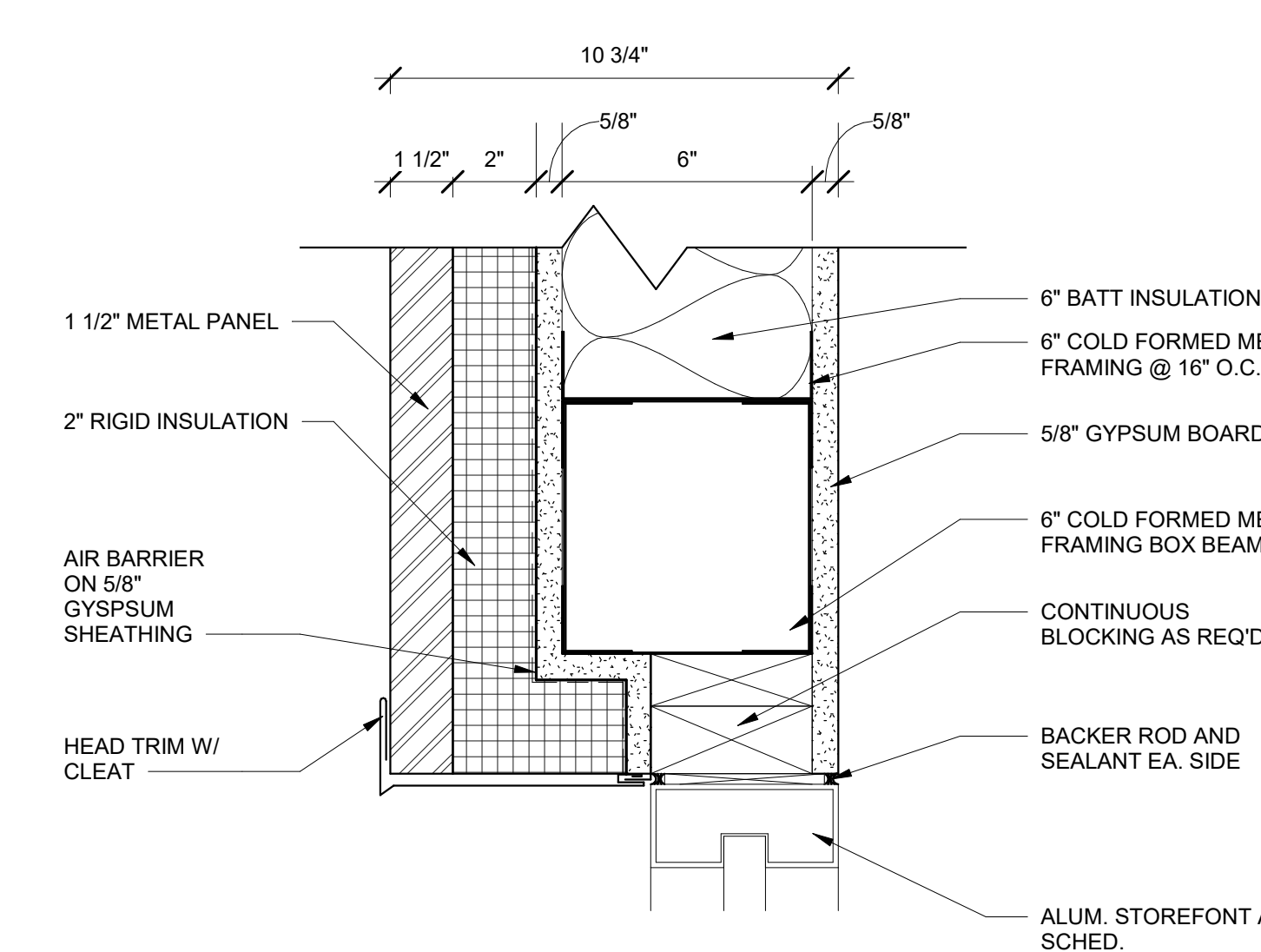

6 HEAD
A252 3" = 1'-0"

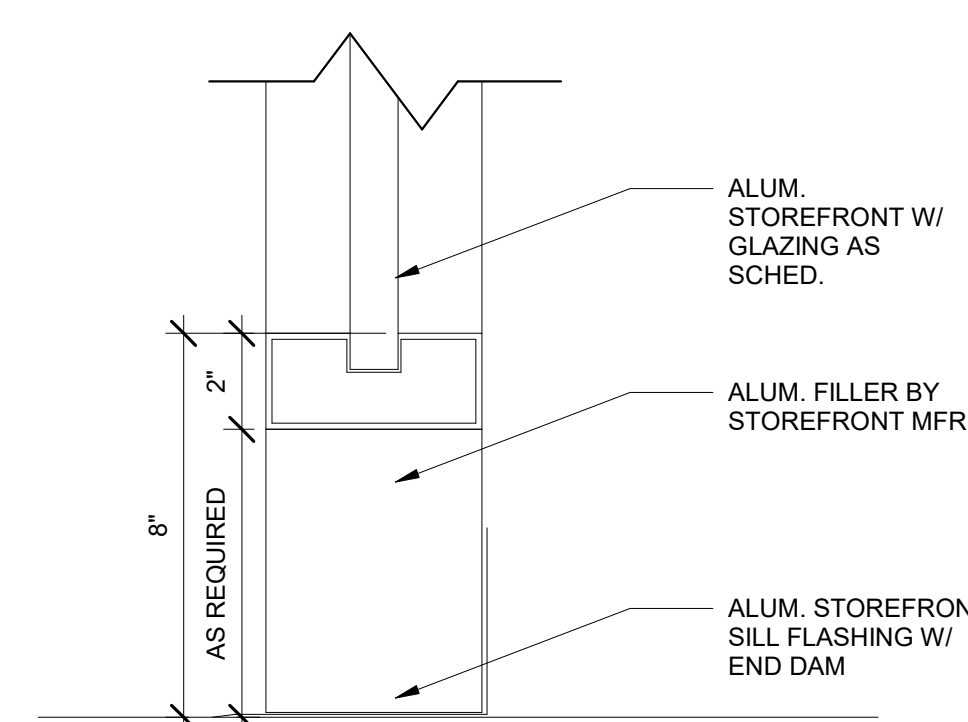

7 SILL
A252 3" = 1'-0"

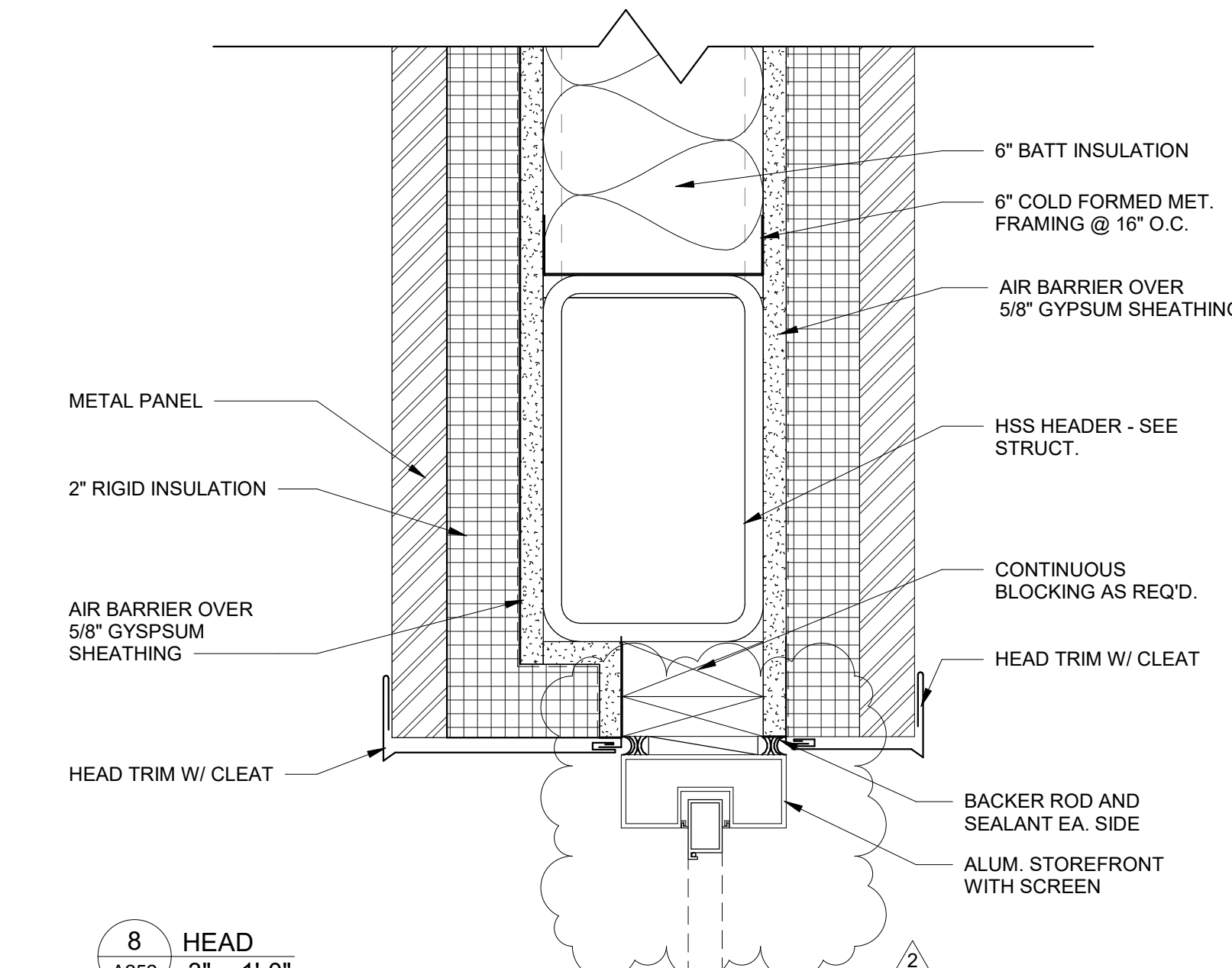

8 HEAD
A252 3" = 1'-0"

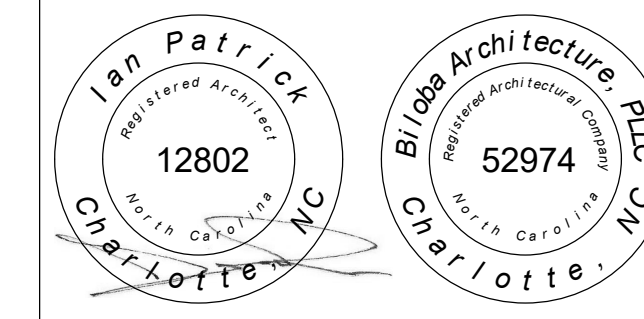

02.12.2025

Drawn	ADO
Checked	IWP
Date	01/10/2025
Revisions	
2	02/12/2025 Addendum No. 3

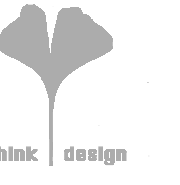

8801 JM Keynes Drive
Suite 365
Charlotte, NC 28262
704.248.2922
www.biloba.co

Civil and Structural Engineer, Landscape Architect:
Stewart Inc.
Raleigh 223 S. West Street, Suite 1100
Raleigh, NC 27603
NC Certificate of Licensure: C-1051

Plumbing, Mechanical, and Electrical Engineer:
RMP Engineering
5520 Research Park Drive, Ste 300
Baltimore, MD 21228
NC Certificate of Licensure: C-1125

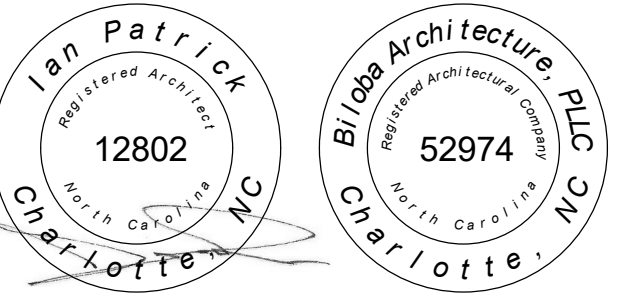

02.12.2025

Drawn	ADD
Checked	IWP
Date	01/10/2025
Revisions	
2	02/12/2025 Addendum No. 3

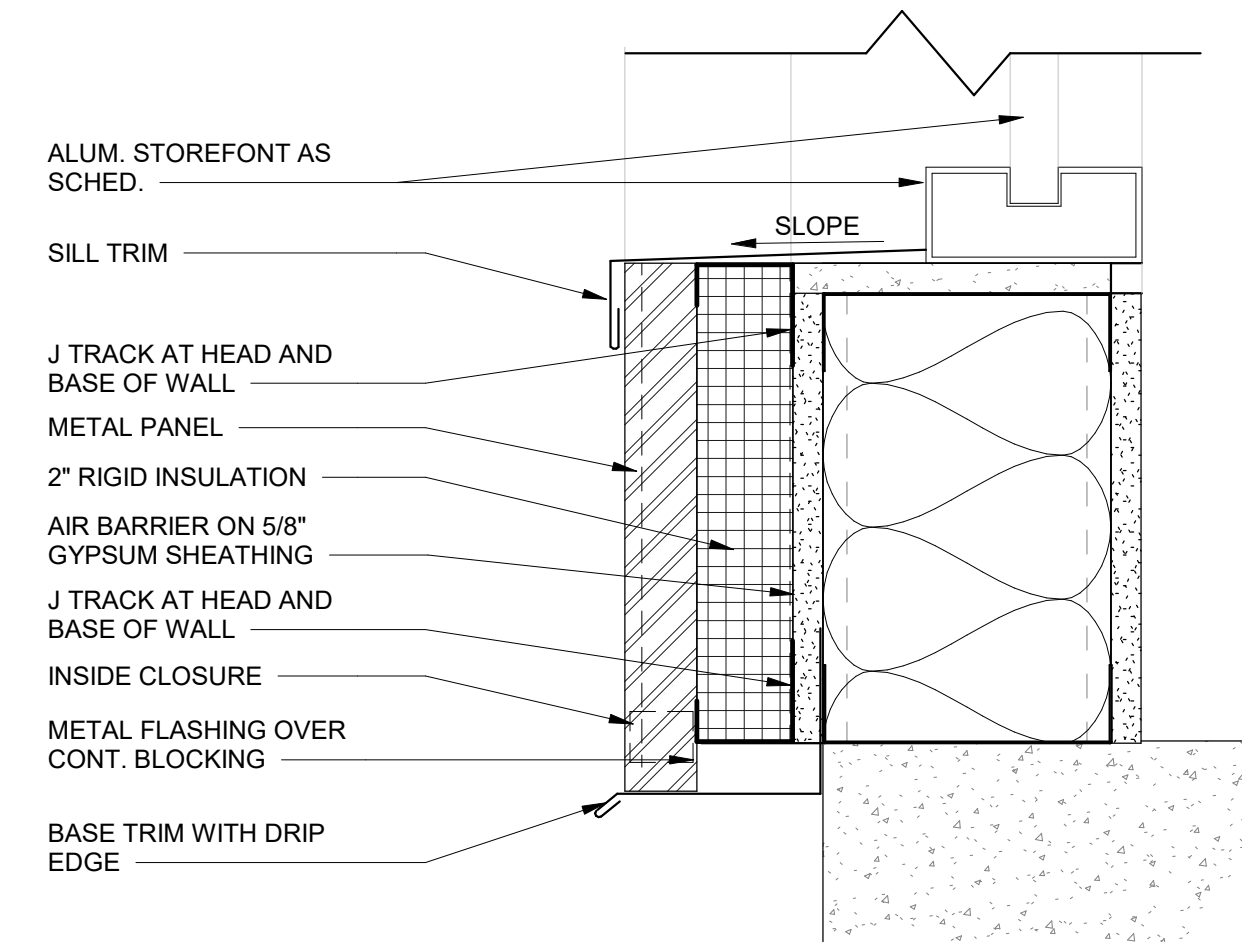

1 SILL AND WALL BASE
A253 3" = 1'-0"

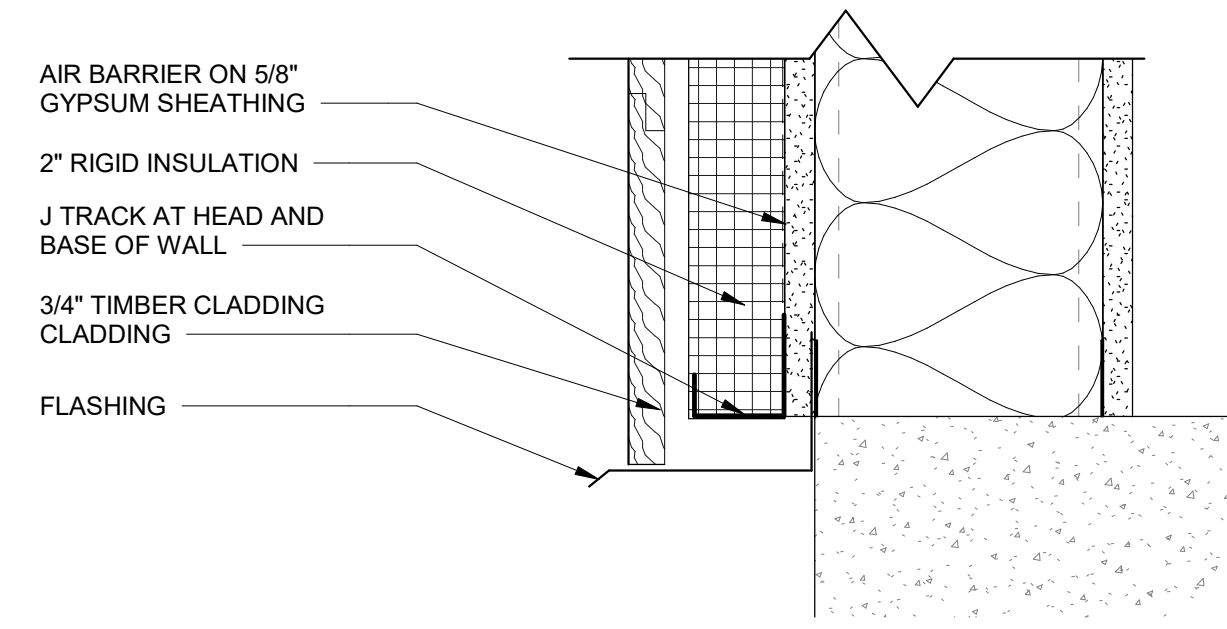

2 WALL BASE
A253 3" = 1'-0"

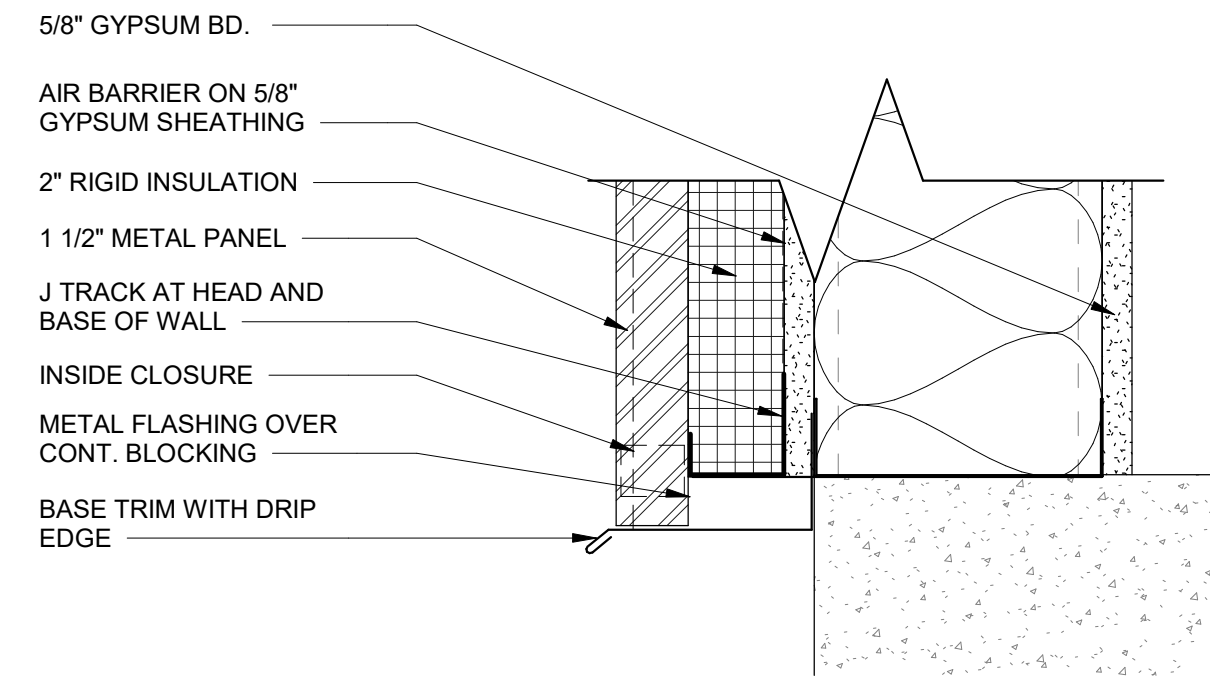

3 WALL BASE
A253 3" = 1'-0"

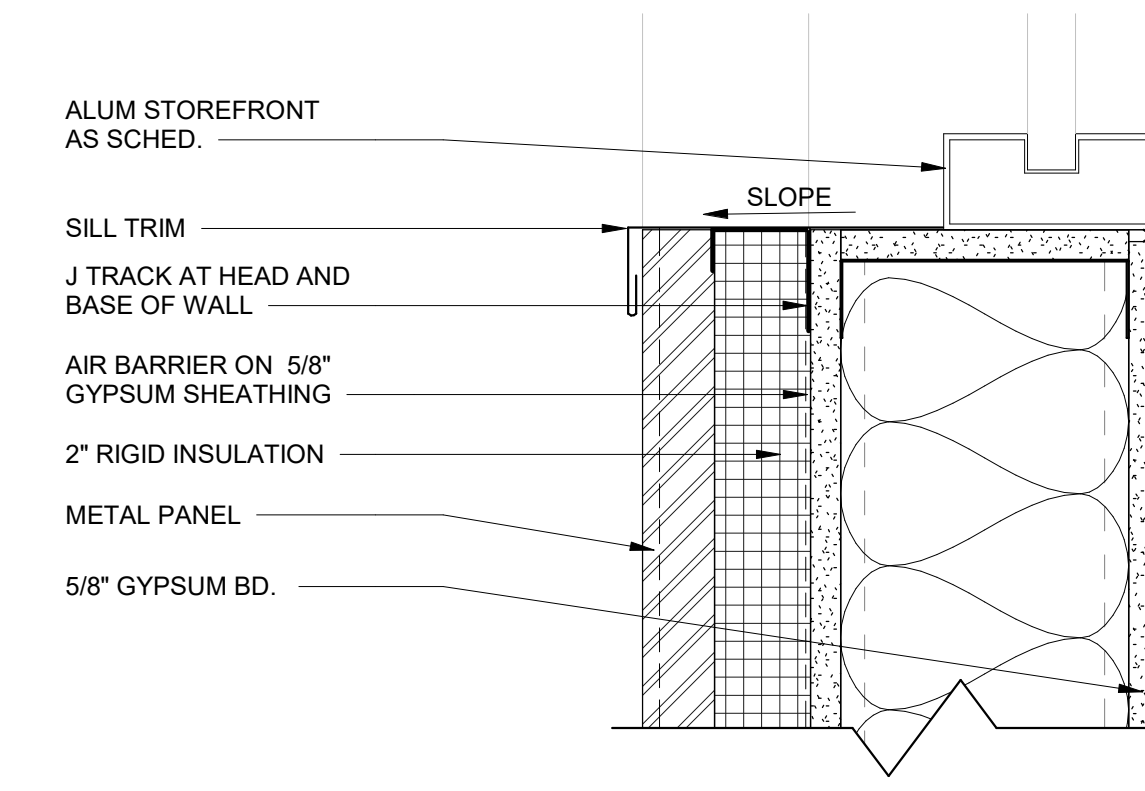

4 SILL
A253 3" = 1'-0"

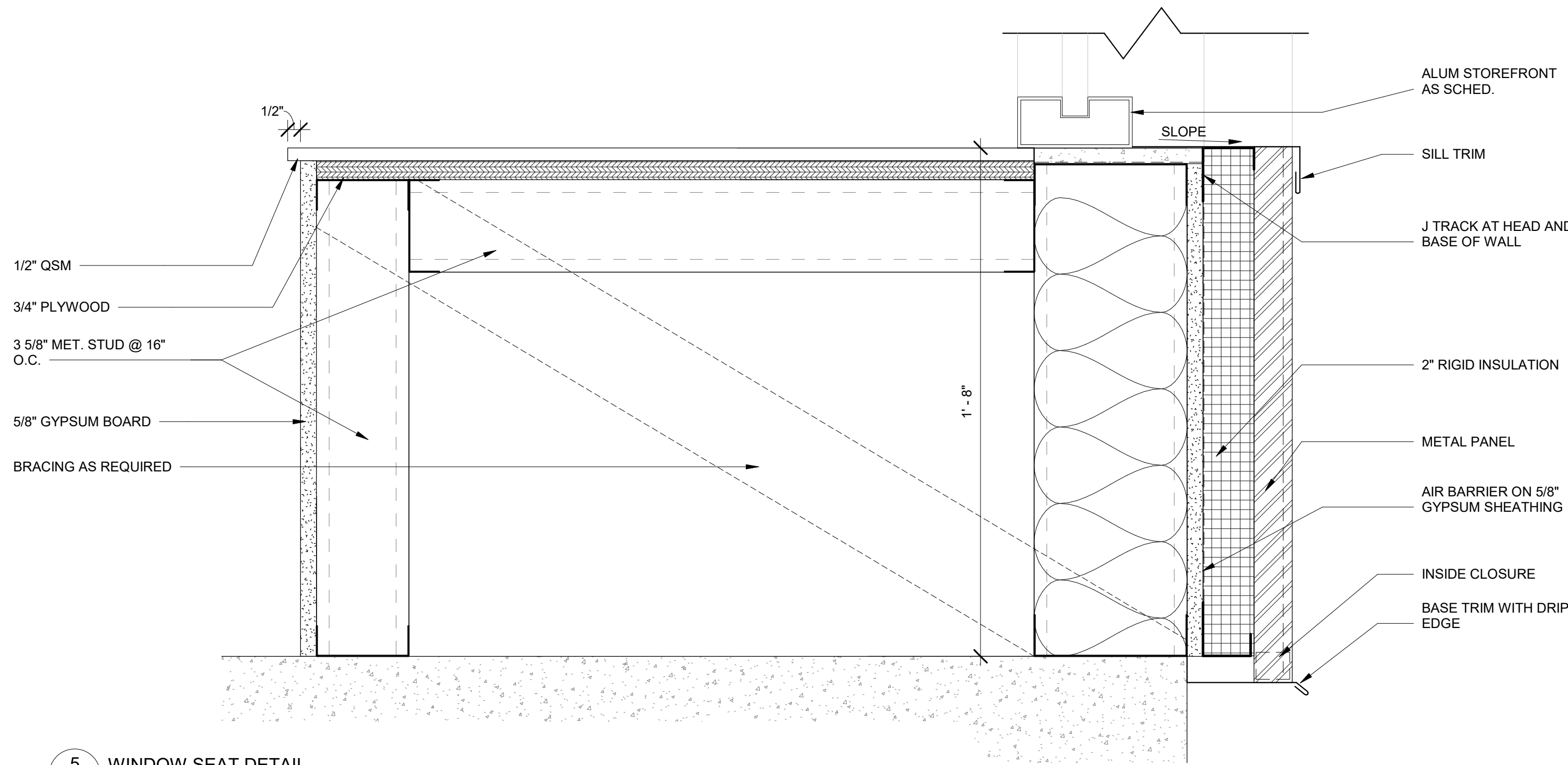

5 WINDOW SEAT DETAIL
A253 3" = 1'-0"

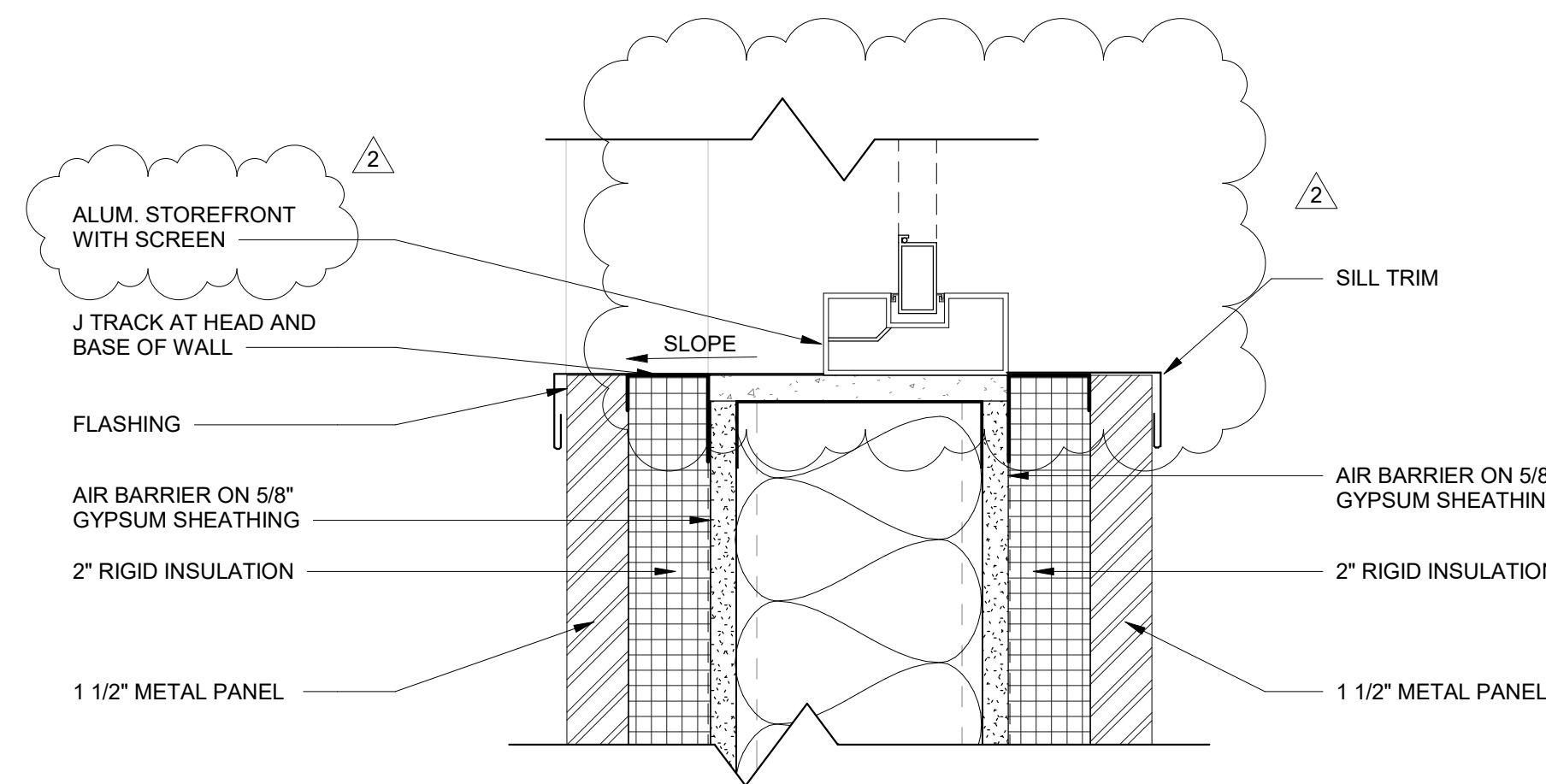

6 SILL DETAIL
A253 3" = 1'-0"

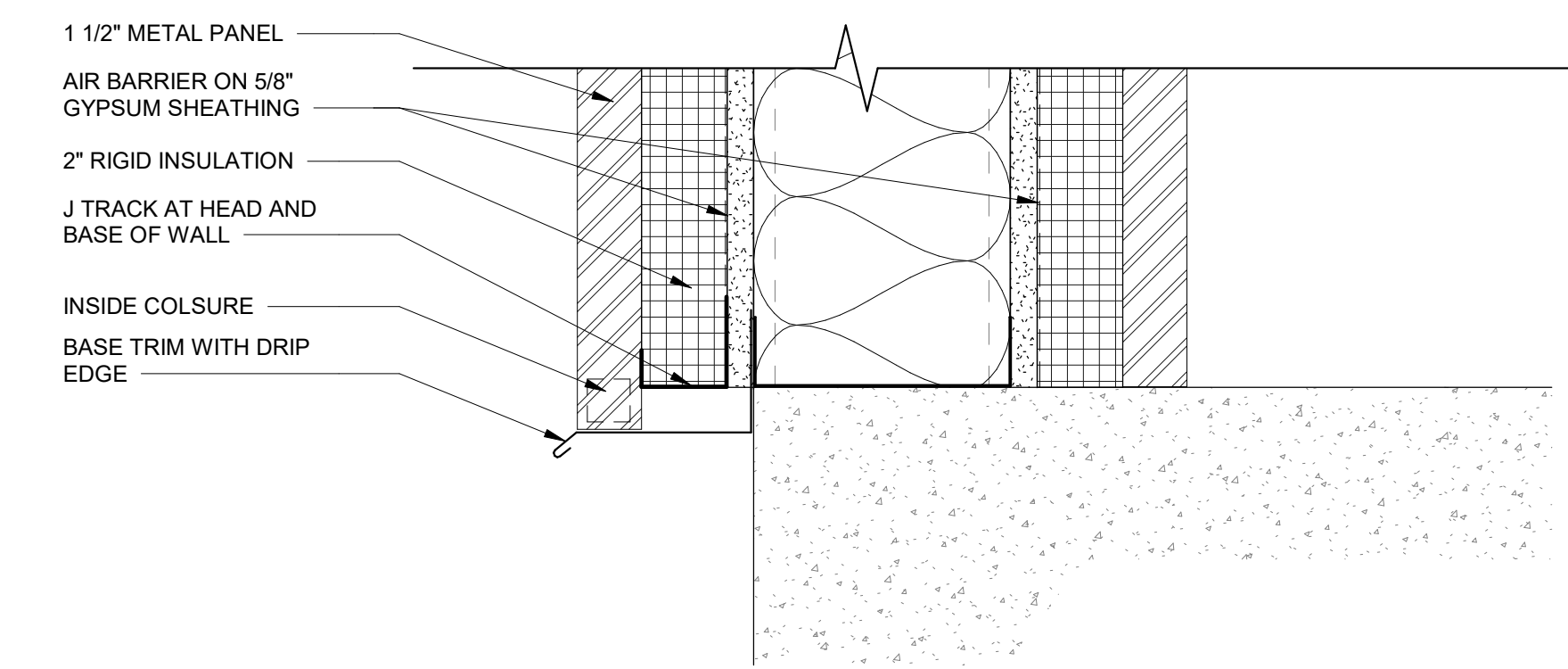

7 WALL BASE
A253 3" = 1'-0"

Copyright 2024. All rights reserved. Printed or electronic drawings and documentation may not be reproduced in any form without written permission from Biloba Architecture, PLLC.

NCSU Apiculture Facility
Raleigh, NC
SCO ID No.: 22-24494-01A
Code: 42124 Item: 315
NCSU: 20222007

Project Number 132

Title
Storefront and Window Sectional Details

Sheet

A253

Plate

2/22/2025 12:06:28 PM

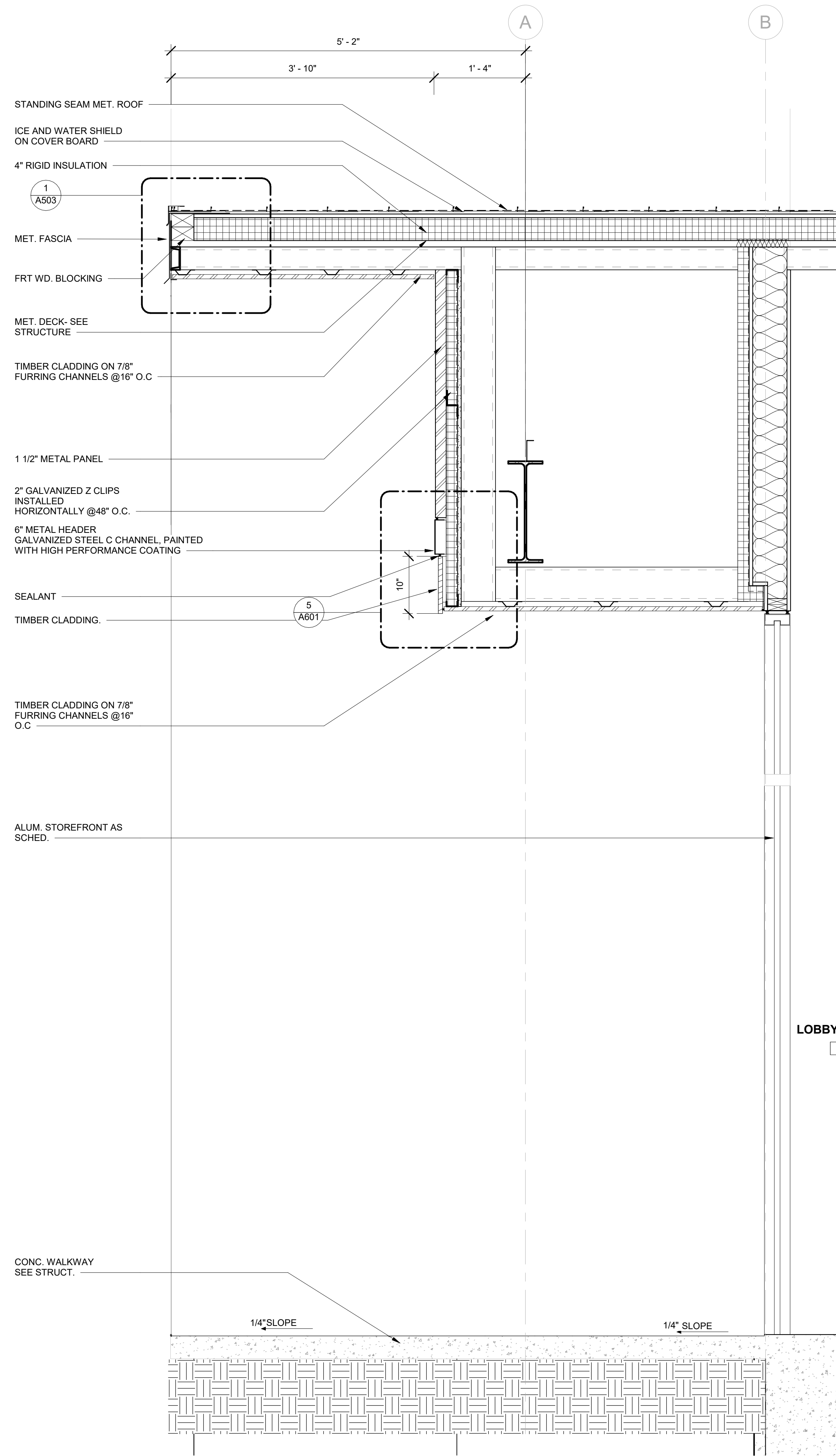

1 WALL SECTION
A404 1" = 1'-0"

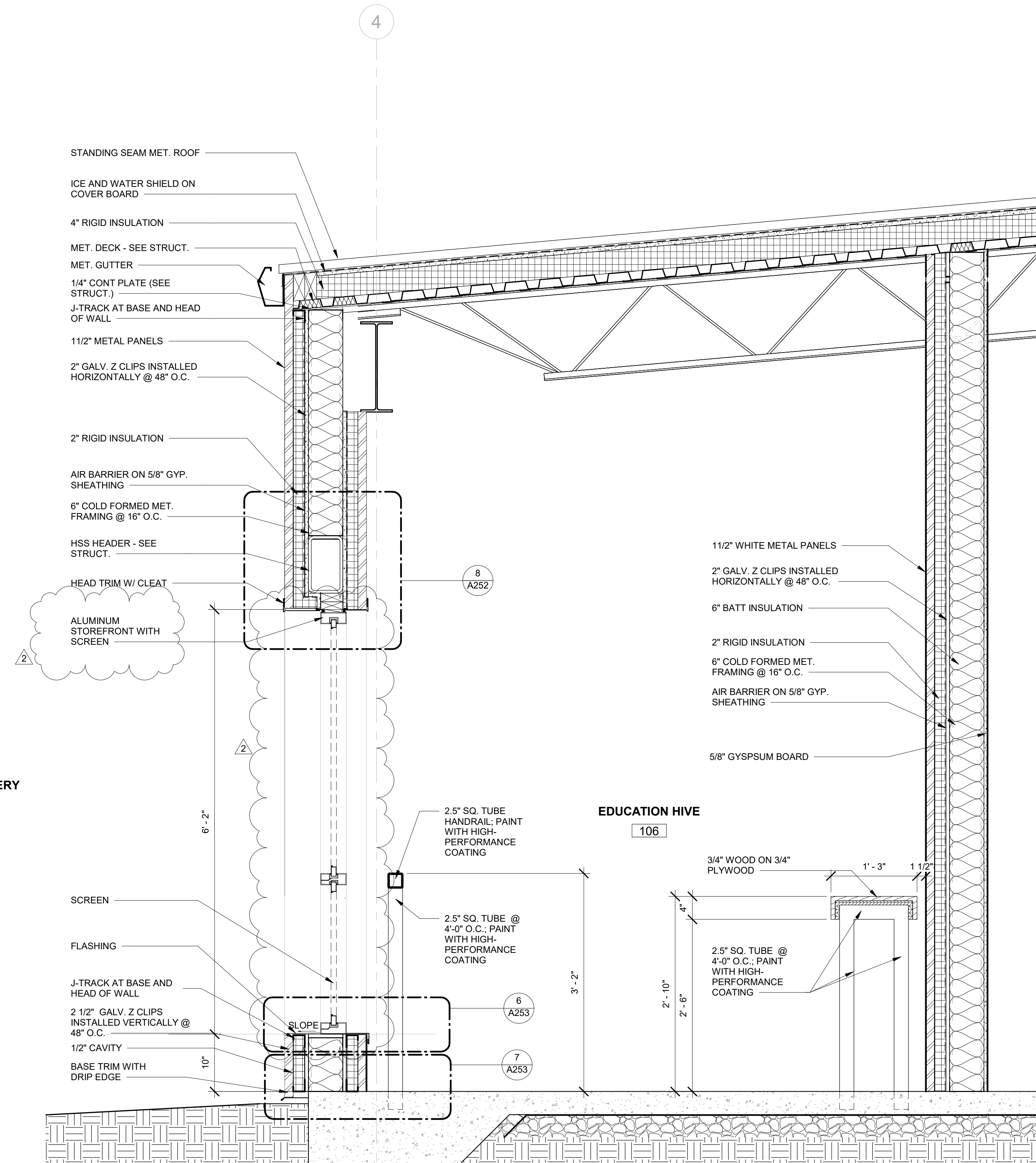

2 WALL SECTION
A404 1" = 1'-0"

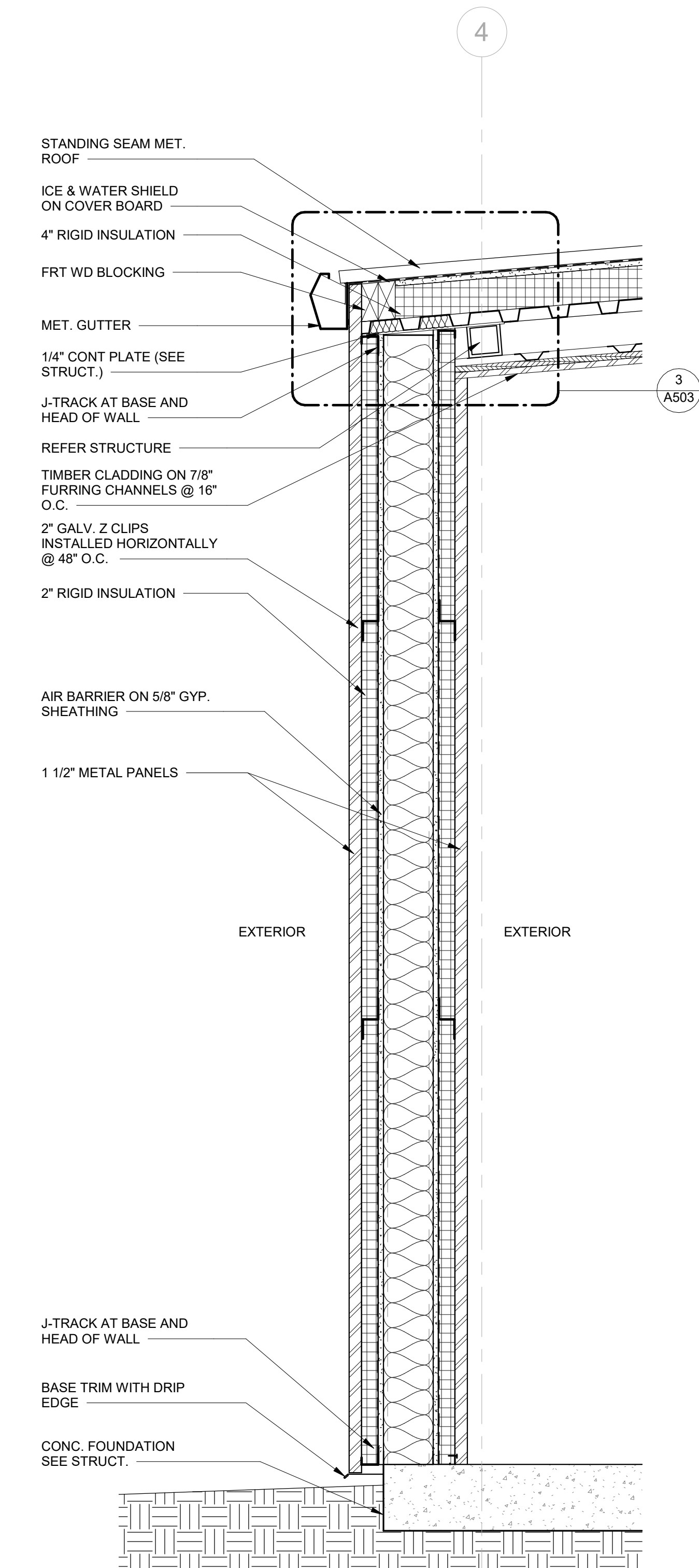

3 WALL SECTION
A404 1" = 1'-0"

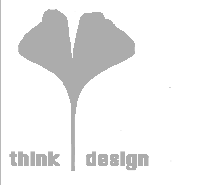

8801 JM Keynes Drive
Suite 365
Charlotte, NC 28262
704.248.2922
www.biloba.co

Civil and Structural Engineer, Landscape Architect:
Stewart Inc.
Raleigh 223 S. West Street, Suite 1100
Raleigh, NC 27603
NC Certificate of Licensure: C-1051

Plumbing, Mechanical, and Electrical Engineer:
RMP Engineering
5520 Research Park Drive, Ste 300
Baltimore, MD 21228
NC Certificate of Licensure: C-1125

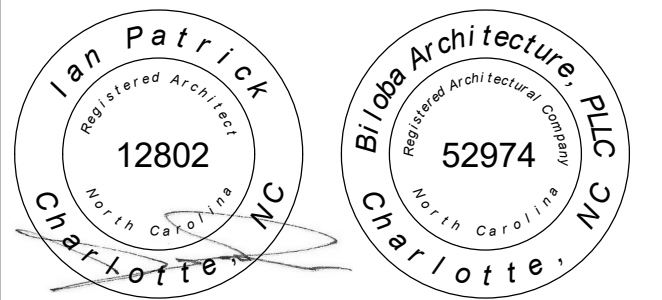

02.12.2025

Drawn KA
Checked IWP
Date 01/10/2025
Revisions
2 02/12/2025 Addendum No. 3

Copyright 2024. All rights reserved. Printed or electronic drawings and documentation may not be reproduced in any form without written permission from Biloba Architecture, PLLC.

NCSU Apiculture Facility
Raleigh, NC
SCO ID No.: 22-24494-01A
Code: 42124 Item: 315
NCSU: 202220007

Project Number 132

Title
Wall Sections

Sheet

A404

Plate

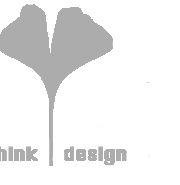

8801 JM Keynes Drive
Suite 365
Charlotte, NC 28262
704.248.2922
www.biloba.co

Civil and Structural Engineer, Landscape Architect:
Stewart Inc.
Raleigh 223 S. West Street, Suite 1100
Raleigh, NC 27603
NC Certificate of Licensure: C-1051

Plumbing, Mechanical, and Electrical Engineer:
RMF Engineering
5520 Research Park Drive, Ste 300
Baltimore, MD 21228
NC Certificate of Licensure: C-1125

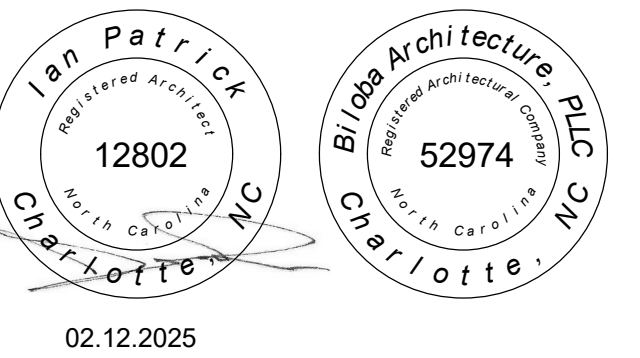

Drawn	Author
Checked	Checker
Date	01/10/2025
Revisions	
2	02/12/2025 Addendum No. 3

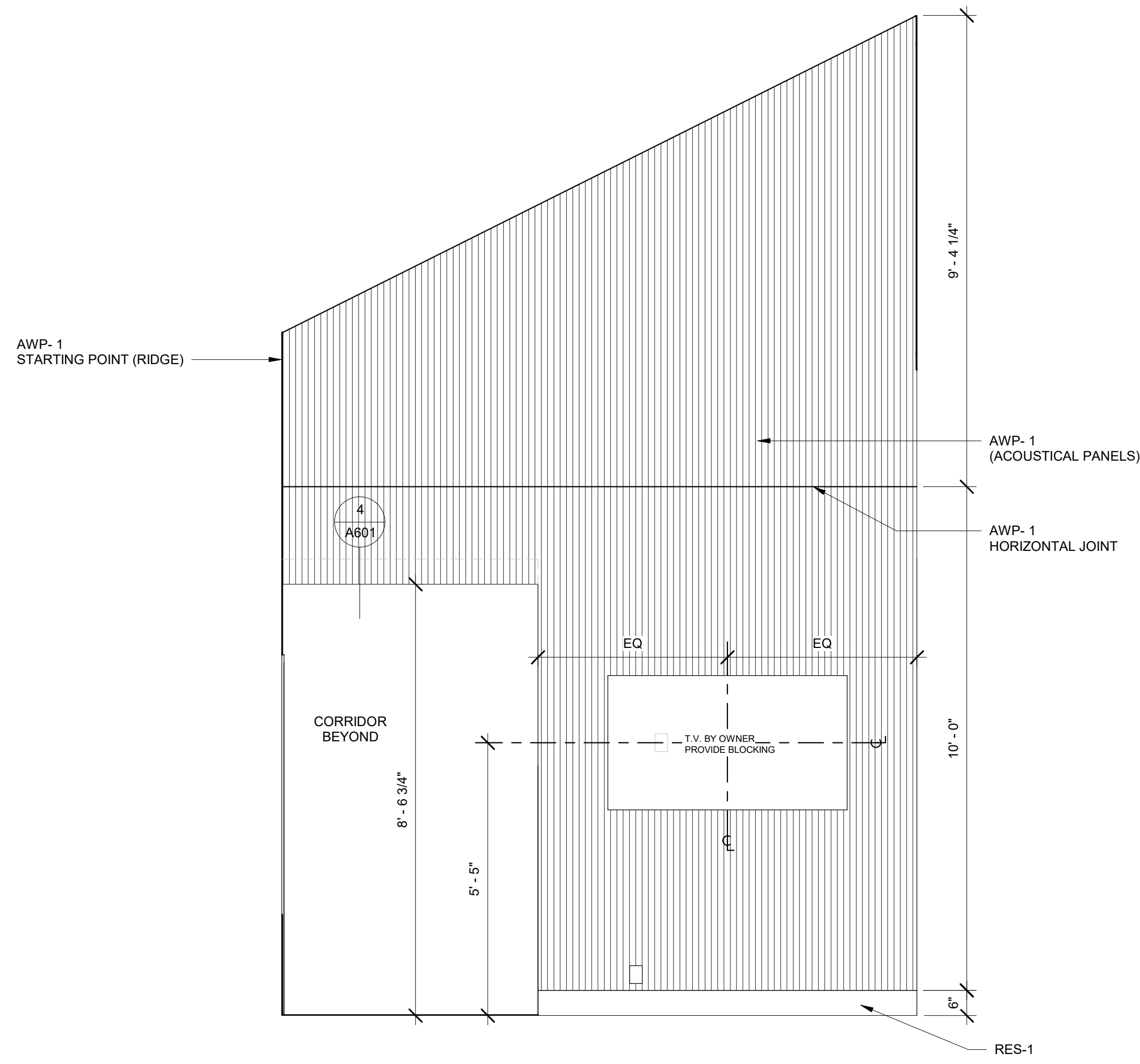

2 ELEVATION
A705 1/2" = 1'-0"

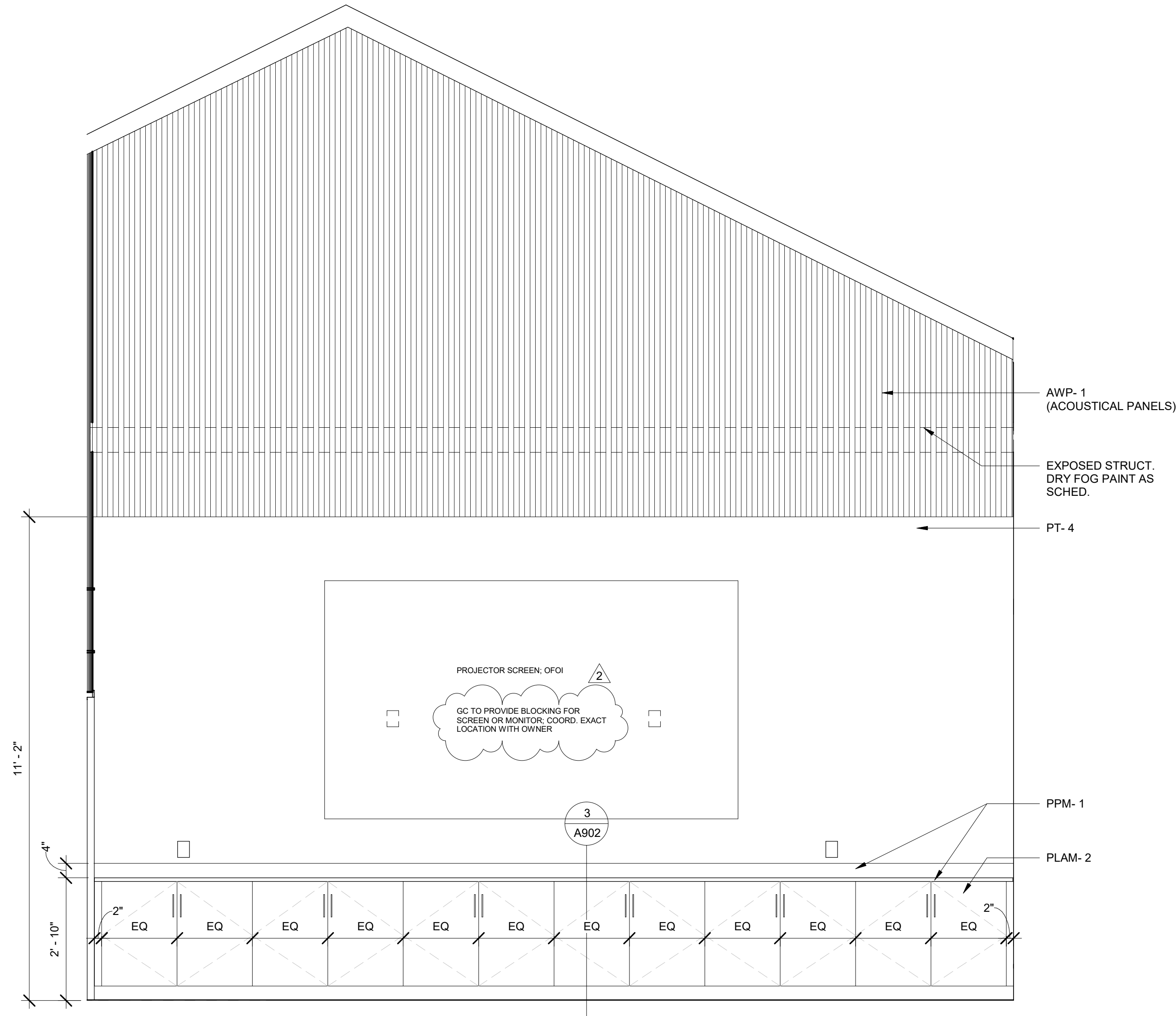

1 ELEVATION
A705 1/2" = 1'-0"

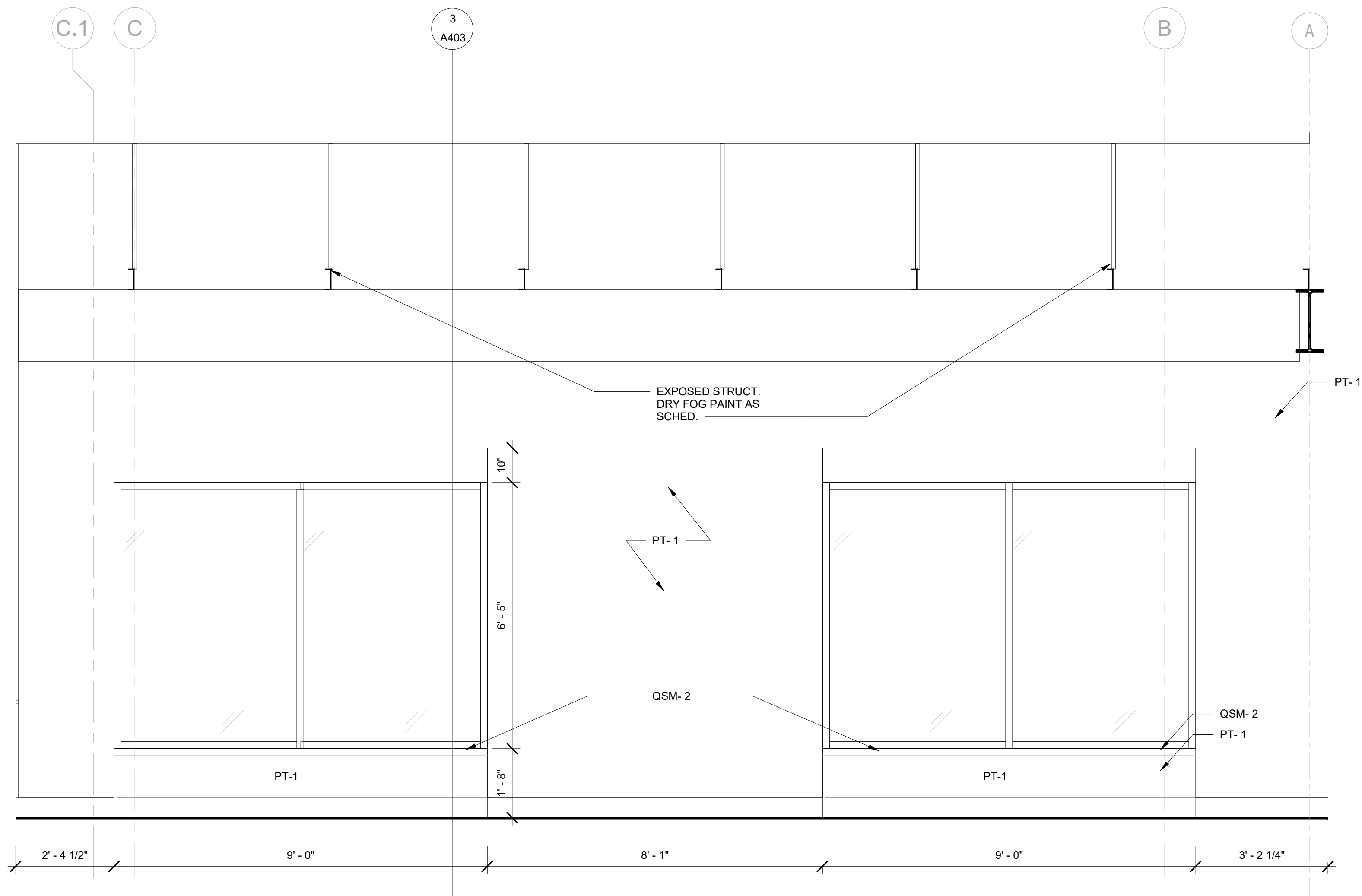

3 ELEVATION
A705 1/2" = 1'-0"

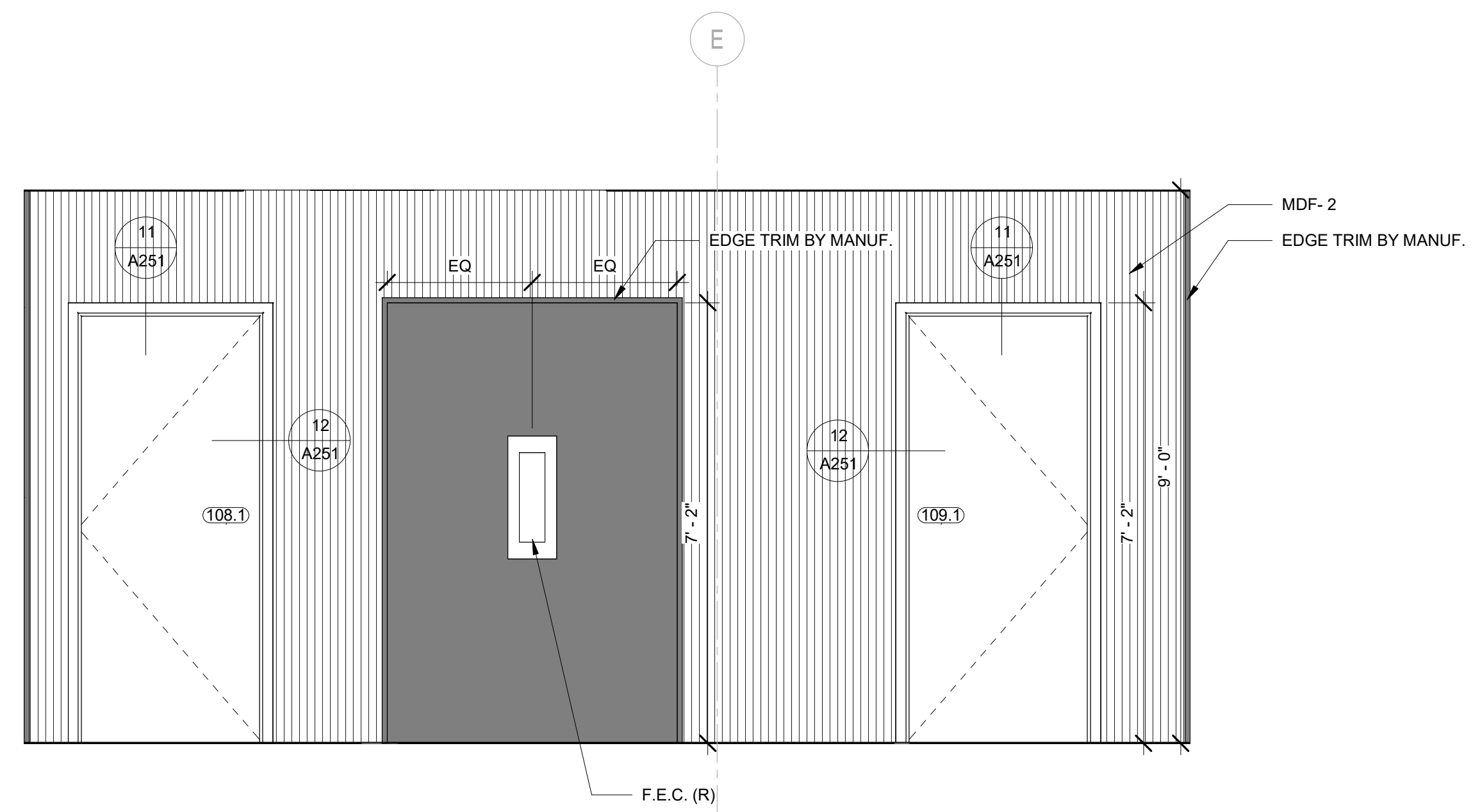

4 ELEVATION
A705 1/2" = 1'-0"

Copyright 2024. All rights reserved. Printed or electronic drawings and documentation may not be reproduced in any form without written permission from Biloba Architecture, PLLC.

NCSU Apiculture Facility
Raleigh, NC
SCO ID No.: 22-24494-01A
Code: 42124 Item: 315
NCSU: 20222007

Project Number 132

Title
Interior Elevations and Details

Sheet

A705

Plate

FORM OF PROPOSAL

Apiculture Facility

Contract: _____

North Carolina State University

Bidder: _____

SCO-ID # 22-24494-01A

Date: _____

The undersigned, as bidder, hereby declares that the only person or persons interested in this proposal as principal or principals is or are named herein and that no other person than herein mentioned has any interest in this proposal or in the contract to be entered into; that this proposal is made without connection with any other person, company or parties making a bid or proposal; and that it is in all respects fair and in good faith without collusion or fraud. The bidder further declares that he has examined the site of the work and the contract documents relative thereto, and has read all special provisions furnished prior to the opening of bids; that he has satisfied himself relative to the work to be performed. The bidder further declares that he and his subcontractors have fully complied with NCGS 64, Article 2 in regards to E-Verification as required by Section 2.(c) of Session Law 2013-418, codified as N.C. Gen. Stat. § 143-129(j).

The Bidder proposes and agrees if this proposal is accepted to contract with the

State of North Carolina through North Carolina State University

in the form of contract specified below, to furnish all necessary materials, equipment, machinery, tools, apparatus, means of transportation and labor necessary to complete the construction of

Apiculture Facility

in full in complete accordance with the plans, specifications and contract documents, to the full and entire satisfaction of the State of North Carolina, and

North Carolina State University and Biloba Architecture, PLLC

with a definite understanding that no money will be allowed for extra work except as set forth in the General Conditions and the contract documents, for the sum of:

SINGLE PRIME CONTRACT:

Base Bid:

_____ Dollars(\$)

General Subcontractor:

Plumbing Subcontractor:

_____ Lic _____

_____ Lic _____

Mechanical Subcontractor:

Electrical Subcontractor:

_____ Lic _____

_____ Lic _____

GS143-128(d) requires all single prime bidders to identify their subcontractors for the above subdivisions of work. A contractor whose bid is accepted shall not substitute any person as subcontractor in the place of the subcontractor listed in the original bid, except (i) if the listed subcontractor's bid is later determined by the contractor to be non-responsible or non-responsive or the listed subcontractor refuses to enter into a contract for the complete performance of the bid work, or (ii) with the approval of the awarding authority for good cause shown by the contractor.

ALTERNATES:

Should any of the alternates as described in the contract documents be accepted, the amount written below shall be the amount to be "added to" or "deducted from" the base bid. (Strike out "Add" or "Deduct" as appropriate.)

GENERAL CONTRACT:

Alternate No. 1 Owner-Preferred Door Hardware

<u>(Add) (Deduct)</u>		Dollars(\$)
<u>Alternate No. 1B</u>	Owner-Preferred Controller	
<u>(Add) (Deduct)</u>		Dollars(\$)
<u>Alternate No. 1C</u>	Owner-Preferred Controls	
<u>(Add) (Deduct)</u>		Dollars(\$)
<u>Alternate No. 1D</u>	Owner-Preferred Controls	
<u>(Add) (Deduct)</u>		Dollars(\$)
<u>Alternate No. 2</u>	Barnquilt Custom Panels	
<u>(Add) (Deduct)</u>		Dollars(\$)
<u>Alternate No. 3</u>	Moveable Glass Wall	
<u>(Add) (Deduct)</u>		Dollars(\$)
<u>Alternate No. 4</u>	Ceramic Wall Tile	
<u>(Add) (Deduct)</u>		Dollars(\$)
<u>Alternate No. 5</u>	Toilet Room 107C	
<u>(Add) (Deduct)</u>		Dollars(\$)
<u>Alternate No. 6</u>	Emergency Generator	
<u>(Add) (Deduct)</u>		Dollars(\$)
<u>Alternate No. 7</u>	Polished Concrete	
<u>(Add) (Deduct)</u>		Dollars(\$)
<u>Alternate No. 8</u>	FRP and PVC Roll Flooring	
<u>(Add) (Deduct)</u>		Dollars(\$)
<u>Alternate No. 9</u>	AHU Screening	
<u>(Add) (Deduct)</u>		Dollars(\$)
<u>Alternate No. 10</u>	Existing House and Septic Demolition	
<u>(Add) (Deduct)</u>		Dollars(\$)
<u>Alternate No. 11</u>	Laboratory Casework	
<u>(Add) (Deduct)</u>		Dollars(\$)

UNIT PRICES

Unit prices quoted and accepted shall apply throughout the life of the contract, except as otherwise specifically noted. Unit prices shall be applied, as appropriate, to compute the total value of changes in the base bid quantity of the work all in accordance with the contract documents.

GENERAL CONTRACT:

No. 1 Removal and replacement of unsuitable Soils one cubic yard Unit Price (\$) _____

*No. 2 Placement of #57 stone one ton Unit Price (\$) _____

*No. 3 Placement of fill soil one cubic yard Unit Price (\$) _____

The bidder further proposes and agrees hereby to commence work under this contract on a date to be specified in a written order of the designer and shall fully complete all work thereunder within the time specified in the Supplementary General Conditions Article 23. Applicable liquidated damages amount is also stated in the Supplementary General Conditions Article 23.

MINORITY BUSINESS PARTICIPATION REQUIREMENTS

Provide with the bid - Under GS 143-128.2(c) the undersigned bidder shall identify **on its bid** (Identification of Minority Business Participation Form) the minority businesses that it will use on the project with the total dollar value of the bids that will be performed by the minority businesses. **Also** list the good faith efforts (Affidavit **A**) made to solicit minority participation in the bid effort.

NOTE: A contractor that performs all of the work with its own workforce may submit an Affidavit (**B**) to that effect in lieu of Affidavit (**A**) required above. The MB Participation Form must still be submitted even if there is zero participation.

After the bid opening - The Owner will consider all bids and alternates and determine the lowest responsible, responsive bidder. Upon notification of being the apparent low bidder, the bidder shall then file within 72 hours of the notification of being the apparent lowest bidder, the following:

An Affidavit (**C**) that includes a description of the portion of work to be executed by minority businesses, expressed as a percentage of the total contract price, which is equal to or more than the 10% goal established. This affidavit shall give rise to the presumption that the bidder has made the required good faith effort and Affidavit **D** is not necessary;

* **OR** *

If less than the 10% goal, Affidavit (**D**) of its good faith effort to meet the goal shall be provided. The document must include evidence of all good faith efforts that were implemented, including any advertisements, solicitations and other specific actions demonstrating recruitment and selection of minority businesses for participation in the contract.

Note: Bidders must always submit **with their bid** the Identification of Minority Business Participation Form listing all MB contractors, vendors and suppliers that will be used. If there is no MB participation, then enter none or zero on the form. Affidavit **A** or Affidavit **B**, as applicable, also must be submitted with the bid. Failure to file a required affidavit or documentation with the bid or after being notified apparent low bidder is grounds for rejection of the bid.

Proposal Signature Page

The undersigned further agrees that in the case of failure on his part to execute the said contract and the bonds within ten (10) consecutive calendar days after being given written notice of the award of contract, the certified check, cash or bid bond accompanying this bid shall be paid into the funds of the owner's account set aside for the project, as liquidated damages for such failure; otherwise the certified check, cash or bid bond accompanying this proposal shall be returned to the undersigned.

Respectfully submitted this day of _____

(Name of firm or corporation making bid)

WITNESS:

(Proprietorship or Partnership)

By: _____
Signature

Name: _____
Print or type

Title _____
(Owner/Partner/Pres./V.Pres)

Address _____

ATTEST:

By: _____

Title: _____
(Corp. Sec. or Asst. Sec. only)

License No. _____

Federal I.D. No. _____

Email Address: _____

(CORPORATE SEAL)

Addendum received and used in computing bid:

Addendum No. 1 _____ Addendum No. 3 _____ Addendum No. 5 _____ Addendum No. 6 _____

Addendum No. 2 _____ Addendum No. 4 _____ Addendum No. 6 _____ Addendum No. 7 _____